

# PHILIPS

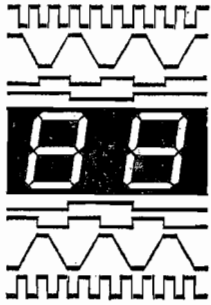

**Counter timer 80 MHz PM 6622**  
9446 066 220.1

**Timer counter 520 MHz PM 6624**  
9446 066 240.1

**Timer counter 1 GHz PM 6625**  
9446 066 250.1



# PHILIPS

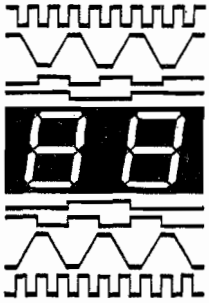

## PM 6620 Series of Counters

Ordering number of this manual 9499 460 09302

780315/3



## Contents

Performance check	29
Oscillator PM 9677	33
Oscillator PM 9678	34
Oven oscillators	35
Power supply	36
Input amplifiers	39
Logic circuits	41
Spare parts	45
Diagrams	48

# PHILIPS

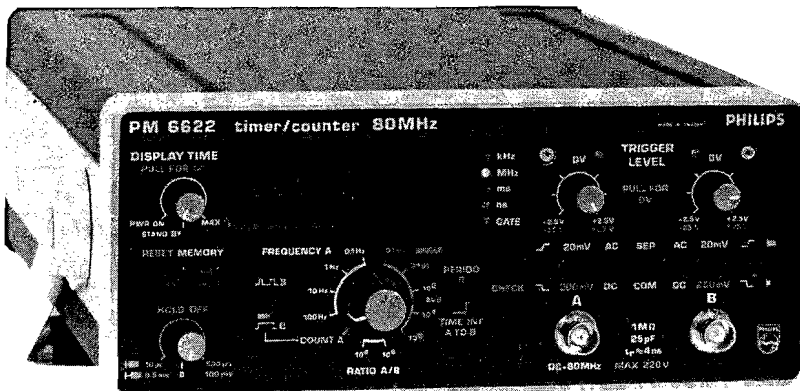

## PM 6622

9446 066 220.1

Operating manual

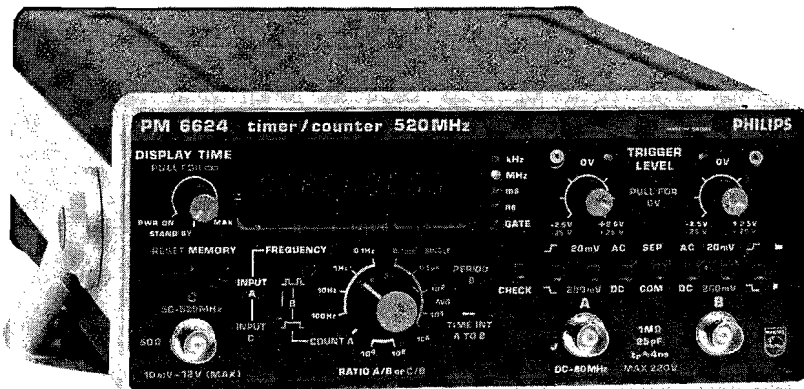

## PM 6624

9446 066 240.1

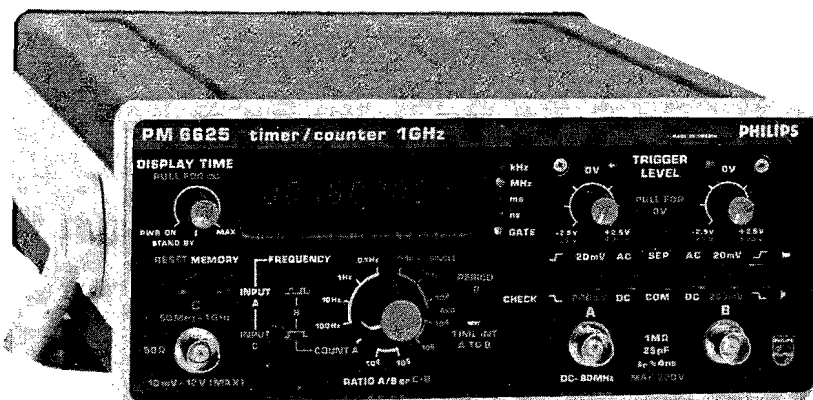

## PM 6625

9446 066 250.1



**IMPORTANT**

In correspondence concerning this instrument, please quote the type number and the serial number as given on the type plate on the rear of the instrument.

## CONTENTS

### General information

I.	Introduction	5
II.	Technical data	5
III.	Accessories	8

### Directions for use

IV.	Installation	9
	1. Mains voltage conversion	9
	2. Earthing	9
	3. Fuses	9
	4. Optional accessories	9
V.	Controls, connectors and indicators	10
VI.	Operation	16

### General information

1.	Switch on power	16
2.	Warm up time	16
3.	External frequency standard	16
4.	Control settings	16
4.1.	A, B and C inputs	16
4.2.	AC and DC coupling	16
4.3.	Attenuator and trigger level control	16
4.4.	Separate and common via B mode	17
4.5.	Positive and negative slope triggering	17
4.6.	Hold off	17

### 5. Basic measurement

5.1.	Check PM 6622	18
5.2.	Check PM 6624 . . . 25	19
5.3.	Frequency A PM 6622 . . . 25	20
5.4.	Frequency C PM 6624 . . . 25	20
5.5.	Period B PM 6622 . . . 25	21
5.6.	Time Interval A to B PM 6622 . . . 25	22
5.7.	Ratio A/B PM 6622 . . . 25	22
5.8.	Ratio C/B PM 6624 . . . 25	23
5.9.	Count A Start/Stop and Gated by B PM 6622 . . . 25	24
5.10.	Hold off PM 6622	25

### VII. Internal checks and adjustments

1.	Location of trimmers and test points	26
2.	Test equipment	26
3.	D.C. voltages	26
4.	D.C. balance channel A	26
5.	Frequency compensation channel A	26
6.	DC balance channel B	26
7.	Frequency compensation channel B	26

### VIII. Oscillators PM 9677, PM 9678, PM 9679 and PM 9690

1.	General	28
2.	Technical data	28
3.	Frequency adjustment PM 9677	29
4.	Frequency adjustment PM 9678	29
5.	Frequency adjustment PM 9679	29

6.	Frequency adjustment PM 9690	29
7.	Repair of oscillators PM 9679 and PM 9690	29
8.	Pin configuration	29
9.	Circuit diagram, component layout and spare parts list PM 9677	30
10.	Circuit diagram, component layout and spare parts list PM 9678	31
<b>IX.</b>	<b>Replacing parts</b>	<b>32</b>
1.	Push-button switches	32
2.	Text plate and front rim	32
3.	Handle	32
4.	Power supply	32
<b>X.</b>	<b>Spare parts, circuit description of power supply and prescaler units, test conditions and circuit diagrams</b>	<b>33</b>
1.	Spare parts Unit 1 PM 6622 . . . 25	33
2.	Spare parts prescaler PM 6624	36
3.	Spare parts prescaler PM 6625	37
4.	Mechanical parts PM 6622 . . . 25	35
5.	Circuit description prescaler PM 6624 . . . 25 and power supply	39
6.	Test conditions	41
7.	Circuit diagrams	43

#### List of figures

IV-1	Mains transformer connections	9
V-1	Top view of PM 6622 . . . 25	15
V-2	Bottom view of PM 6622 . . . 25	15
VI-1	AC/DC coupling	16
VI-2	Triggering	17
VI-3	COM via B mode	17
VI-4	Positive and negative slope triggering	17
VI-5	Simple pulse width measurement	17
VI-6	Period average measurement	21
VI-7	Single period measurement	21
VI-8	Start/Stop by B measurement	24
VI-9	Gated by B measurement	24
VI-10	Time interval measurement on noisy signals	25
VIII-1	Oscillator PM 9677	30
VIII-2	Oscillator PM 9677	30
VIII-3	Oscillator PM 9678	31
VIII-4	Oscillator PM 9678	31
IX-1	Replacing push-button switch	32
IX-2	Removing the front rim	32
X-1	Current paths in DC-to-DC converter	40
X-2	Component layout U1	46
X-3	Input/Output amplifier D, Oscillator, decimal counting unit, display and time base divider	52
X-4	Input amplifier A and B	58
X-5	Power supply	62
X-6	Prescaler PM 6624	64
X-7	Prescaler PM 6624	64
X-8	Prescaler PM 6624	66
X-9	Prescaler PM 6625	68
X-10	Prescaler PM 6625	68
X-11	Prescaler PM 6625	70

## I. INTRODUCTION

## GENERAL INFORMATION

The counters in the PM 6620-series have frequency ranges from D.C. up to 80 MHz, 520 MHz and 1 GHz respectively for the PM 6622, PM 6624 and PM 6625.

All models can measure frequency, ratio, period, time interval and have a totalizing mode.

Optional accessories such as four different oscillators, a battery unit, a BCD output unit, a D/A converter and a BUS interface system extend the range of application.

## II. TECHNICAL DATA

Properties expressed in numerical values with statement of tolerances are guaranteed. Numerical values without tolerances are intended for information purposes only and indicate the properties of an average instrument. The numerical values hold good for the nominal mains voltage.

### A. MEASUREMENTS

#### Frequency

Range	DC ... 80 MHz. Input A. All models 50 ... 520 MHz. Input C. PM 6624 50 ... 1000 MHz. Input C. PM 6625
Gate times	10 ms, 100 ms, 1 s and 10 s. Input A
Resolution	100 Hz, 10 Hz, 1 Hz and 0.1 Hz. All models
Accuracy	$\pm 1$ count $\pm$ time base error

#### Single Period B

Range	100 ns ... $10^5$ s (DC ... 10 MHz)
Frequency counted	10 MHz or 10 kHz
Time resolution	100 ns or 100 $\mu$ s
Accuracy	$\pm 1$ count $\pm$ trigger error* $\pm$ time base error

#### Period average B

Range	1 Hz ... 10 MHz
Frequency counted	10 MHz
Number of averagings	$N = 10^2, 10^4$ and $10^6$
Time resolution	$\frac{100 \text{ ns}}{N}$
Accuracy	$\pm 1$ count $\pm$ trigger error*/ $N$ $\pm$ time base error

#### Time interval A—B

	Single	Average
Range	100 ns ... $10^5$ s	1 ns ... 1 s
Frequency counted	10 MHz or 10 kHz	10 MHz
Time resolution	100 ns or 100 $\mu$ s	$\frac{100 \text{ ns}}{\sqrt{N}}$
Number of averagings		$N = 10^2, 10^4, 10^6$
Min. time stop to start		250 ns
Accuracy	$\pm 1$ count $\pm$ trigger error** $\pm$ time base error	$\pm 5$ ns $\pm$ time base error $\pm 100 \text{ ns} \pm \frac{\text{trigger error}^{**}}{\sqrt{N}}$
Time interval repetition rate	max. 5 MHz	max. 4 MHz



**Count A**

Range	1 to 999999999
Mode	Accumulates pulses on channel A during time interval between start and stop signal or gate signal at input B
Pulse pair resolution	12 ns

**Frequency ratio A/B or C/B**

Range	fA: DC ... 80 MHz. All models fB: DC ... 10 MHz. All models fC: 50 ... 520 MHz. PM 6624 fC: 50 ... 1000 MHz. PM 6625
Multiplier	$N = 10^4$ and $10^6$
Accuracy	$\pm 1 \text{ count} \pm \frac{\text{trigger error}^* \text{ of B}}{N}$

**Check**

HOLD OFF on 10 MHz internally applied to channel A and B  
The hold off duration will be displayed if SINGLE PERIOD B is selected.  
PM 6622.

**Auxiliary functions**

Reset	Pushing RESET button resets the counter, releasing it starts new measurement.
Start/Stop and Gated by B	In function COUNT A the gate time is controlled either by start/stop or gate signal at input B. Mode of operation is selected by a slide switch at the front panel.
Display time	Continuously variable between 0.2 ... 5 s and infinite of display time knob is pulled.
Stand by	The switch is combined with display time control. Position STAND BY keeps an oven oscillator heated.
Memory	Switchable by push-button MEMORY
Trigger hold off	Active in the time-interval and the period mode. PM 6622.
Range	Approximately 10 ... 500 $\mu$ s, 500 $\mu$ s ... 100 ms if control knob is pulled. Hold off time is monitored at output gate open.

\* Trigger error is  $\leq \pm 3 \times 10^{-3}$  for sine wave signals with signal to noise ratio of  $\geq 40$  dB.

\*\* Trigger error for any wave shape is  $\leq \pm \frac{2.5 \times 10^{-3}}{\text{Signal slope (V/ns)}} \text{ ns}$

**B. INPUT CHARACTERISTICS****Input A and B**

Range	DC ... 80 MHz	} Input B is functionally limited to 10 MHz
DC coupled	100 Hz ... 80 MHz	
AC coupled	Sine wave: 20 mV <sub>rms</sub>	
Sensitivity	Pulses: 60 mV <sub>p-p</sub> for pulse width $\geq 6$ ns	
Impedance	1 M $\Omega$ //25 pF	
Coupling	DC and AC	
Attenuation	$\times 1$ and $\times 10$	
Trigger level	Preset 0 V or variable between $\pm 2.5$ V with high resolution around 0 V.	
Safe overload		
Attenuation $\times 1$	$\leq 440$ Hz: 250 V DC or 230 V <sub>rms</sub>	
	$> 440$ Hz: falling to 12 V <sub>rms</sub> at 1 MHz	
Attenuation $\times 10$	Max. 250 V DC or 230 V <sub>rms</sub> .	

**Input C**

(Not present in PM 6622)

	<b>PM 6624</b>	<b>PM 6625</b>
Frequency range	50 ... 520 MHz	50 ... 1000 MHz
Dynamic voltage range	10 mV <sub>rms</sub> ... 12 V <sub>rms</sub> (-27 dBm ... +35 dBm)	10 mV <sub>rms</sub> ... 12 V <sub>rms</sub> (-27 dBm ... +35 dBm)
Impedance	50 Ω	50 Ω
VSWR	<2	<2
Coupling	AC	AC
Attenuation	by automatic PIN diode attenuator, maximum 62 dB.	
Prescaling factor	8	16
Safe overload	12 V <sub>rms</sub>	12 V <sub>rms</sub>
AM tolerance	98 % at 5 kHz modulation frequency } All models 30 % at 1 MHz modulation frequency }	

**D OUT/IN 10 MHz**

	External oscillator input or internal oscillator output. Selectable by a switch at the rear panel.
Range	1 kHz ... 10 MHz
Sensitivity	500 mV <sub>rms</sub>
Coupling	AC
Impedance	≈ 10 kΩ
Safe overload	50 V <sub>rms</sub>

**EXT. RESET/START**

	0 V ±0.4 V applied to EXT. RESET input will reset the counter. If DISPLAY TIME is set to position ∞ one new measurement will be initiated when the EXT. RESET is returned to > +2.4 V (max. 5.5 V) or the input is left open.
Input current	Max. 0.4 mA at 0.4 V

\* Above 960 MHz, the sensitivity of the PM 6625 might drop to 14 mV<sub>rms</sub> (-24 dBm) at 1 GHz

**C. OUTPUT CHARACTERISTICS**

**D OUT/IN 10 MHz**

	Internal oscillator output or external oscillator input. Selectable by a switch at the rear panel.
Output frequency	Internal oscillator frequency, 10 MHz.
Signal level	≈ 1 V <sub>rms</sub> , open circuit.
Output impedance	≈ 200 Ω, short circuit proof.
Coupling	DC

**GATE OPEN**

Output level	< 0.4 V during main gate open ≈ 1.5 during hold off time. PM 6622 > 2.5 V during main gate closed.
Output impedance	≈ 400 Ω.
Delay	Internal delay between the signal inputs and the trigger monitor output is approximately 65 ns.

**DISPLAY**

9 digits.  
In plane 7 segment gas discharge display with decimal point indication.

**Gate lamp**

Indicates that main gate is open and counting takes place.  
In stand by position the Gate lamp indicates that mains or battery voltage is connected.

**Unit annunciators**

kHz, MHz, ms and ns.

## D. GENERAL CHARACTERISTICS

<b>Oscillator</b>	See Chapter VIII.
<b>Supply</b>	
By mains	100...130 V or 200...260 V, 50...400 Hz max. 20 VA depending on options.
By external battery	+ 11.5 to 28 V approximately 8 W.
By internal battery option	PM 9673
<b>Environmental characteristics</b>	
Temperature	
Operating	0° C...50° C
Storage	0° C...40° C with battery option PM 9673. —40° C...70° C —40° C...50° C with battery option PM 9673.
Mains interference	Below CISPR (22/3, 29/2 and 40/1)
Altitude	5000 m operating 15000 m storage.
Shock	Meets the requirements of the IEC 68 Eb recommendations.
Vibration	Meets the requirements of the IEC 68 F recommendations.
<b>Dimensions</b>	
Width	210 mm
Height	89 mm
Depth	325 mm
Weight	Approximately 2.8 kg.

## III. ACCESSORIES

### 1. Standard accessories supplied with the instrument

1 mains cable	PM 9584 Resistive mixing piece, 50 $\Omega$ , 3 BNC sockets
1 manual	
1 1.6 A fuse, fast action	PM 9346 Active-probe power supply
1 "115 V" label	

### 2. Accessories to be ordered separately

#### 2.1. Oscillators

PM 9677 Standard oscillator
PM 9678 TCXO
PM 9679 Oven-enclosed oscillator $1 \times 10^{-7}$ /month
PM 9690 Oven-enclosed oscillator $1.5 \times 10^{-9}$ /24 h.

#### 2.2. Output interface units

PM 9674 BCD output unit
PM 9675 D/A converter

#### 2.3. Input interface accessories

PM 9351 Passive measuring probe 10 M $\Omega$ ,/11 pF 220 MHz, attenuation 10 $\times$
PM 9353 FET probe, 1M $\Omega$ /3.5F, 220 MHz

#### 2.4. Coaxial cables

PM 9074 50 $\Omega$ , BNC to BNC, length 1 m
PM 9588 Set of 50 $\Omega$ cables, BNC to BNC: 5 cables, length 20.7 cm 4 cables, length 40.5 cm 3 cables, length 60.3 cm 3 cables, length 198.6 cm

#### 2.5. Mains cable

PM 9011 3-core detachable mains cable
---------------------------------------

#### 2.6. Rack mount adapter

PM 9669 19" rack mount adapter
--------------------------------

#### 2.7. Battery unit

PM 9673 Internal battery unit
-------------------------------

#### 2.8. Carrying case

PM 9672 Carrying case for the instrument
--

## IV. INSTALLATION

### 1. Mains voltage conversion

The instrument can be converted into two mains voltage ranges 100—130 V and 200—260 V. The frequency range is 50 to 400 Hz. At delivery the instrument is set to the 200 to 260 V range.

When changing to the 100 to 130 V range the connections of the mains transformer should be changed as shown in figure IV-1, and the label "230 V" covered with the "115 V" label supplied.

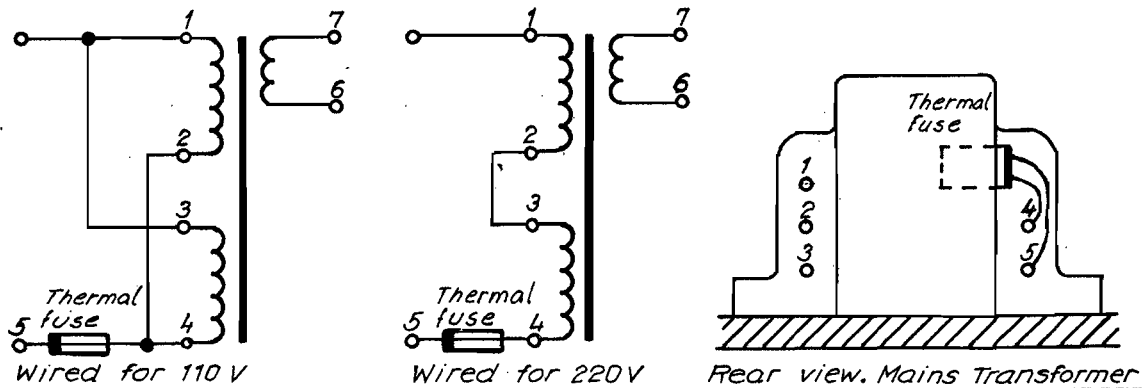

Figure IV-1. Mains transformer connections

### 2. Earthing

The local safety regulations prescribe how the instrument should be earthed. Two ways are possible:

1. Via the protective earth terminal at the rear panel.
2. Via the three core mains cable plugged into an outlet with protective earth contact.

**NOTE:** Use only **one** of these alternatives to avoid hum!

### 3. Fuses

A thermal fuse on the mains transformer and a 1.6 A fuse, fast action, on unit U1 are protecting the power supply.

### 4. Optional accessories

Refer to installation instruction given in manual for each type number.



## V. CONTROLS, INDICATORS AND CONNECTORS

Front panel PM 6624 and PM 6625

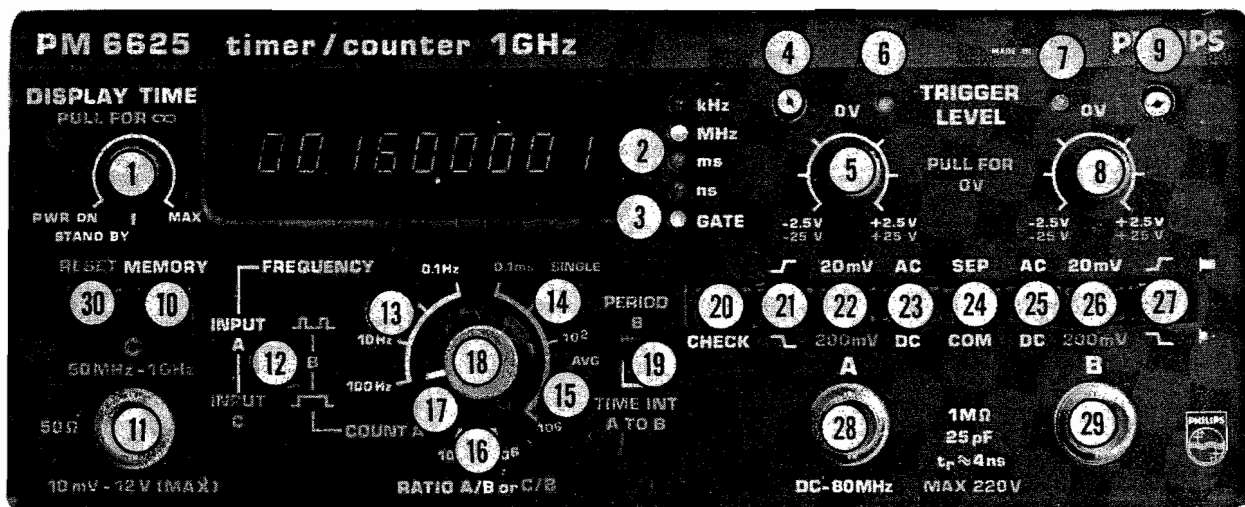

### 1. Display time control

Potentiometer sets display time between 0.2 s and 5 s. Infinite display time when knob is pulled. With switch set to position STAND BY the counter is turned off except of the oven oscillator.

**Warning:** Primary voltage of power supply is on.

### 2. kHz, MHz, ms and ns

Unit annunciators.

### 3. Gate lamp

Indicates that main-gate is opened and counting takes place, in the stand-by position the gate lamp indicates that the line voltage or battery is connected for X-tal oscillator stabilization.

### 4. Monitor socket channel A

Output socket for set trigger level.

### 5. Trigger control channel A

Sets trigger level from  $-2.5$  V to  $+2.5$  V when the attenuator is in position 20mV, and from  $-25$  V to  $+25$  V when the attenuator is in position 200 mV. Knob pulled sets trigger level to 0 V.

### 6. Trigger lamp channel A

Tri-state control lamp for set trigger level. Blinking lamp indicates that the set trigger level matches the level of the input signal. Lamp permanently on indicates that the set trigger level is too high, and lamp turned off indicates that set trigger level is too low.

### 7. Trigger lamp channel B

Same as trigger lamp channel A.

### 8. Trigger control channel B

Same as trigger control channel A.

### 9. Monitor socket channel B

Same as monitor socket channel A.

### 10. Memory

In released position the measurement information is stored until next measurement cycle is completed. Depressed button makes display follow decade counters continuously.

### 11. Input C

Input socket for frequency and ratio measurement.

### 12. Start-Stop by B/Gated by B and Input A/Input C

In the upper position it sets counter to measure Count A Start-Stop by B, Frequency A, or Ratio A/B and in the lower position it sets counter to measure Count A Gated by B, Frequency C or Ratio C/B depending on how the Function Selector is set.

### 13. Frequency A and C

Sets counter to measure frequency at inputs A and C. 100 Hz, 10 Hz, 1 Hz and 0.1 Hz correspond to the resolution of the least significant digit.

### 14. Single

Sets counter to measure Single Period B or Single Time Interval A to B. Time resolution can be set to 0.1 ms or 0.1  $\mu$ s.

**15. Average**

Sets counter to measure Multiple Period B or Time Interval Average A to B.  $10^2$ ,  $10^4$  and  $10^6$  are number of averagings.

**16. Ratio A/B or C/B**

Combined with Input A/Input C switch it selects Ratio A/B or Ratio C/B measurement.  $10^4$  and  $10^6$  are multipliers.

**17. Count A**

Sets counter to accumulate pulses between Start to Stop or Gated by B measurements.

**18. Function selector**

Combined with the two slide switches it selects the different measuring modes.

**19. Period B/Time interval A to B**

Sets counter to measure Period B or Time interval A to B.

**20. Self check**

Connects 10 MHz from the internal oscillator to the input circuits of the counter.

**21. Slope selector channel A**

Sets counter to trigger on either positive or negative slope of the input signal.

**22. Attenuator channel A**

Provides  $10\times$  attenuation of the input signal.

**23. AC/DC selector channel A**

Selects AC or DC coupling of the input signal.

**24. Separate/Common via B**

Connects channel A and B internally in position COM VIA B. In position SEP the input channels are separated.

**25. AC/DC selector channel B**

Same as AC/DC selector channel A.

**26. Attenuator channel B**

Same as attenuator channel A.

**27. Slope selector channel B**

Same as slope selector channel A.

**28. Input A**

Input socket for frequency, ratio and time interval measurement.

**29. Input B**

Input socket for period, ratio and time interval measurement.

**30. Reset**

Resets counter and display to zero.

## V. CONTROLS, INDICATORS AND CONNECTORS

Front panel PM 6622

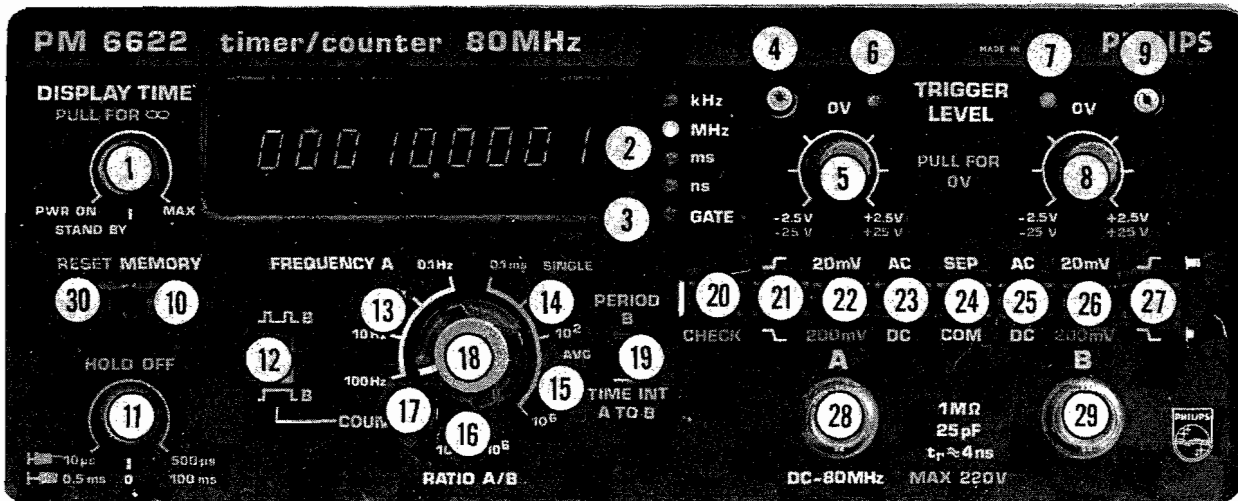

### 1. Display time control

Potentiometer sets display time between 0.2 s and 5 s. Infinite display time when knob is pulled. With switch set to position STAND BY the counter is turned off except of the oven oscillator.

**Warning:** Primary voltage of power supply is on.

### 2. kHz, MHz, ms and ns

Unit annunciators.

### 3. Gate lamp

Indicates that main-gate is opened and counting takes place, in the stand-by position the gate lamp indicates that the line voltage or battery is connected for X-tal oscillator stabilization.

### 4. Monitor socket channel A

Output socket for set trigger level.

### 5. Trigger control channel A

Sets trigger level from  $-2.5\text{ V}$  to  $+2.5\text{ V}$  when the attenuator is in position 20mV, and from  $-25\text{ V}$  to  $+25\text{ V}$  when the attenuator is in position 200 mV. Knob pulled sets trigger level to 0 V.

### 6. Trigger lamp channel A

Tri-state control lamp for set trigger level. Blinking lamp indicates that the set trigger level matches the level of the input signal. Lamp permanently on indicates that the set trigger level is too high, and lamp turned off indicates that set trigger level is too low.

### 7. Trigger lamp channel B

Same as trigger lamp channel A.

### 8. Trigger control channel B

Same as trigger control channel A.

### 9. Monitor socket channel B

Same as monitor socket channel A.

### 10. Memory

In released position the measurement information is stored until next measurement cycle is completed. Depressed button makes display follow decade counters continuously.

### 11. Hold off control

In Single Period and Single Time Interval this control disables retriggering of the main gate until the set hold off time is out.

### 12. Start/stop by B-Gated by B

In the upper position it sets counter to measure Count A Start-Stop by B, in the lower position counter will measure Count A Gated by B.

### 13. Frequency A

Sets counter to measure frequency at input A. 100 Hz, 10 Hz, 1 Hz and 0.1 Hz correspond to the resolution of the least significant digit.

### 14. Single

Sets counter to measure Single Period B or Single Time Interval A to B. Time resolution can be set to 0.1 ms or 0.1  $\mu\text{s}$ .

**15. Average**

Sets counter to measure Multiple Period B or Time Interval Average A to B.  $10^2$ ,  $10^4$  and  $10^6$  are number of averagings.

**16. Ratio A/B**

Sets counter to measure ratio between signals at input A and B.  $10^4$  and  $10^6$  are multipliers.

**17. Count A**

Sets counter to accumulate pulses between Start to Stop or Gated by B measurements.

**18. Function selector**

Combined with the two slide switches it selects the different measuring modes.

**19. Period B/Time interval A to B**

Sets counter to measure Period B or Time interval A to B.

**20. Self check**

Connects 10 MHz from the internal oscillator to the input circuits of the counter.

**21. Slope selector channel A**

Sets counter to trigger on either positive or negative slope of the input signal.

**22. Attenuator channel A**

Provides  $10\times$  attenuation of the input signal.

**23. AC/DC selector channel A**

Selects AC or DC coupling of the input signal.

**24. Separate/Common via B**

Connects channel A and B internally in position COM VIA B. In position SEP the input channels are separated.

**25. AC/DC selector channel B**

Same as AC/DC selector channel A.

**26. Attenuator channel B**

Same as attenuator channel A.

**27. Slope selector channel B**

Same as slope selector channel A.

**28. Input A**

Input socket for frequency, ratio and time interval measurement.

**29. Input B**

Input socket for period, ratio and time interval measurement.

**30. Reset**

Resets counter and display to zero.

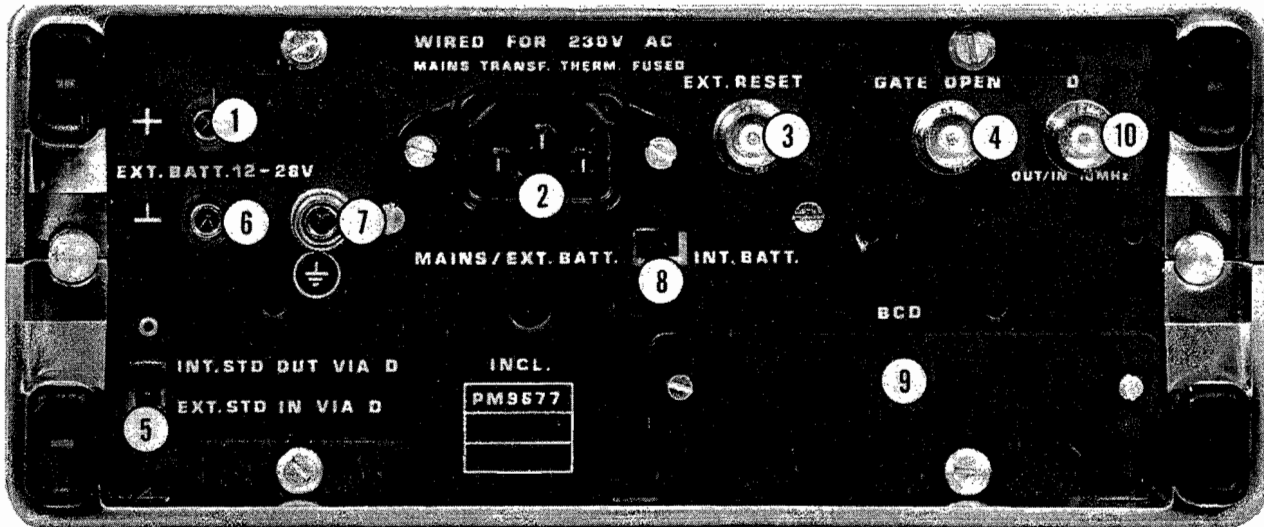

## Rear panel PM 6622 . . . 25

**1. External battery socket**

Plus pole input socket for external battery.

**2. Mains input**

Input socket for the mains.

**3. External reset input**

Input socket for reset/start signal.

**4. Monitor socket gate signal**

Output socket for gate and hold off (PM 6622) signals.

**5. Internal/External Standard switch**

Sets operating mode of input D to either internal 10 MHz out or external 10 MHz in.

**6. External battery socket**

Minus pole input socket for external battery.

**7. Chassis ground**

Protective earth terminal.

**8. Mains/Battery switch**

Sets power supply to be fed from external or internal power source.

**9. BCD and D/A connector**

Output connector for the BCD and D/A units.

**10. Internal/External Standard socket**

10 MHz out or external 10 MHz in.

Top view PM 6622 . . . 25

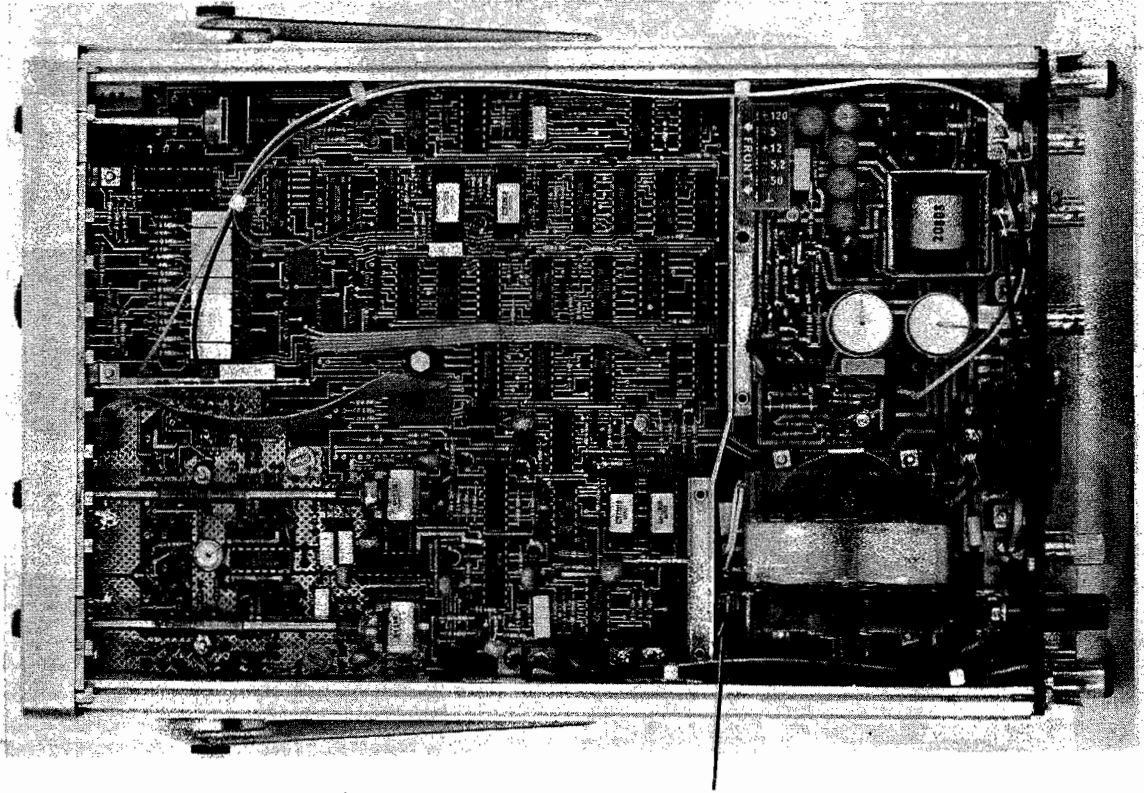

Fig. V-1. Top view of PM 6622 . . . 25

1.6 A fuse fast action.

Bottom view PM 6622 . . . 25

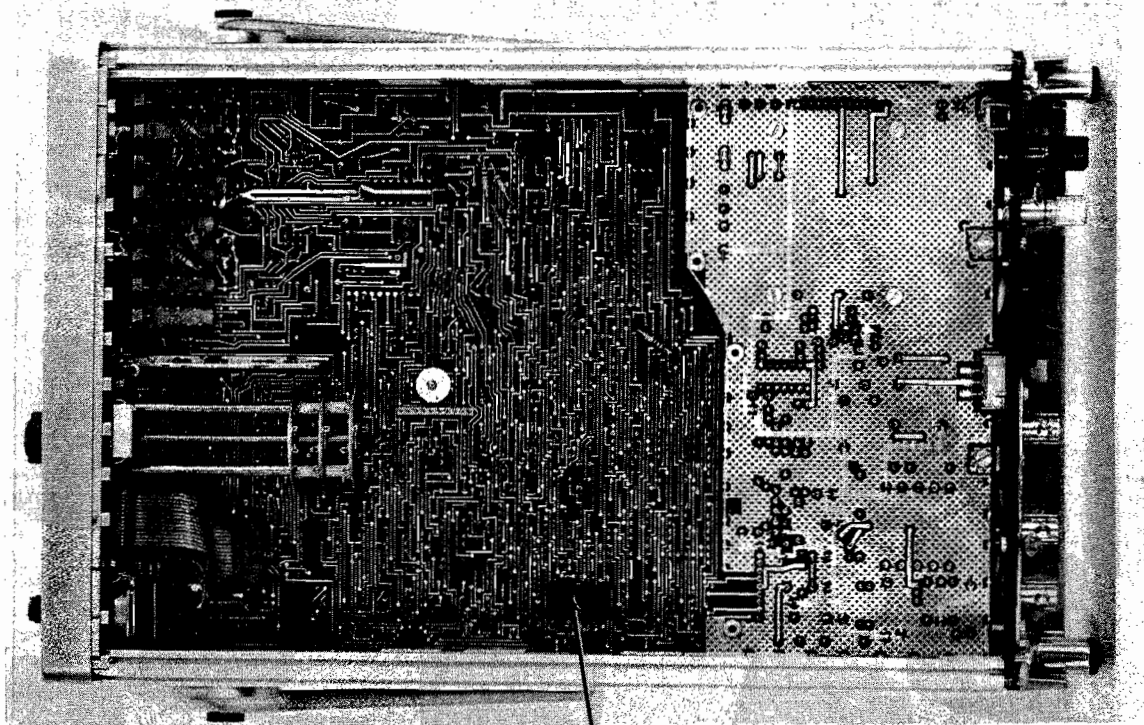

Fig. V-2. Bottom view of PM 6622 . . . 25

Connector for D/A and BCD unit.

## VI. OPERATION

### General Information

#### 1. Switch on power

##### 1.1. Mains

Before the counter is connected to the mains check that the mains transformer is wired for the local mains voltage as described in chapter IV.1. Mains voltage conversion

- Set switch MAINS EXT. BATT/INT. BATT on the rear panel to position MAINS EXT. BATT.
- Connect the mains cable to input socket for the mains at the rear panel.
- Set DISPLAY TIME control at the front panel to position ON.
- Check that display turns on indicating that power is on.

##### 1.2. External battery

- Set switch MAINS EXT. BATT/INT. BATT at the rear panel to position MAINS EXT. BATT.
- Connect the cables from the external battery to sockets EXT. BATT. 12—28 V at the rear panel.
- Set DISPLAY TIME at the front panel control to position ON.
- Check that display turns on indicating that power is on.

##### 1.3. Internal battery PM 9675

- Set switch MAINS EXT. BATT/INT. BATT. at the rear panel to position INT. BATT.
- Set DISPLAY TIME control at the front panel to position ON.
- Check that display turns on indicating that power is on. Blinking display indicates low voltages. Refer to manual PM 9673 for charging instructions.

#### 2. Warm up time

The warm up time from the moment of mains connection is less than 7 minutes to an oscillator error of less than  $10^{-7}$  for instruments equipped with the oven-enclosed oscillators PM 9679 and PM 9690. Instruments equipped with the oscillators PM 9677 or PM 9678 (TCXO) are ready for use at the moment of mains connection.

Normally the instrument is switched on from the STAND BY position. If so, no warm up time is needed, irrespective of which oscillator is employed.

#### 3. External frequency standards

House standards or other frequency standards can be used instead of the internal 10 MHz oscillator.

If a time resolution of 100 ns is required, 10 MHz must be used. When using 1 MHz instead of 10 MHz the decimal point must be shifted one step to the left to interpret the display correctly. To set the counter to external standard the switch EXT. STD OUT VIA D/EXT. STD IN VIA D at the rear panel must be set to position EXT. STD IN VIA D.

#### 4. Control settings

##### 4.1. A, B and C inputs

The A and B amplifiers are identical in specification and provided with identical input controls.

The A input is normally used for frequency measurement and the B input for time measurement.

The C input is a prescaler input with automatic PIN-diode attenuator and mainly used for high frequency measurement.

##### 4.2. AC and DC coupling

The AC/DC push-button controls the coupling of the input signal to the attenuator and the amplifier by switching a capacitor in series in the AC mode and by direct coupling in the DC mode.

A.C. coupling is normally used to block the d.c. component in signals which are superimposed on a d.c. voltage. The capacitor in series will, however, cause a falling sensitivity for low frequencies.

In waveforms where pulse width and repetition time vary the d.c. level will also vary. Change in the d.c. level will cause changes in the preset triggering level and make accurate time measurements impossible if A.C. coupled, in such cases the input should be D.C. coupled.

Normally frequency measurements are performed with an A.C. coupled input and time interval measurements with a D.C. coupled input.

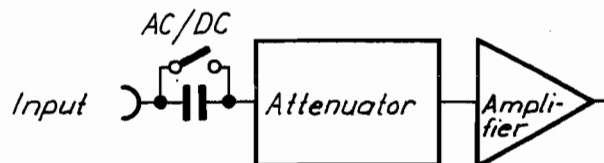

Fig. VI-1. AC/DC coupling

##### 4.3. Attenuator and Trigger Level.

The TRIGGER LEVEL control allows continuous setting of the trigger level at any point of the input signal. For high amplitude signals the attenuator is used to expand the setting range.

However, input attenuation will decrease the sensitivity and cause bigger trigger errors.

For frequency measurements on sine wave and other symmetrical signals no level off-set is required. Pulled position of the TRIGGER LEVEL control sets the trigger level to 0 V for highest sensitivity.

However, for frequency measurement on narrow pulses a limited off-set voltage may be needed to obtain reliable triggering.

Time measurement requires continuously variable setting of the trigger level.

Monitor sockets for channel A and B provide the ability to measure the set trigger level.

If the attenuator is set to 200 mV the trigger level range is increased 10 times from  $\pm 2.5$  V to  $\pm 25$  V.

The name trigger level can be misleading, since triggering does not occur on the set trigger level but at the trigger point—see figure VI-2.

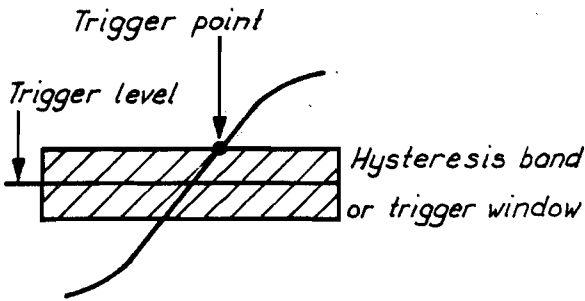

Fig. VI-2. Triggering

4.4. Separate and Common via B mode

In the SEP position the A and B inputs operate independently of each other in any operations irrespective of input sources. In the COM position the A input is disconnected from its attenuator and amplifier, and a signal connected to input B is coupled to both A and B attenuators and amplifiers.

All input specifications of input B will remain the same but the input impedance will be 500 kΩ shunted by 50 pF.

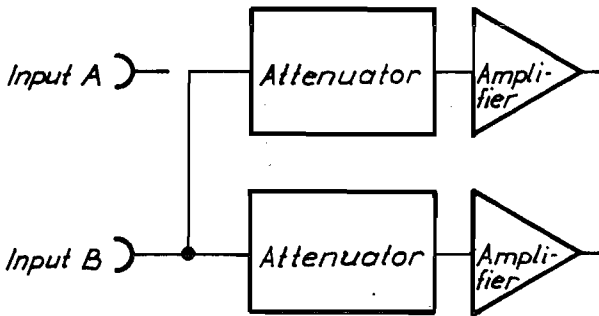

Fig. VI-3. COM via B mode

4.5. Positive and negative slope triggering

This push-button determines on which slope of the input signal the triggering will occur.

In released position the triggering will occur at the positive slope of the input signal and in depressed position it will occur on the negative slope.

Where on the slope the triggering will occur is determined by the TRIGGER LEVEL control.

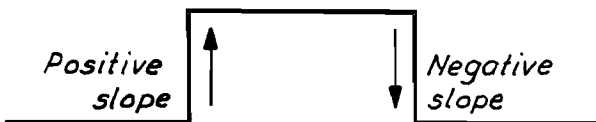

Fig. VI-4. Positive and negative slope triggering

A simple way to measure the pulse width of a positive pulse is achieved by setting input A to positive slope and input B to negative slope, connect the pulse to input B, set FUNCTION SELECTOR to any of the two SINGLE positions, slide switch PERIOD B/TIME INT. A TO B to position TIME INT. A TO B and SEP/COM to COM.

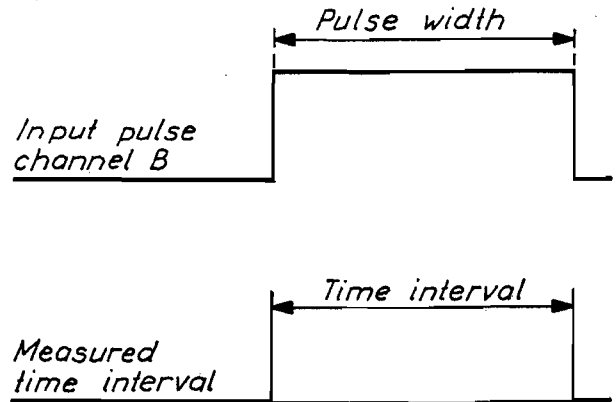

Fig. VI-5. Simple pulse width measurement

4.6. Hold off PM 6622

This control provides a delayed triggering of the instrument in single period and time interval measurement, this feature is used to avoid false triggering on noisy signals.



## 5. Basic measurements

### 5.1. CHECK PM 6622

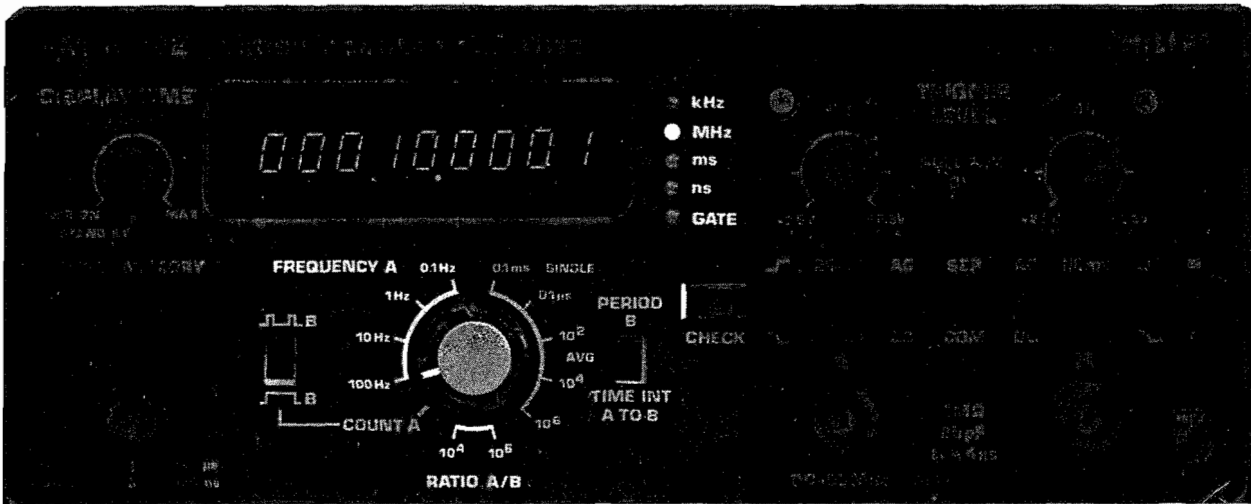

Self check of the instrument.

- Depress CHECK push-button
- Rotate FUNCTION SELECTOR and read:

#### Frequency A

100 Hz	00010.0000
10 Hz	0010.00000
1 Hz	010.000000
0.1 Hz	10.0000000

— Set PERIOD B/TIME INT A TO B to PERIOD B

#### Period B

0.1 ms	00000000.0
0.1 ns	00000.0001
$10^2$	000000100
$10^4$	0000100.00
$10^6$	00100.0000

#### Ratio A/B

$10^6$	001.000000
$10^4$	00001.0000

#### Count A

Start/Stop	000000002
Gated	000000001

## 5.2. CHECK PM 6624 . . . 25



Self check of the instrument.

- Depress CHECK push-button
- Set INPUT A/INPUT C to INPUT A
- Rotate FUNCTION SELECTOR and read:

## FREQUENCY A

100 Hz	00010.0000 MHz
10 Hz	0010.00000 MHz
1 Hz	010000.000 kHz
0.1 Hz	10000.0000 kHz

- Set PERIOD B/TIME INT A TO B to PERIOD B

## PERIOD B

0.1 ms	00000000.0
0.1 ns	00000.0001
10 <sup>2</sup>	000000100
10 <sup>4</sup>	0000100.00
10 <sup>6</sup>	00100.0000

## RATIO A/B

10 <sup>6</sup>	001.000000
10 <sup>4</sup>	00001.0000

- Set INPUT A/INPUT C to INPUT C

## RATIO C/B PM 6624

10 <sup>4</sup>	008.000000
10 <sup>6</sup>	00008.0000

## RATIO C/B PM 6625

10 <sup>4</sup>	016.000000
10 <sup>6</sup>	00016.0000

## COUNT A

Start/Stop	000000002
Gated	000000001

## FREQUENCY C PM 6624

100 Hz	00080.0000 MHz
10 Hz	0080.00000 MHz
1 Hz	080000.000 kHz
0.1 Hz	80000.0000 kHz

## FREQUENCY C PM 6625

100 Hz	00160.0000 MHz
10 Hz	0160.00000 MHz
1 Hz	160000.000 kHz
0.1 Hz	60000.0000 kHz

## 5.3. Frequency A. PM 6622 . . . 25



Simple frequency measurement on sine waves and other symmetrical waveforms.

- Set FUNCTION SELECTOR to desired resolution
- Set INPUT A/INPUT C to INPUT A (only PM 6624 . . . 25)
- Set AC/DC to AC

- Pull TRIGGER LEVEL control
  - Set SEP/COM to SEP
  - Set 20 mV/200 mV to 200 mV if the amplitude of the input signal is higher than  $1 V_{rms}$
  - Connect the input signal to input A
- Display will show frequency in kHz or MHz

## 5.4. FREQUENCY C PM 6624 . . . 25



Automatic frequency measurement.

- Set FUNCTION SELECTOR to desired resolution
- Set INPUT A/INPUT C to INPUT C

- Connect the input signal to input C
- Display will show frequency in MHz or kHz

5.5. PERIOD B PM 6622 . . . 25

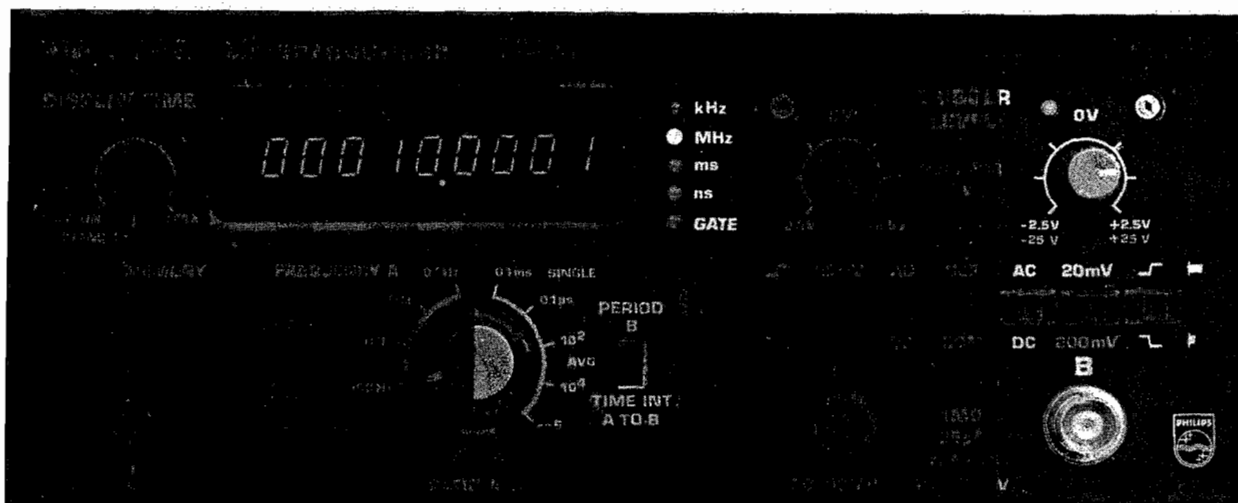

Simple period measurement on sine waves and other symmetrical waveforms.

- Set FUNCTION SELECTOR to SINGLE or AVG measurement
- Set PERIOD B/TIME INT A TO B to PERIOD B
- Pull TRIGGER LEVEL

- Set AC/DC to AC
  - Set 20 mV/200 mV to 200 mV if the amplitude of the input signal is higher than 1 V<sub>rms</sub>
  - Select positive slope triggering
  - Connect the signal to input B
- Display will show period time in ms or ns

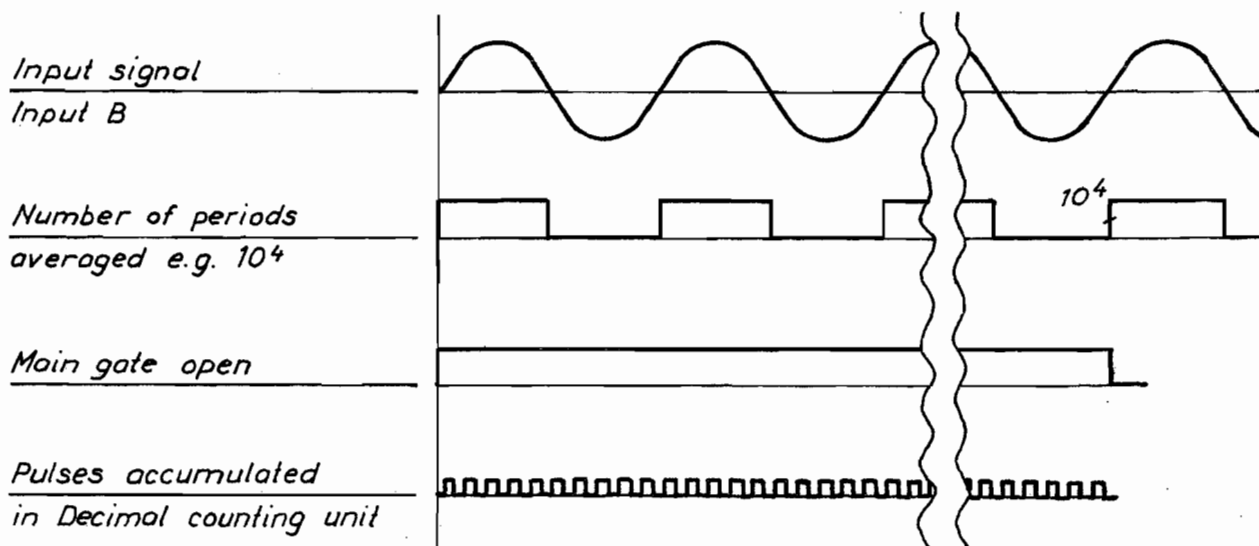

Fig. VI-6. Period average measurement

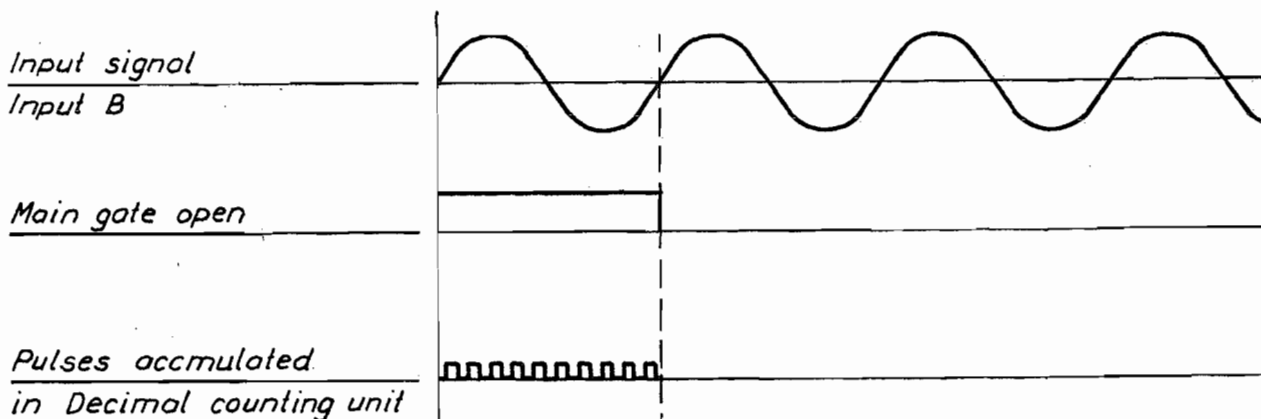

Fig. VI-7. Single period measurement

## 5.6. Time Interval A to B PM 6622 ... 25



Simple measurement of time interval between pulses at input A and B from separate sources.

- Set FUNCTION SELECTOR to SINGLE or AVG
  - Set PERIOD B/TIME INT A TO B to TIME INT A TO B
  - Set 20 mV/200 mV to 200 mV if the amplitude of the input signal is higher than  $3 V_{p-p}$
  - Set AC/DC to DC
  - Set SEP/COM to SEP
  - Select positive slope triggering
  - Set TRIGGER LEVEL potentiometer to suitable trigger level e.g. 50 % of the pulse amplitude
  - Connect the pulses to input A and B
- Display will show the time interval in ms or ns

## 5.7. Ratio A/B PM 6622 ... 25



Simple ratio measurement on sine wave or other symmetrical waveforms.

- Set FUNCTION SELECTOR to  $10^4$  or  $10^6$
  - Pull TRIGGER LEVEL control
  - Set AC/DC to AC
  - Set SEP/COM to SEP
  - Set 20 mV/200 mV to 200 mV if the amplitude of the input signal is higher than  $1 V_{rms}$
  - Connect the signal with the highest frequency to input A and the other signal to input B
- Display will show the ratio of the signal frequencies at input A and B

## 5.8. Ratio C/B PM 6624 . . . 25

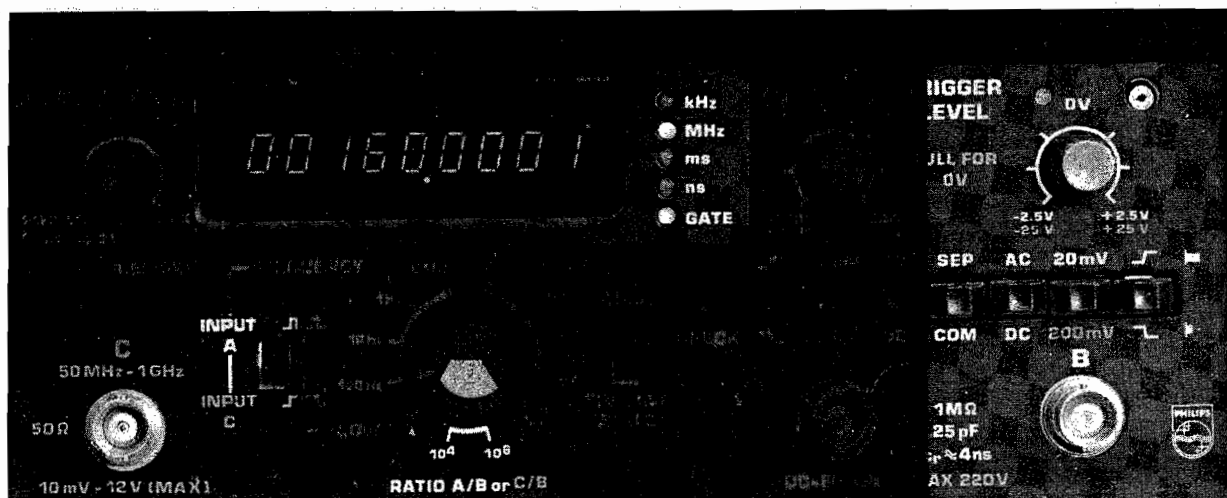

Simple ratio measurement on sine wave and other symmetrical waveforms.

- Set FUNCTION SELECTOR to  $10^4$  or  $10^6$
- Set INPUT A/INPUT C to INPUT C
- Pull TRIGGER LEVEL control
- Set SEP/COM to SEP

- Set AC/DC to AC
  - Set 20 mV/200 mV to 200 mV if the amplitude of the input signal is higher than  $1 V_{\text{rms}}$
  - Connect the signal with the highest frequency to input C and the other to input B
- Display will show the ratio of the signal frequencies at input C and B

5.9. Count A Start/Stop and Gated by B. PM 6622 . . . 25



Simple Start/Stop and Gated by B measurement on sine wave and other symmetrical waveforms.

- Set FUNCTION SELECTOR to COUNT A
- Pull TRIGGER LEVEL Control
- Set AC/DC to AC for channel A
- Set AC/DC to DC for channel B
- Set SEP/COM to SEP
- Set 20 mV/200 mV to 200 mV if the amplitude of the input signal is higher than  $1 V_{rms}$

- Select positive slope triggering
- Select Start/Stop by B (upper position) or Gated by B (lower position)
- Connect gating signal to input B and the other signal to input A

In Start/Stop operation the display will show the accumulated number of counts in the time interval between the Start/Stop signals, and in the Gated mode the accumulated number of counts during the positive and negative slopes of the Gating signal

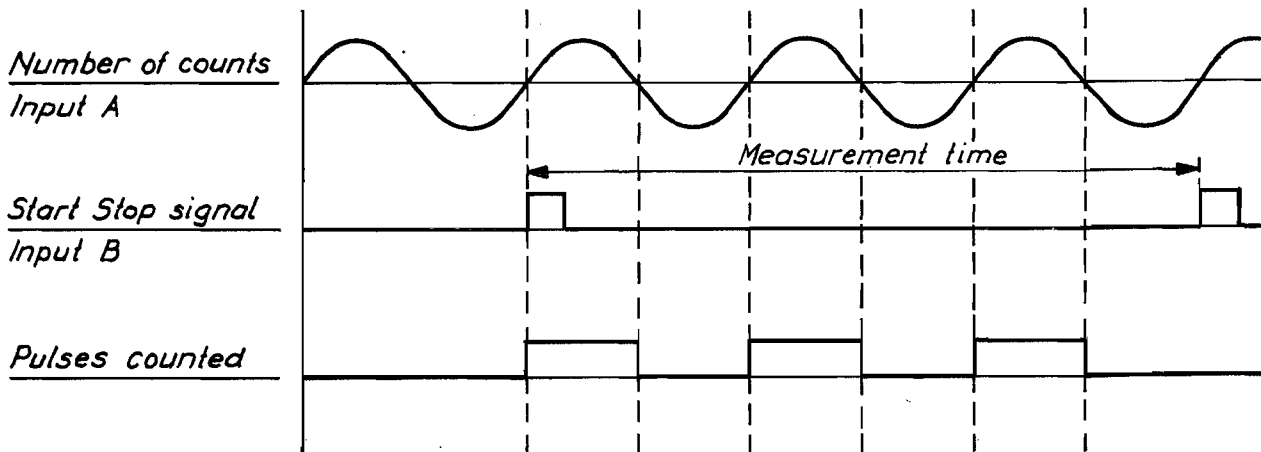

Fig. VI-8. Start/Stop by B measurement

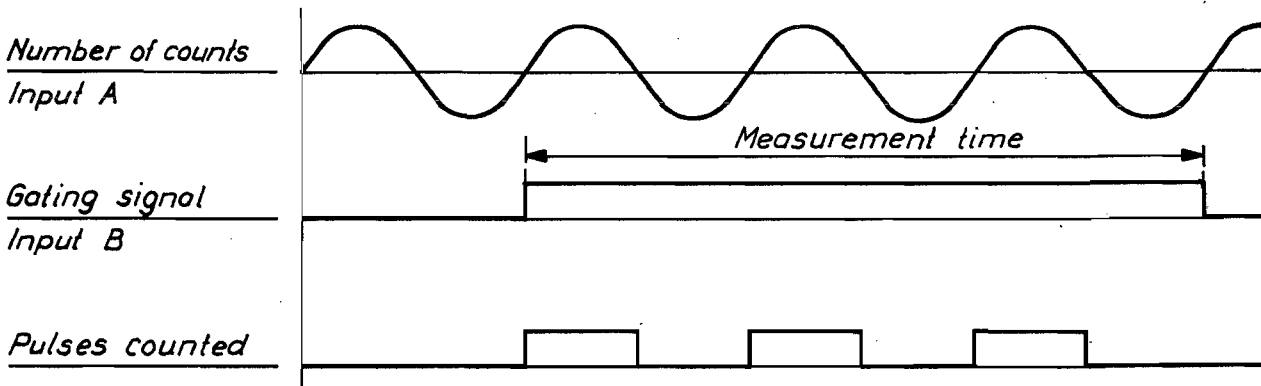
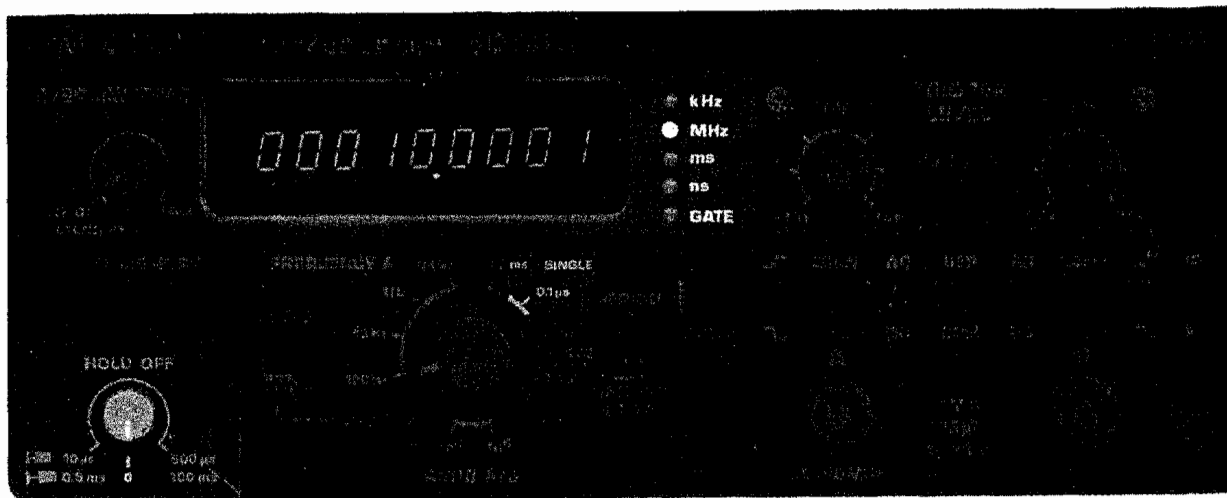

Fig. VI-9. Gated by B measurement

5.10. Hold off PM 6622



- Set FUNCTION SELECTOR to 0.1  $\mu$ s and rotate HOLD OFF control from fully CCW to fully CW position
- Read hold off time from 0.01 to 0.5 ms on the display with knob pushed and 0.5 ms to 100 ms with knob pulled

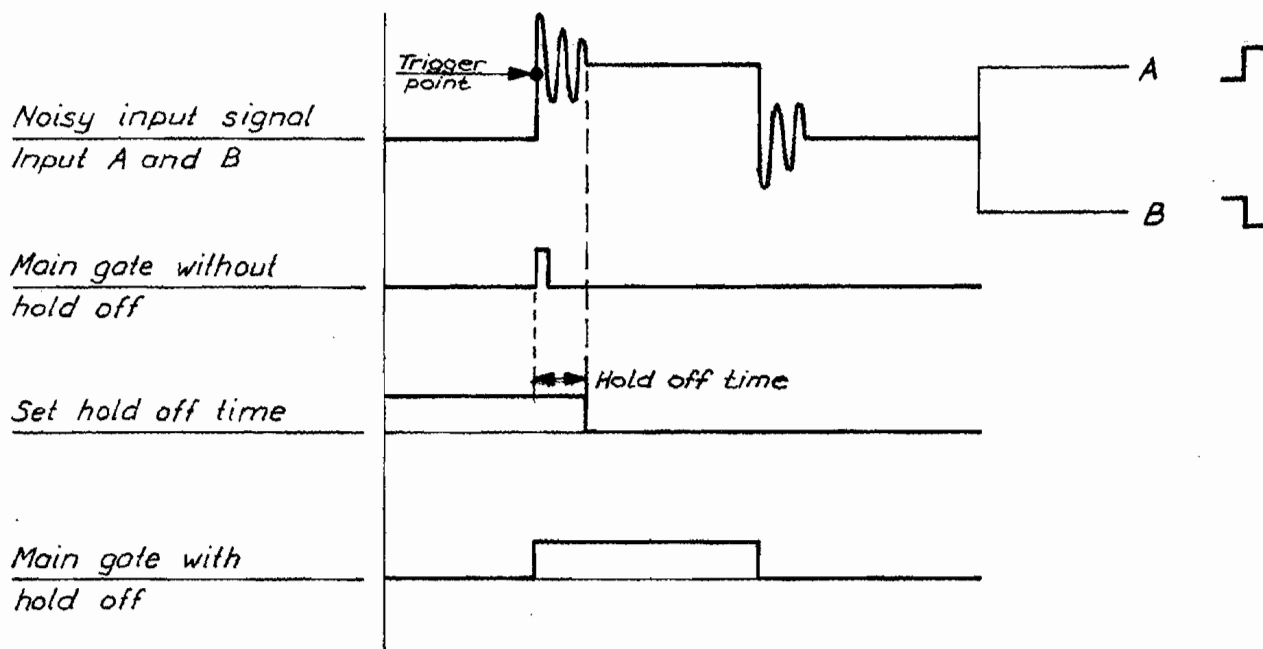

Fig. VI-10. Time interval measurement on noisy signals



## VII. INTERNAL CHECKS AND ADJUSTMENTS

The tolerances mentioned in the following text apply to newly adjusted instruments only. The value may differ from those given in Chapter II Technical data.

**Note:** Always check the d.c. supply voltages before any adjustments are made.

1. Use figure X-2 to identify the location of trimmers and check points.

### 2. Test equipment

Check point	Instrument	Required data	Recommended model
3	Voltmeter	5—150 V d.c.	Philips PM 2412
4 6	Voltmeter	1 V d.c.	Philips PM 2412
5 8	Pulsegenerator	Frequency 10 kHz Amplitude 1 V Duty factor 0.5	Philips PM 5715 or PM 5705
5 8	Oscilloscope	Low frequency	Philips PM 3250
5 8	Probe	Passive 10 M $\Omega$ /11 pF	Philips PM 9336

### 3. D.C. voltages

3.1 Connect the voltmeter to jumper connector BU 104 and check the d.c. voltages according to table below.

Test point	Measured voltage
+120	115 ... 130 V
+5.2	4.8 ... 5.2 V
+12	11.5 ... 13 V
-5.2	-5 ... -5.4 V
-50	-50 ... -60 V

### 4. D.C. balance channel A.

4.1 Disconnect all input signals, release all push-buttons and set the controls of the counter:

Start/Stop	upper position
Trigg. level pot.	pulled

4.2 Connect the voltmeter to terminal 6 of IC 101 and adjust R 1104 until voltmeter shows 0 V.

### 5. Frequency compensation channel A

Test set up.

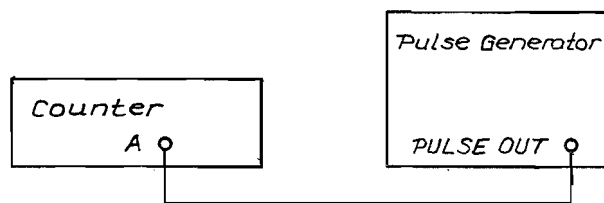

5.1 Set the controls of the counter:

Attenuator	200 mV position
------------	-----------------

5.2 Set the controls of the pulse generator:

Frequency	10 kHz
Amplitude	3 V <sub>p-p</sub>
Duty factor	0.5

5.3 Connect the oscilloscope via a well adjusted 10 M $\Omega$ /11 pF probe to terminal 6 of IC 101 and adjust C 102 to minimum distortion of the displayed wave-form.

### 6. D.C. balance channel B

6.1 Disconnect all input signals, release all push-buttons and set the controls of the counter:

Start/Stop	upper position
Trigg.level pot.	pulled.

6.2 Connect the voltmeter to terminal 12 of IC 101 and adjust R 1044 until voltmeter shows zero.

### 7. Frequency compensation channel B

Test set up.

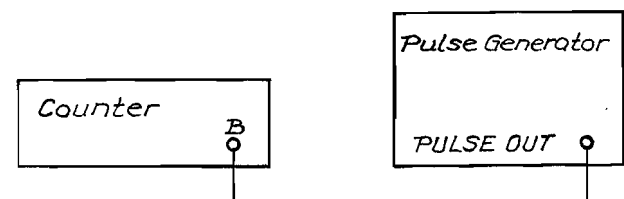

7.1 Set the controls of the counter:

Attenuator	200 mV position
------------	-----------------

7.2 Set the controls of the pulse generator:

Frequency	10 kHz
Amplitude	3 V <sub>p-p</sub>
Duty factor	0.5

7.3 Connect the oscilloscope via a well adjusted 10 M $\Omega$ /11 pF probe to terminal 12 of IC 101 and adjust C 112 to minimum distortion of the displayed wave form.

## VIII. OSCILLATORS PM 9677, PM 9678, PM 9679 and PM 9690

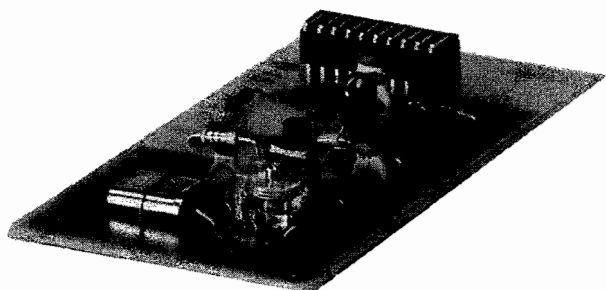
**PM 9677**

9446 096 770.1

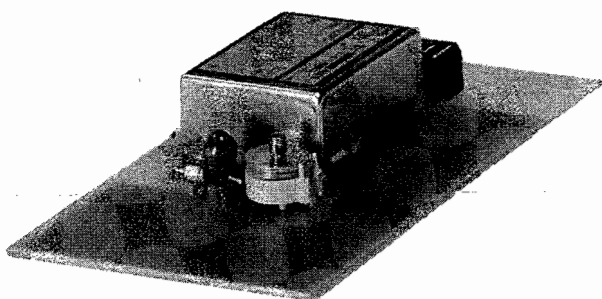
**PM 9678**

9446 096 780.1

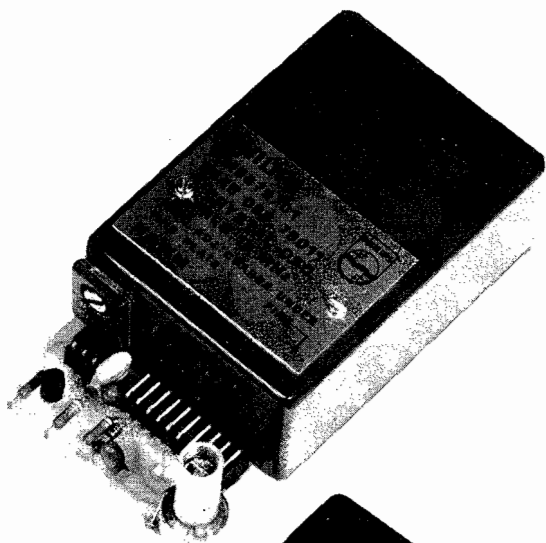
**PM 9679**

9446 096 790.1

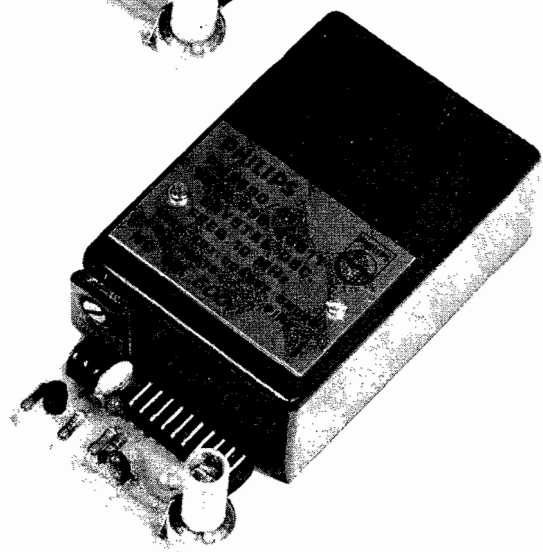
**PM 9690**

9446 096 900.1

## 1. General

The oscillators are made as plug-in cards and have a nominal frequency of 10 MHz.

## 2. Technical data

	PM 9677	PM 9678	PM 9679	PM 9690
<b>2.1. Electrical</b>				
Nominal frequency, MHz	10.000 000	10.000 000	10.000 000	10.000 000
Trimming range, Hz	$> \pm 200$	$> \pm 20$	+20*) -30	+3*) -7
Output voltage, mV (into 1 kohm)	$> 300$	$> 100$	$> 150$	$> 50$
Supply voltage, V	+ 12	+ 12	+ 11.5 to 28 (from unregulated power supply)	+ 11.5 to 28 (from unregulated power supply)
<b>Power consumption (+25°C)</b>				
Continuous operation	$< 100$ mW	$< 200$ mW	$< 100$ mA	$< 125$ mA
Stand by	none	none	$< 100$ mA	$< 125$ mA
Warm up	none	none	$< 400$ mA	$< 400$ mA
<b>Stability against:</b>				
Ageing	$< 5 \times 10^{-7}$ /month	$< 1 \times 10^{-7}$ /month**)	$< 1 \times 10^{-7}$ /month	$< 1.5 \times 10^{-9}$ /24 h (after 72 hours of continuous operation)
Temperature 0... 50°C (ref. to +25°C)	$< 1 \times 10^{-5}$	$< 1 \times 10^{-6}$	$< 1 \times 10^{-7}$	$< 3 \times 10^{-8}$
Line voltage $\pm 10$ %	$< 1 \times 10^{-8}$	$< 1 \times 10^{-9}$	$< 1 \times 10^{-9}$	$< 5 \times 10^{-10}$
Change of measuring mode and change between line, ext. and int. battery	$< 3 \times 10^{-7}$	$< 5 \times 10^{-8}$	$< 1 \times 10^{-8}$	$< 3 \times 10^{-9}$
Warm up time (to reach $1 \times 10^{-7}$ )			$< 10$ min	$< 15$ min
<b>2.2. Environmental</b>				
<b>Temperature</b>				
Storage, °C	-40 to +70	-40 to +70	-40 to +70	-40 to +70
Operating, °C	0 to +50	0 to +50	0 to +50	0 to +50
<b>Altitude</b>				
Storage, m	15000	15000	15000	15000
Operating, m	5000	5000	5000	5000
<b>Humidity at 50°C</b>				
	10—90 % RH (26° dew point)	10—90 % RH (26° dew point)	10—90 % RH (26° dew point)	10—90 % (26° dew point)
Shock	Meets the requirement of the IEC Eb recommendations			
Vibration	Meets the requirement of the IEC 68F recommendations			
} all oscillators				
<b>2.3. Mechanical</b>				
Dimensions, mm	93×50×20	93×50×15	100×52×35	100×52×35
Weight, g	50	25	100	100

\*) The indicated values regard only the fine trimming range. A coarse trimmer is available on the PM 9679 and PM 9690 to adjust for an ageing of more than 10 years.

\*\*\*) Trimming range will cover at least 10 years of operation since the ageing will decrease substantially after the first 6 months.

### 3. Frequency adjustment PM 9677

- 3.1. This adjustment requires a reference oscillator having an accuracy of  $\leq 1 \times 10^{-6}$ . The oven enclosed PHILIPS oscillators PM 9680\*, PM 9681\* and PM 9690\* meet this requirement. The adjustment should preferably be made at an ambient temperature of  $+25^{\circ}\text{C}$ .
- 3.2. Remove the bottom cover of the counter.
- 3.3. Connect the reference signal available at socket 10 MHz OUT of the external counter to INPUT A of the counter to be adjusted.
- 3.4. Set the controls of the counter to be adjusted:  
FUNCTION SELECTOR: FREQUENCY A 1 Hz  
TRIGGER LEVEL A: pulled
- 3.5. Adjust trimming capacitor C 1 to 10000.000 kHz plus or minus 10 Hz.

### 4. Frequency adjustment PM 9678

- 4.1. This adjustment requires a reference oscillator having an accuracy of  $\leq 1 \times 10^{-7}$ . The oven enclosed PHILIPS oscillator PM 9680\*, PM 9681\* and PM 9690\* meet this requirement. The adjustment should preferably be made at an ambient temperature of  $+25^{\circ}\text{C}$ .
- 4.2. Remove the bottom cover of the counter.
- 4.3. Connect the reference signal available at socket 10 MHz OUT of the external counter to INPUT A of the counter to be adjusted.
- 4.4. Set the controls of the counter to be adjusted:  
FUNCTION SELECTOR: FREQUENCY A 1 Hz  
TRIGGER LEVEL: pulled
- 4.5. Adjust trimming capacitor C 1 to 10000.000 kHz plus or minus 1 Hz.
- 4.6. Set FUNCTION SELECTOR to position 0.1 Hz and check that display read out is the same as before. If not, adjust C1 slightly to correct frequency.

### 5. Frequency adjustment PM 9679

- 5.1. This adjustment requires a reference oscillator having an accuracy of  $\leq 3 \times 10^{-8}$ . The oven enclosed PHILIPS oscillators PM 9680\*, PM 9681\* and PM 9690\* meet this requirement. The adjustment should preferably be made at an ambient temperature of  $25^{\circ}\text{C}$  and the oscillator must have been operating continuously 72 h before any adjustment is made.
- 5.2. Remove the bottom cover of the counter.
- 5.3. Connect the reference signal available at socket 10 MHz OUT of the external counter to socket EXT. TRIGG of oscilloscope PHILIPS PM 3250 or PM 3400.
- 5.4. Connect the oscillator signal available at socket 10 MHz OUT of the counter to be adjusted to INPUT A of the oscilloscope.
- 5.5. Set oscilloscope to 100 ns/div and adjust trimming potentiometer R 208 until waveform moves with a velocity of maximum 1 div./3 s (0.3 Hz). If the adjustment range of R 208 is too narrow perform the following steps 5.6 to 5.12.
- 5.6. Set trimming potentiometer R 208 to fully clockwise position.
- 5.7. Remove the two screws fixing the oscillator's text plate to the box.
- 5.8. Remove the small plastic cylinder beneath the text plate using a pair of tweezers.
- 5.9. Connect an external counter to socket 10 MHz OUT at the rear panel of the counter to be adjusted.
- 5.10. Adjust trimming capacitor C 108 until the display

- read out of the external counter is 10000020 Hz.
- 5.11. Refit the plastic cylinder and the text plate.
- 5.12. Perform steps 5.3 to 5.5.

### 6. Frequency adjustment PM 9690

- 6.1. This adjustment requires a reference frequency having an accuracy of  $\leq 1 \times 10^{-9}$ . Hewlett-Packard quartz frequency standard HP 105\* meets this requirement. The adjustment should preferably be made at an ambient temperature of  $25^{\circ}\text{C}$  and the oscillator must have been operating continuously 72 h before any adjustment is made.
- 6.2. Remove the bottom cover of the counter.
- 6.3. Connect any of the three reference signals available at sockets 5 MHz, 1 MHz and 100 kHz of the HP 105 to socket EXT. TRIGG of oscilloscope PHILIPS PM 3250 or PM 3400.
- 6.4. Connect the oscillator signal available at socket 10 MHz OUT of the counter to be adjusted to INPUT A of the oscilloscope.
- 6.5. Set oscilloscope to 100 ns/div and adjust trimming potentiometer R 208 until waveform moves with a velocity of maximum 1 div/10 s (0.1 Hz). If the adjustment range of R 208 is too narrow perform the following steps 6.6 to 6.12.
- 6.6. Set trimming potentiometer R 208 to fully clockwise position.
- 6.7. Remove the two screws fixing the oscillator's text plate to the box.
- 6.8. Remove the small plastic cylinder beneath the text plate using a pair of tweezers.
- 6.9. Connect an external counter to socket 10 MHz OUT at the rear panel of the counter to be adjusted.
- 6.10. Adjust trimming capacitor C 108 until the display read out of the external counter is 10000003 Hz.
- 6.11. Refit the plastic cylinder and the text plate.
- 6.12. Perform steps 6.3 to 6.5.

### 7. Repair of oscillator PM 9679 and PM 9690

- 7.1. Repair of these oscillators may not be carried out by the local service organisations. In case of breakdown the complete sealed oscillator box has to be sent to the factory for repair.

Factory address:

PHILIPS ELEKTRONIKINDUSTRIER AB  
INDUSTRIAL OPERATIONS  
FAK  
S-175 20 JÄRFÄLLA  
SWEDEN

### 8. Pin configuration

	PM 9677	PM 9678	PM 9679	PM 9690
Pin				
1	⊥	⊥	⊥	⊥
2	⊥	⊥	⊥	⊥
3	⊥	⊥	⊥	⊥
4			+ 11.5 to 28 V	
5	10 MHz out	10 MHz out	10 MHz out	10 MHz out
7	+ 12 V	+ 12 V		

\*To be checked against a frequency standard such as Droitwich or HBG.

9. Circuit diagram, component lay-out and spare parts list PM 9677

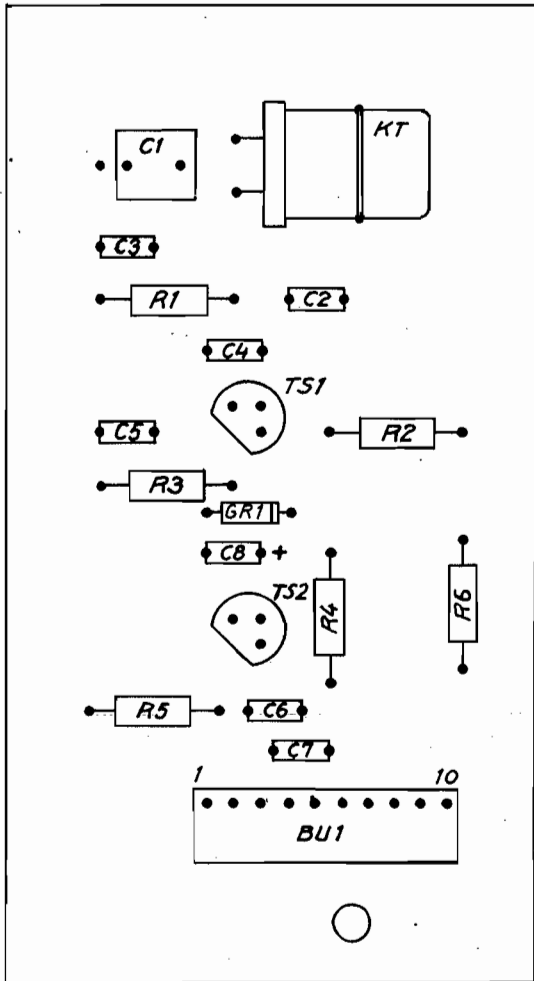

4822	110	63161
4822	110	63116
4822	110	63107
4822	110	63107
4822	110	63107
4822	110	63107

5322	125	54029
4822	122	31063
4822	122	31072
4822	122	31076
5322	122	34041
5322	122	34041
5322	122	34041
5322	124	14036

5322	130	44418
5322	130	44418
5322	130	30766

5322	242	74036
5322	267	64031

Spare parts PM 9677

RESISTORS

100K	5	CR25	R1
2.2K	5	CR25	R2
1K	5	CR25	R3
1K	5	CR25	R4
1K	5	CR25	R5
1K	5	CR25	R6

CAPACITORS

2-18P		300	C1
22P	2	100	C2
47P	2	100	C3
68P	2	100	C4
10N	=20+50	100	C5
10N	=20+50	100	C6
10N	=20+50	100	C7
15M	=10+50	16	C8

SEMI CONDUCTORS

BF 256 A	TS1
BF 256 A	TS2
BZX79-C6V2	GR1

MISCELLANEOUS

CRYSTAL 10MHZ	
CONNECTOR	BU1

Figure VIII-1. Component lay-out PM 9677

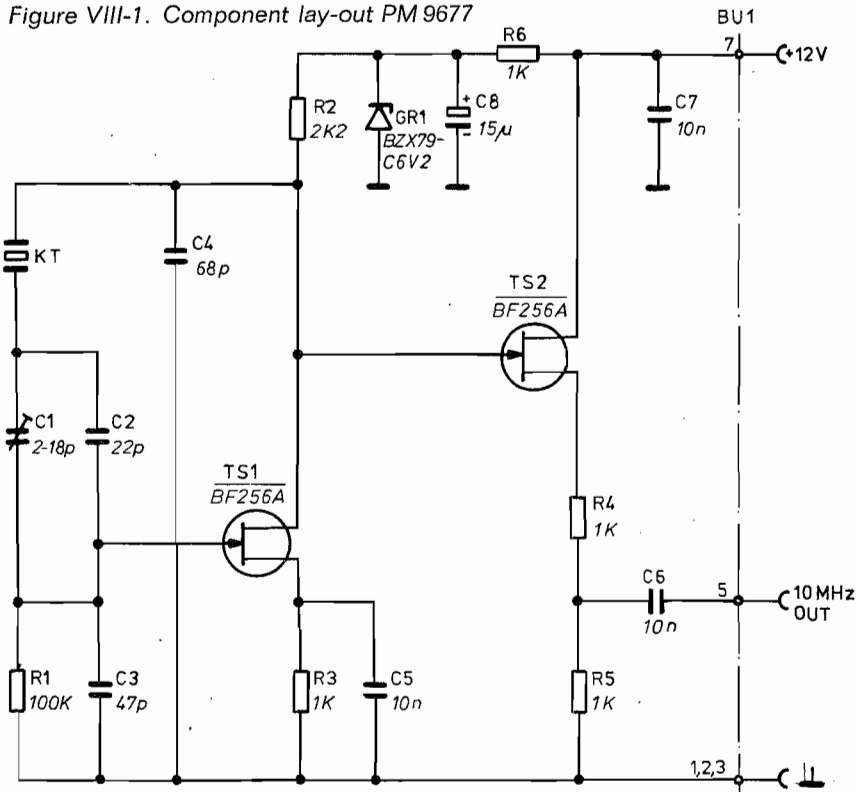

Figure VIII-2. Circuit diagram PM 9677

## 10. Circuit diagram, component lay-out and spare parts list PM 9678

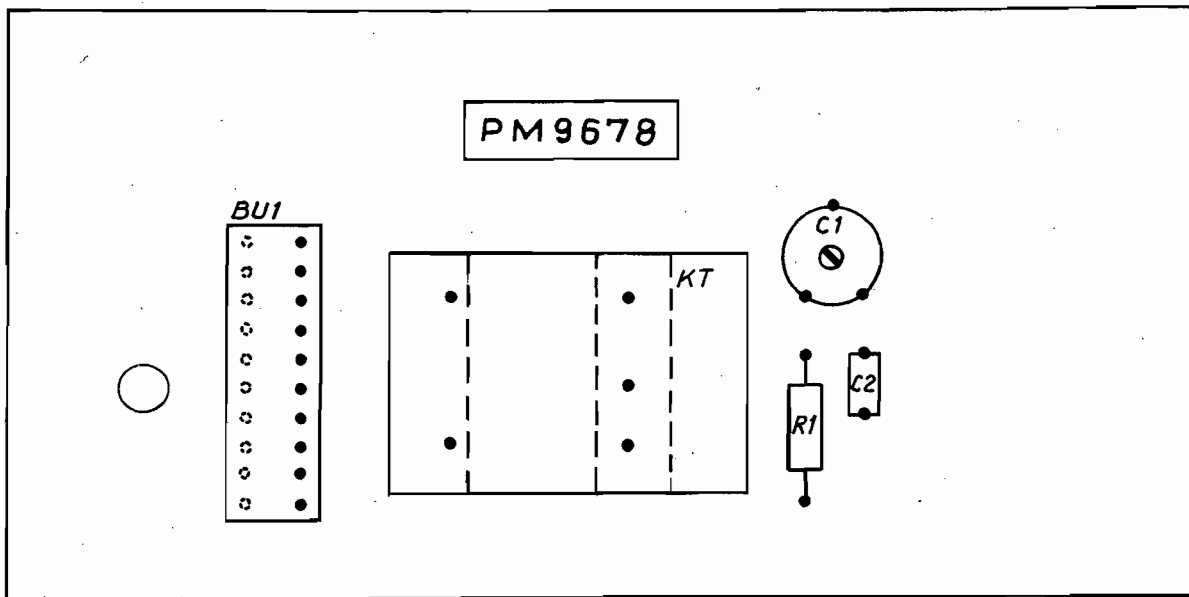

Figure VIII-3. Component lay-out PM 9678

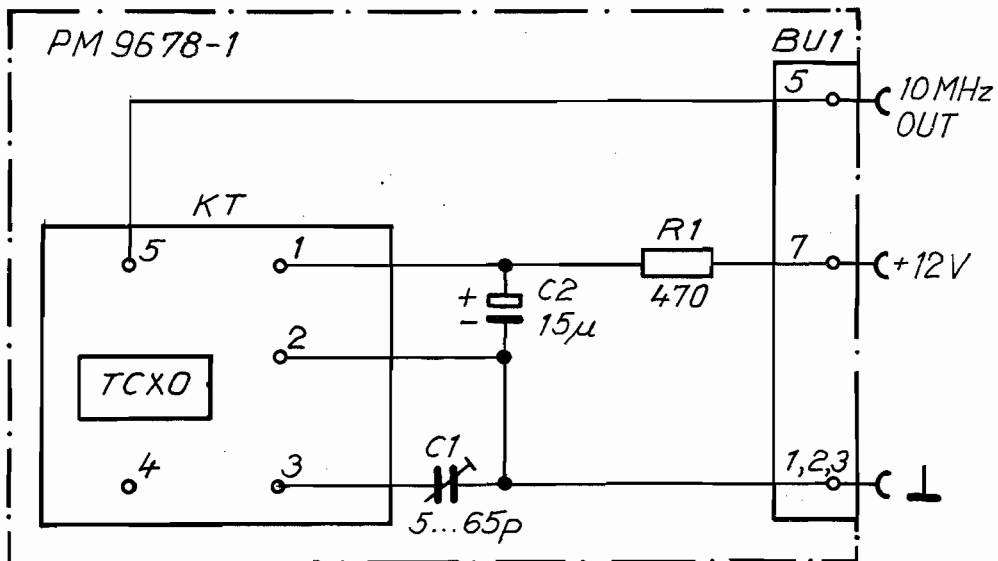

Figure VIII-4. Circuit diagram PM 9678

**ORDERING NUMBER**

4822 110 63098	470 $\Omega$ 5 %	R 1
5322 125 50057	5-65 P 100 V	C 1
5322 124 14036	15 M -10 +50 % 16 V	C 2
5322 267 64031	Connector	BU 1
5322 216 94047	Crystal 10 MHz	

Spare parts PM 9678

## IX. REPLACING PARTS

### 1. Push-button switches

1.1. Loosen switch by bending the four tags securing the switch to the switch bracket.

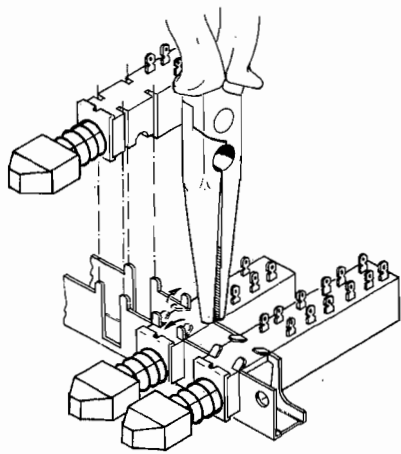

Fig. IX-1. Replacing push-button switch

1.2. Crush the switch by means of a pair of cutting pliers.

1.3. Unsolder the contact pins from the circuit board one by one. Use a sucking device to remove all tin solder from the contact holes in the circuit board before attaching the new switch.

### 2. Text plate and front rim

2.1. Remove the knobs for DISPLAY TIME, HOLD OFF (PM 6622), TRIGGER LEVEL and function selector.

2.2. Put a screw driver between the front rim and the front frame at points A.

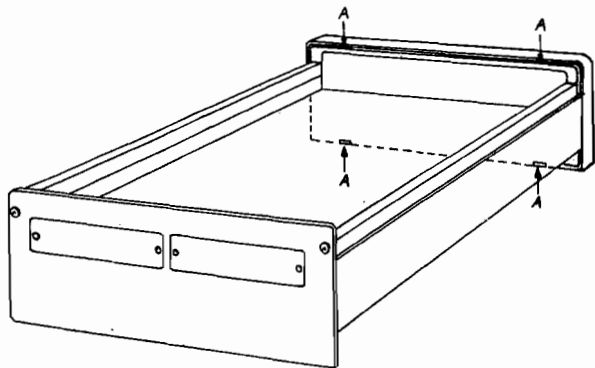

Fig. IX-2. Removing the front rim

2.3. Pry gently until front rim comes off.

2.4. Remove the text plate.

### 3. Handle

3.1. Remove the two plastic caps using a tiny screw driver or a pair of pliers.

3.2. Unscrew the two screws and pull out handle.

3.3. Before assembling grease, the tooth washer screwhole and teeth of the handle *very slightly* with vaseline.

### 4. Power supply

When replacing parts in the power supply, in particular IC150, always check the +5,0 V supply.

Proceed as follows:

4.1. Connect a voltmeter to BU107 pin +5,2 V and check that the voltage is 4.8—5.2 V

If the measured voltage does not reach 4.8—5.2 V unsolder R 1103 and select a resistor value that gives the desired voltage. The value of this resistor may be 1 k $\Omega$  to 33 k $\Omega$ . Typical value is 8 k $\Omega$ .

4.2. Check the d.c. voltages, refer to chapter VII section 3.

# X. SPARE PARTS. CIRCUIT DESCRIPTION OF POWER SUPPLY AND PRESCALER UNITS, TEST CONDITIONS AND CIRCUIT DIAGRAMS

UNIT U1 ALL MODELS  
FIXED RESISTORS

Ordering number	Ohm	Tol(%)	Type	Item
4822 110 63214	10M	10	CR25	R1003
4822 110 63189	1.2M	10	CR25	R1004
4822 110 63189	1.2M	10	CR25	R1005
4822 110 63154	56	5	CR25	R1006
5322 116 54984	68	5	PR37	R1007
4822 110 63165	150K	5	CR25	R1008
4822 110 63134	10K	5	CR25	R1009
4822 110 63134	10K	5	CR25	R1010
4822 110 63081	100	5	CR25	R1011
4822 110 60006	390	5	CR25	R1012
4822 110 63094	330	5	CR25	R1013
4822 110 63116	2.2K	5	CR25	R1017
4822 110 63092	270	5	CR25	R1018
4822 110 63087	180	5	CR25	R1019
4822 110 63107	1.0K	5	CR25	R1020
4822 110 63098	470	5	CR25	R1021
4822 110 63098	470	5	CR25	R1022
4822 110 63134	10K	5	CR25	R1023
4822 110 63109	1.2K	5	CR25	R1024
4822 110 63089	220	5	CR25	R1025
4822 110 63132	8.2K	5	CR25	R1026
4822 110 63098	470	5	CR25	R1028
4822 110 63098	470	5	CR25	R1029
4822 110 63121	3.3K	5	CR25	R1030
4822 110 63214	10M	10	CR25	R1033
4822 110 63189	1.2M	10	CR25	R1034
4822 110 63189	1.2M	10	CR25	R1035
4822 110 63154	56	5	CR25	R1036
5322 116 54984	68	5	PR37	R1037
4822 110 63165	150K	5	CR25	R1038
4822 110 63134	10K	5	CR25	R1039
4822 110 63134	10K	5	CR25	R1040
4822 110 63081	100	5	CR25	R1041
4822 110 60006	390	5	CR25	R1042
4822 110 63094	330	5	CR25	R1043
4822 110 63116	2.2K	5	CR25	R1047
4822 110 63092	270	5	CR25	R1048
4822 110 63087	180	5	CR25	R1049
4822 110 63105	820	5	CR25	R1050
4822 110 63098	470	5	CR25	R1051
4822 110 63098	470	5	CR25	R1052
4822 110 63134	10K	5	CR25	R1053
4822 110 63134	10K	5	CR25	R1054
4822 110 63089	220	5	CR25	R1055
4822 110 63098	470	5	CR25	R1058
4822 110 63098	470	5	CR25	R1059
4822 110 63121	3.3K	5	CR25	R1060
5322 116 50524	3.01K	1	MR25	R1101
5322 116 54011	5.62K	1	MR25	R1102
SELECTED*				
4822 110 63107	1.0K	5	CR25	R1103
4822 110 63121	3.3K	5	CR25	R1104
4822 110 63107	1.0K	5	CR25	R1105
4822 110 63107	1.0K	5	CR25	R1106
4822 110 63109	1.2K	5	CR25	R1108
4822 110 63116	2.2K	5	CR25	R1109
4822 110 63169	220K	5	CR25	R1110
4822 110 63089	220	5	CR25	R1111
4822 110 63063	22	5	CR25	R1112
4822 110 63089	220	5	CR25	R1113
4822 110 63032	1.5	5	CR25	R1114
5322 116 54963	0.18	10		R1115
4822 110 63098	470	5	CR25	R1116
4822 110 63089	220	5	CR25	R1117
4822 110 63072	47	5	CR25	R1118
4822 110 63169	220	5	CR25	R1119
4822 110 63107	1.0K	5	CR25	R1120
4822 110 63098	470	5	CR25	R1121
4822 110 63081	100	5	CR25	R1122
4822 116 30114	4.7K	NTC	NTC	R1123
4822 113 60084	1.0	10		R1124
4822 110 63134	10K	5	CR25	R1127
4822 110 63107	1.0	5	CR25	R1128
4822 110 63107	1.0	5	CR25	R1129
4822 110 63107	1.0	5	CR25	R1130
4822 110 63163	120K	5	CR25	R1131

4822 110 63152	47K	5	CR25	R1132
4822 110 63089	220	5	CR25	R1133
4822 110 63098	470	5	CR25	R1134
4822 110 63098	470	5	CR25	R1135
4822 110 63098	470	5	CR25	R1136
4822 110 63098	470	5	CR25	R1137
4822 110 63152	47K	5	CR25	R1138
4822 110 63125	4.7K	5	CR25	R1139
4822 110 63107	1.0	5	CR25	R1140
4822 110 63107	1.0	5	CR25	R1141
4822 110 63134	10K	5	CR25	R1142
4822 110 63152	47K	5	CR25	R1143
4822 110 63152	47K	5	CR25	R1144
4822 110 63152	47K	5	CR25	R1145
4822 110 63152	47K	5	CR25	R1146
4822 110 63134	10K	5	CR25	R1147
4822 110 63107	1.0	5	CR25	R1150
4822 110 63107	1.0	5	CR25	R1151
4822 110 60006	390	5	CR25	R1152
4822 110 63214	10M	10	CR25	R1153
4822 110 63143	22K	5	CR25	R1154
4822 110 63123	3.9K	5	CR25	R1156
4822 110 63107	1.0	5	CR25	R1157
4822 110 63089	220	5	CR25	R1158
4822 110 63134	10K	5	CR25	R1160
4822 110 63134	10K	5	CR25	R1161
4822 110 63187	1M	5	CR25	R1162
4822 110 63134	10K	5	CR25	R1163
4822 110 63107	1.0	5	CR25	R1164
4822 110 63125	4.7K	5	CR25	R1166
4822 110 63114	1.8K	5	CR25	R1167
4822 110 63114	1.8K	5	CR25	R1168
4822 110 63185	820K	5	CR25	R1170
4822 110 63098	470	5	CR25	R1171
4822 110 63098	470	5	CR25	R1172
4822 110 63114	1.8K	5	CR25	R1173
4822 110 63114	1.8K	5	CR25	R1174
4822 110 63116	2.2K	5	CR25	R1175
4822 110 63125	4.7K	5	CR25	R1176
4822 110 63143	22K	5	CR25	R1177
4822 110 63129	6.8K	5	CR25	R1178
4822 110 63138	15K	5	CR25	R1180
4822 110 63138	15K	5	CR25	R1181
4822 110 63138	15K	5	CR25	R1182
4822 110 63138	15K	5	CR25	R1183
4822 110 63138	15K	5	CR25	R1184
4822 110 63138	15K	5	CR25	R1185
4822 110 63138	15K	5	CR25	R1186
4822 110 63138	15K	5	CR25	R1187
4822 110 63138	15K	5	CR25	R1188
4822 110 63098	470	5	CR25	R1189
4822 110 63116	2.2K	5	CR25	R1190
4822 110 63116	2.2K	5	CR25	R1191
4822 110 63116	2.2K	5	CR25	R1192
4822 110 63116	2.2K	5	CR25	R1193
4822 110 63116	2.2K	5	CR25	R1194
4822 110 63116	2.2K	5	CR25	R1195
4822 110 63116	2.2K	5	CR25	R1196
4822 110 63116	2.2K	5	CR25	R1197

UNIT U1 ALL MODELS  
VARIABLE RESISTORS

Ordering number	Ohm	Description	Item
5322 101 14011	100	TRIMM	POTM R1014
5322 101 64017	47K	SK109	R1015
5322 101 14011	100	TRIMM	POTM R1044
5322 101 64017	47K	SK119	R1045
5322 101 94007	1M	SK101	SK102 R1165



UNIT U1 ALL MODELS  
 FIXED CAPACITORS

Ordering number	Farad	Tol.(%)	Volts	Item
4822 121 40407	22N	10	630	C101
4822 122 31076	68P	2	100	C103
4822 122 31168	270P	2	500	C104
4822 122 31072	47P	2	100	C105
5322 122 34041	10N	-20+50	100	C106
5322 121 40323	100N	10	100	C107
5322 124 14053	33M	-10+50	10	C108
4822 121 40407	22N	10	630	C111
4822 122 31076	68P	2	100	C113
4822 122 31168	270P	2	500	C114
4822 122 31072	47P	2	100	C115
5322 122 34041	10N	-20+50	100	C116
5322 121 40323	100N	10	100	C117
5322 124 14053	33M	-10+50	100	C118
4822 122 31081	100P	2	100	C119
5322 124 14053	33M	-10+50	10	C121
5322 122 34041	10N	-20+50	100	C122
5322 124 14053	33M	-10+50	10	C123
5322 122 34041	10N	-20+50	100	C124
5322 122 34041	10N	-20+50	100	C125
5322 122 34041	10N	-20+50	100	C126
5322 122 34041	10N	-20+50	100	C127
5322 122 34041	10N	-20+50	100	C128
5322 122 34041	10N	-20+50	100	C129
4822 121 40407	22N	10	630	C130
4822 122 31036	2.2P	2	100	C131
5322 122 34041	10N	-20+50	100	C132
5322 124 14053	33M	-10+50	10	C133
5322 122 34041	10N	-20+50	100	C134
5322 122 34041	10N	-20+50	100	C136
5322 122 34041	10N	-20+50	100	C137
4822 124 10197	47M	-10+50	6.3	C139
4822 124 10197	47M	-10+50	6.3	C140
4822 121 40232	220N	10	100	C141
5322 122 34041	10N	-20+50	100	C144
4822 122 30113	180P	2	100	C146
5322 122 34041	10N	-20+50	100	C147
5322 122 34041	10N	-20+50	100	C150
4822 122 31081	100P			C151
4822 124 20534	680M	-10+50	40	C152
4822 121 40104	150N	10	250	C153
4822 124 20586	150M	-10+50	16	C154
4822 124 20589	220M	-10+50	10	C155
4822 124 20589	220M	-10+50	10	C156
4822 124 20589	220M	-10+50	10	C157
4822 124 20499	22M	-10+50	63	C160
4822 124 20534	680M	-10+50	40	C161
5322 122 34041	10N	-20+50	100	C162
5322 124 24116	1M			C163
4822 122 31165	330P	10	100	C164
5322 124 14075	1M	-10+50	25	C165
5322 122 34041	10N	-20+50	100	C166
4822 121 40232	220N	10	100	C167
5322 124 14066	10M	-10+50	6.3	C168
5322 122 34041	10N	-20+50	100	C169
4822 122 31081	100P	2	100	C170
5322 121 40323	100N	10	100	C172
5322 121 40323	100N	10	100	C176
4822 122 30114	2.2N	10	100	C178
5322 122 34041	10N	-20+50	100	C179
4822 121 41156	68N	10	250	C180
5322 121 44137	68N	10	250	C181
5322 121 44137	68N	10	250	C182
5322 121 44137	68N	10	250	C183
5322 121 44137	68N	10	250	C184
5322 121 44137	68N	10	250	C185
5322 121 44137	68N	10	250	C186
5322 121 44137	68N	10	250	C187
5322 121 44137	68N	10	250	C188
4822 121 40104	150N	10	250	C189

 UNIT U1 ALL MODELS  
 VARIABLE CAPACITORS

Ordering number	Farad	Volts	Item
5322 125 54024	2-9P	300	C102
5322 125 54024	2-9P	300	C112

 UNIT U1 ALL MODELS  
 INTEGRATED CIRCUITS

Ordering number	Type	Item
5322 209 85408	MC1651L	1C101
5322 209 84643	MC10102P	1C102
5322 209 85409	GXB10110	1C103
5322 209 84825	MC10216P	1C104
5322 209 84183	SN74S74N	1C125
5322 209 84183	SN74S74N	1C126
5322 209 84304	SN75107AN	1C127
5322 209 85406	N74LS54A	1C128
5322 209 84628	N7403A	1C129
5322 209 84528	SN7400N	1C130
5322 209 84722	GZF1201P MOS	1C131
5322 209 84722	GZF1201P MOS	1C132
5322 209 85001	SN74LS157N	1C133
5322 209 84996	SN74LS10N	1C134
5322 209 84183	SN74LS74N	1C135
5322 209 84724	SN74S64N	1C136
5322 209 85407	N74S02A	1C137
5322 209 84655	723PC	1C150
5322 209 85085	F34049PC SELECTED	1C151
5322 209 84983	SN74LS00N	1C152
5322 209 85412	CD4093BE MOS	1C153
5322 209 84983	SN74LS00N	1C154
5322 209 84993	SN74LS02N	1C155
5322 209 84993	SN74LS02N	1C156
5322 209 84976	F34001PC	1C157
5322 209 84983	SN74LS00N	1C158
5322 209 84984	SN74LS04N	1C159
5322 209 85411	82S90A	1C174
5322 209 80059	SN7475N	1C175
5322 209 84529	SN7403N	1C176
5322 209 84722	GZF1201P MOS	1C177
5322 209 84722	GZF1201P MOS	1C178
5322 209 80072	SN7490AN	1C179
5322 209 80142	SN7442AN	1C180
5322 209 84723	DM8884AN	1C181
5322 111 94015	6X1.0K	1C190
5322 111 94015	6X1.0K	1C191
5322 111 94031	6X47K	1C192
5322 111 94031	6X47K	1C193
5322 111 94012	6X6.8K	1C194
5322 111 94012	6X6.8K	1C195
5322 111 94031	6X47K	1C196
5322 111 94012	6X6.8K	1C197
5322 111 94026	6X470K	1C198

 UNIT U1 ALL MODELS  
 TRANSISTORS

Ordering number	Type	Item
5322 130 44578	E411 SILICONIX	TS101
5322 130 44578	E411 SILICONIX	TS102
5322 130 44435	2N5770	TS103
5322 130 44435	2N5770	TS104
5322 130 44197	BC558B	TS105
5322 130 44197	BC558B	TS106
5322 130 40407	2N2369	TS142
4822 130 40855	BC337	TS146
5322 130 24035	BT100A-02	TS150
5322 130 40482	BRY39	TS151

4822	130	40855	BC337	TS152
5322	130	44417	BDX35	TS153
5322	130	40482	BRY39	TS154
5322	130	44418	BF256A	TS155
4822	130	40937	BC548B	TS156
5322	130	44256	BC557	TS177
5322	130	44247	BSS68	TS180
5322	130	44247	BSS68	TS181
5322	130	44247	BSS68	TS182
5322	130	44247	BSS68	TS183
5322	130	44247	BSS68	TS184
5322	130	44247	BSS68	TS185
5322	130	44247	BSS68	TS186
5322	130	44247	BSS68	TS187
5322	130	44247	BSS68	TS188

## UNIT U1 ALL MODELS

## DIODES

Ordering number	Type	Item
5322	130 30392	BZY88-C3V3 GR101
5322	130 30613	BAW62 GR102
5322	130 30613	BAW62 GR103
5322	130 30392	BZY88-C3V3 GR104
5322	130 34563	BZX79-C2V7 GR105
5322	130 30613	BAW62 GR106
5322	130 34563	BZX79-C2V7 GR107
5322	130 30613	BAW62 GR108
5322	130 30392	BZY88-C3V3 GR111
5322	130 30613	BAW62 GR112
5322	130 30613	BAW62 GR113
5322	130 30392	BZY-C3V3 GR114
5322	130 34563	BZX79-C2V7 GR115
5322	130 30613	BAW62 GR116
5322	130 34563	BZX79-C2V7 GR117
5322	130 30613	BAW62 GR118
5322	130 30613	BAW62 GR121
5322	130 34047	BZX75-C1V4 GR122
5322	130 30613	BAW62 GR125
5322	130 30613	BAW62 GR138
5322	130 30613	BAW62 GR139
5322	130 30613	BAW62 GR140
5322	130 30613	BAW62 GR141
5322	130 30613	BAW62 GR142
5322	130 30613	BAW62 GR143
5322	130 30613	BAW62 GR144
5322	130 30613	BAW62 GR145
5322	130 30774	BZX79-C10 GR151
5322	130 30594	BAV10 GR152
5322	130 34401	BZX70-C56 GR153
5322	130 30392	BZY88-C3V3 GR154
4822	130 30868	BY210-600 GR155
4822	130 30868	BY210-400 GR156
4822	130 30868	BY210-400 GR157
4822	130 30868	BY210-400 GR158
4822	130 30868	BY210-400 GR159
5322	130 30759	BZX79-C5V6 GR160
4822	130 30868	BY210-400 GR161
5322	130 30192	BY126 GR163
5322	130 30414	BY164 GR167
5322	130 30613	BAW62 GR170
5322	130 34049	BZX75-C2V1 GR171
5322	130 30613	BAW62 GR172
5322	130 30613	BAW62 GR173
5322	130 30613	BAW62 GR175
5322	130 34189	BAW20 GR180
5322	130 34189	BAW20 GR181
5322	130 34189	BAW20 GR182
5322	130 34189	BAW20 GR183
5322	130 34189	BAW20 GR184
5322	130 34189	BAW20 GR185
5322	130 34189	BAW20 GR186
5322	130 34189	BAW20 GR187
5322	130 34189	BAW20 GR188
5322	130 34166	BZX79-C51 GR189

## UNIT U1 ALL MODELS

## INDUCTANCES

Ordering number	Description	Item	Qty.
5322	158 10289	INDUCTANCE 0.68MH	L101 1
5322	158 10289	INDUCTANCE 0.68MH	L102 1
5322	158 10243	INDUCTANCE 100MH	L103 1
5322	158 10284	INDUCTANCE 47MH	L104 1
5322	158 10284	INDUCTANCE 47MH	L105 1
5322	158 10052	CHOKE	L150 1
4822	526 10097	FXC BEAD	L151 1
5322	158 10052	CHOKE	L152 1

## UNIT U1 ALL MODELS

## MECHANICAL PARTS

Ordering number	Description	Item	Qty.
5322	256 34031	FUSEHOLDER	VL150 2
5322	255 44107	IC HOLDER 16 PINS	D.I.L 2
5322	255 44112	IC HOLDER 18 PINS	D.I.L 5
5322	255 40089	TRANSISTOR HOLDER	TO 18-3 11
5322	255 40089	TRANSISTOR HOLDER	TO 18-4 2
5322	265 54006	TRANSISTOR HOLDER	TS153 1
5322	265 54006	FEMALE CONNECTOR	BU 102 1
5322	265 54018	MALE CONNECTOR	BU 102 1
5322	265 44064	MALE CONNECTOR	BU103 1
5322	265 44064	MALE CONNECTOR	BU104 1
5322	265 44064	MALE CONNECTOR	BU105 1
5322	255 44107	FEMALE CONNECTOR	BU106 1
5322	265 54006	FEMALE CONNECTOR	BU107 1
5322	101 94007	COMBINED SWITCH	SK101 1
5322	101 94007	COMBINED SWITCH	SK102 1
5322	276 14117	PUSH BUTTON SWITCH	SK103 1
5322	276 14117	PUSH BUTTON SWITCH	SK104 1
5322	273 74008	ROTARY SWITCH	SK105 1
5322	276 14117	PUSH BUTTON SWITCH	SK106 1
5322	276 14117	PUSH BUTTON SWITCH	SK107 1
5322	276 14117	PUSH BUTTON SWITCH	SK108 1
5322	101 64017	COMBINED SWITCH	SK109 1
5322	276 14117	PUSH BUTTON SWITCH	SK110 1
5322	276 14117	PUSH BUTTON SWITCH	SK116 1
5322	276 14117	PUSH BUTTON SWITCH	SK117 1
5322	276 14117	PUSH BUTTON SWITCH	SK118 1
5322	101 64017	COMBINED SWITCH	SK119 1
5322	276 14117	PUSH BUTTON SWITCH	SK120 1
5322	277 24006	SLIDE SWITCH	SK121 1

## UNIT U1 ALL MODELS

## MISCELLANEOUS

Ordering number	Description	Item	Qty.
5322	146 14079	MAINS TRANSFORMER	T101 1
5322	142 64027	DC-DC TRANSFORMER	T102 1
4822	253 20022	FUSE 1.6A FAST	VL150 1
4822	252 20001	THERMAL FUSE	VL101 1
5322	131 94042	DISPLAY	B101 1
5322	462 34127	GUIDE RAIL	FOR U1 14

## FRONT PANEL ALL MODELS

Ordering number	Description	Item	Qty.
5322	456 14054	TEXT PLATE	PM6622 1
5322	456 14055	TEXT PLATE	PM6624 1
5322	456 14056	TEXT PLATE	PM6625 1
5322	450 64059	WINDOW	1
5322	414 34076	FUNCTION KNOB	SK105 1
5322	414 74019	COVER FUNCTION KNOB	SK105 1
5322	414 34091	DISPLAY KNOB	SK101 1
5322	414 74015	COVER DISPLAY KNOB	SK101 1
5322	414 34091	HOLD OFF KNOB	SK403 1
5322	414 74015	COVER HOLD OFF KNOB	SK403 1
5322	414 34091	TRIGGER KNOBS	2
5322	414 74015	COVER TRIGGER KNOBS	2
5322	414 14011	PUSH BUTTON KNOBS	10
5322	267 10004	INPUT SOCKETS A B	BU1 BU2 2

## REAR PANEL ALL MODELS

Ordering number	Description	Item
5322 267 34059	EXT BATTERY SOCKET	BU21
5322 267 34059	EXT BATTERY SOCKET	BU22
5322 265 30066	MAINS INPUT SOCKET	BU23
5322 267 10004	INPUT D=10MHZ OUT	BU24
5322 267 10004	EXT. RESET	BU25
5322 267 10004	GATE OPEN	BU27
5322 277 24017	INT EXT STD SWITCH	SK22
5322 121 44092	CAPACITOR 47NF 250V	C1

## CABINET ALL MODELS

Ordering number	Description	Item
5322 498 54048	HANDLE ARM	2
5322 498 54054	HANDLE PROFILE	1
5322 520 34164	BEARING BUSH	2
5322 414 64053	CAP HANDLE ARM	2
5322 447 84467	TOP COVER	1
5322 447 84466	BOTTOM COVER	1
5322 466 85335	FRONT ORNAMENT	1
5322 459 24054	REAR ORNAMENT	1
5322 462 44181	REAR FOOT	4
5322 462 44179	BOTTOM FOOT	4
4822 462 70497	PLUG BOTTOM FOOT	4

## UNIT U3 ALL MODELS

Ordering number	Description	Item
5322 321 24389	CABLE COMPLETE	U3 TO U1
5322 268 24073	TEST SOCKET	BU302
5322 268 24073	TEST SOCKET	BU303
5322 130 34562	LD35/II	GR301
5322 130 34562	LD35/II	GR302
5322 130 34562	LD35/II	GR303
5322 130 34562	LD35/II	GR304
5322 130 34562	LD35/II	GR305
5322 130 34562	LD35/II	GR306
5322 130 34562	LD35/II	GR307

## UNIT U4 ALL MODELS

Ordering number	Description	Item
5322 321 24391	CABLE COMPLETE	U4 TO U1
5322 277 24006	SLIDE SWITCH	SK401
5322 277 24006	SLIDE SWITCH	SK402
5322 101 54008	COMBINED SK403=SK404R401	
5322 121 54118	CAPACITOR 150NF 63V C401	

UNIT U2 PM6624  
FIXED RESISTORS

Ordering number	Ohm	Tol.(%)	Type	Item
4822 116 51142	150	5	PR37	R201
5322 116 54396	68	5	PR52	R202
5322 116 54396	68	5	PR52	R203
5322 116 50417	162	5	MR25	R204
4822 111 30328	330	5	CR16	R205
4822 110 63125	4.7K	5	CR25	R206
4822 110 63147	33K	5	CR25	R207
4822 110 63107	1K	5	CR25	R208
4822 110 63125	4.7K	5	CR25	R209
4822 110 63152	47K	5	CR25	R210
4822 110 63107	1K	5	CR25	R211
4822 110 63138	15K	5	CR25	R212
4822 111 30067	33	5	CR16	R213
4822 110 63134	10K	5	CR25	R214
4822 110 63141	18K	5	CR25	R215
4822 110 63101	560	5	CR25	R216
4822 111 30264	2.7K	5	CR16	R217
4822 111 30323	270	5	CR16	R218
4822 111 30272	680	5	CR16	R219
4822 111 30245	47	5	CR16	R220
4822 111 30347	10	5	CR16	R221
4822 110 63161	100K	5	CR25	R222
4822 110 63116	2.2K	5	CR25	R223
4822 110 63125	4.7K	5	CR25	R224
4822 110 63134	10K	5	CR25	R225
4822 110 63098	470	5	CR25	R226
4822 110 63116	2.2K	5	CR25	R227
4822 110 63054	10	5	CR25	R228
4822 111 30272	680	5	CR25	R229
4822 110 63098	470	5	CR25	R230
4822 110 63116	2.2K	5	CR25	R231
4822 110 63125	4.7K	5	CR25	R238

UNIT U2 PM6624  
FIXED CAPACITORS

Ordering number	Farad	Tol.(%)	Volts	Item
4822 122 31177	470P	10	100	C201
4822 122 31177	470P	10	100	C202
4822 122 31177	470P	10	100	C203
4822 122 31177	470P	10	10	C204
4822 122 30043	10N	-20+80	63	C205
5322 122 34043	47P	2	50	C206
4822 122 31175	1N	10	100	C207
5322 124 14079	68M		6.3	C208
4822 122 31043	3.9P	2	63	C209
4822 122 31173	220P	10	100	C211
4822 122 30094	220P	10	100	C212
4822 122 31177	470P	10	100	C213
4822 122 30043	10N	-20+80	63	C214
5322 124 14036	15M		16	C215
4822 122 31175	1N	10	100	C216
5322 122 34043	47P	2	100	C217
4822 122 31072	47P	10	100	C218
4822 122 30043	10N	-20+80	63	C219
4822 122 31175	1N	10	100	C220
5322 122 34043	47P	2	50	C221
4822 122 31175	1N	10	100	C222
4822 122 31175	1N	10	100	C223
5322 124 14079	68M		6.3	C224
4822 122 30043	10N	-20+80	63	C225
4822 122 31072	47P	10	100	C226
4822 122 31173	220P	10	100	C227

UNIT U2 PM6624  
INTEGRATED CIRCUITS

Ordering number	Type	Item
-----------------	------	------

5322 209 85414	QM334	IC201
5322 209 85414	DM334	IC202
5322 209 84721	SP670B	IC203
5322 209 84163	SN72741P	IC204
5322 209 84163	SN72741P	IC205
5322 209 84165	SN7474N	IC206
5322 209 84165	SN7474N	IC207

UNIT U2 PM6624  
TRANSISTORS

Ordering number	Type	Item
-----------------	------	------

4822 130 40937	BC548B	TS201
5322 130 40348	BC178B	TS202
5322 130 44179	BFR90	TS203
4822 130 40937	BC548B	TS204
5322 130 40343	BC108B	TS205

UNIT U2 PM6224  
DIODES

Ordering number	Type	Item
-----------------	------	------

5322 130 34364	BA379	GR201
5322 130 34364	BA379	GR202
5322 130 34283	HP5082-2835	GR203
5322 130 34283	HP5082-2835	GR204
5322 130 34364	BA379	GR205
5322 130 34364	BA379	GR206
5322 130 34364	BA379	GR207
5322 130 30613	BAW62	GR208
5322 130 34283	HP5082-2835	GR209
5322 130 34283	HP5082-2835	GR210
5322 130 30666	BZX79-C7V5	GR211

UNIT U2 PM6624  
INDUCTANCES

Ordering number	Description	Item
-----------------	-------------	------

5322 158 14119	COIL	L201
5322 158 14119	COIL	L202
5322 158 10276	INDUCTANCE 4.7MH	L203
5322 158 14119	COIL	L204
4822 526 10025	FXC BEAD	L205
4822 526 10025	FXC BEAD	L207
4822 526 10025	FXC BEAD	L208
4822 526 10025	FXC BEAD	L209
4822 526 10025	FXC BEAD	L210
5322 526 14019	BEAD	L211

UNIT U2 PM6624  
MECHANICAL PARTS

Ordering number	Description	Item	Qty
-----------------	-------------	------	-----

5322 265 54006	FEMALE CONNECTOR	BU201	1
5322 265 54018	MALE CONNECTOR	BU201	1
5322 535 94711	DISTANCE PIECE	FOR U2	2
5322 462 34054	GUIDE RAIL	FOR U2	2
5322 255 44122	IC HOLDER 14 PINS	DIL	1
5322 255 40089	TRANSISTOR HOLDER	TO18-3	2

UNIT U2 PM6625  
FIXED RESISTORS

Ordering number	Ohm	Tol(%)	Type	Item
-----------------	-----	--------	------	------

5322 116 54393	150	5	PR52	R201
5322 116 54396	68	5	PR52	R202
5322 116 54396	68	5	PR52	R203
5322 116 50417	162	5	MR25	R204
4822 111 30328	330	5	CR16	R205
4822 110 63125	4.7K	5	CR25	R206
4822 110 63147	33K	5	CR25	R207
4822 110 63107	1K	5	CR25	R208
4822 110 63125	4.7K	5	CR25	R209
4822 110 63152	47K	5	CR25	R210
4822 110 63107	1K	5	CR25	R211
4822 110 63138	15K	5	CR25	R212
4822 111 30348	27	5	CR16	R213
4822 110 63134	10K	5	CR25	R214
4822 110 63141	18K	5	CR25	R215
4822 110 63094	330	5	CR25	R216
4822 111 30265	2.2K	5	CR16	R217
4822 111 30331	470	5	CR16	R218
4822 111 30312	4.7K	5	CR16	R219
4822 111 30327	220	5	CR16	R220
4822 111 30347	10	5	CR16	R221
4822 110 63161	100K	5	CR25	R222
4822 110 63116	2.2K	5	CR25	R223
4822 110 63116	2.2K	5	CR25	R224
4822 110 63134	10K	5	CR25	R225
4822 110 63098	470	5	CR25	R226
4822 110 63116	2.2K	5	CR25	R227
4822 110 63054	10	5	CR25	R228
4822 111 30272	680	5	CR16	R229
4822 110 63098	470	5	CR25	R230
4822 110 63116	2.2K	5	CR25	R231
4822 111 30324	100	5	CR16	R233
4822 111 30328	330	5	CR16	R234
4822 111 30328	330	5	CR16	R235
4822 110 63098	470	5	CR16	R236
4822 110 63069	39	5	CR16	R237
4822 110 63125	4.7K	5	CR16	R238

UNIT U2 PM6625  
FIXED CAPACITORS

Ordering number	Farad	Tol.(%)	Volts	Item
-----------------	-------	---------	-------	------

5322 122 34071	470P	20	50	C201
5322 122 34071	470P	20	50	C202
5322 122 34071	470P	20	50	C203
5322 122 34071	470P	20	50	C204
4822 122 30043	10N	-20+80	63	C205
5322 122 34043	47P	10	50	C206
4822 122 31175	1N	10	100	C207
5322 124 14079	68M	-10+50	6.3	C208
5322 122 34043	47P	10	50	C209
4822 122 31173	220P	10	100	C210
4822 122 31173	220P	10	100	C211
4822 122 31173	220P	10	100	C212
5322 122 34071	470P	10	50	C213
4822 122 30043	10N	-20+80	63	C214
5322 124 14036	15M	-10+50	16	C215
4822 122 31175	1N	10	100	C216
5322 122 34071	470P	20	50	C217
5322 122 34042	12P	10	50	C218
4822 122 30043	10N	-20+80	63	C219
4822 122 31175	1N	10	100	C220
4822 122 30043	10N	-20+80	63	C221
5322 122 34043	47P	10	50	C222
5322 122 34071	470P	20	50	C223
5322 124 14079	68M	-10+50	6.3	C224
5322 122 34071	470P	10	50	C225
4822 122 31072	47P	2	100	C226
5322 122 34071	470P	20	50	C227
4822 122 31072	47P	2	100	C228
4822 122 30043	10N	-20+80	63	C229
5322 122 34043	47P	10	50	C230
4822 122 31054	10P	2	100	C231

UNIT U2 PM6625  
 INTERGRATED CIRCUITS

Ordering number	Type	Item
5322 209 85414	OM334	1C201
5322 209 85414	OM334	1C202
5322 209 84725	SP8616B	1C203
5322 209 84165	SN72741P	1C204
5322 209 84165	SN72741P	1C205
5322 209 84165	SN7474N	1C206
5322 209 84165	SN7474N	1C207
5322 209 84729	SP8600B	1C208

 UNIT U2 PM6625  
 TRANSISTORS

Ordering number	Type	Item
4822 130 40937	BC548B	TS201
5322 130 40348	BC178B	TS202
5322 130 44179	BFR90	TS203
4822 130 40937	BC548B	TS204
5322 130 40343	BC108B	TS205
5322 130 44435	2N5770	TS206

 UNIT U2 PM6625  
 DIODES

Ordering number	Type	Item
5322 130 34364	BA379	GR201
5322 130 34364	BA379	GR202
5322 130 34283	HP5082-2835	GR203
5322 130 34283	HP5082-2835	GR204
5322 130 34364	BA379	GR205
5322 130 34364	BA379	GR206
5322 130 34364	BA379	GR207
5322 130 30613	BAW62	GR208
5322 130 34283	HP5082-2835	GR209
5322 130 34283	HP5082-2835	GR210
5322 130 30666	BZX79-C7V5	GR211
5322 130 34364	BA379	GR212
5322 130 30666	BZX79-C7V5	GR213
5322 130 30411	BZX79-C3V9	GR214
5322 130 30411	BZX79-C3V9	GR215

 UNIT U2 PM6625  
 INDUCTANSES

Ordering number	Description	Item
5322 158 14119	COIL	L201
5322 158 14119	COIL	L202
5322 158 10276	INDUCTANCE 4.7MH	L203
5322 158 14119	COIL	L204
5322 158 14119	COIL	L205
5322 158 14119	COIL	L206
5322 158 14119	COIL	L207
5322 158 14119	COIL	L208
5322 157 44024	COIL	L209
4822 526 10025	FXC BEAD	L210
4822 526 10025	FXC BEAD	L211
4822 526 10025	FXC BEAD	L212
4822 526 10025	FXC BEAD	L214

 UNIT U2 PM6625  
 MECHANICAL PARTS

Ordering number	Description	Item	Qty
5322 265 54006	FEMALE CONNECTOR	BU201	1
5322 265 54018	MALE CONNECTOR	BU201	1
5322 535 94711	DISTANCE PIECE	FOR U2	2
5322 255 44122	IC HOLDER 14 PINS DIL		1
5322 255 40089	TRANSISTOR HOLDER TO18-3		2
5322 462 34054	GUIDE RAIL		2

## 5. Circuit description prescaler units and power supply

### 5.1. Prescaler PM 6624

Unit U2 contains the 520 MHz amplifier and prescaler circuits, and also two D flip-flops IC 206 and IC 207 dividing the time base signal generated on unit U1. The signal to be measured enters the input amplifier at socket BU 2. After AC coupling capacitor C 201, a resistive attenuator network R 201 . . . R 204 is incorporated which maintains the VSWR of the input and also serves as a series impedance for the PIN diode attenuator GR 201 and GR 202. Schottky diodes GR 203 and GR 204 are clipping the signal but generate also current to the PIN diodes which provide automatically the proper attenuation of high-amplitude signals.

At low amplitude the signal passes this first PIN diode attenuator unchanged to the next PIN diode attenuator GR 205 . . . GR 207. Here the amplitude is reduced further before the signal is entering the input amplifier.

After input conditioning, the measuring signal is applied to two cascade wide-band amplifiers IC 201 and IC 202. The signal level at IC 202 is detected by GR 209, GR 210 controlling the AGC amplifier IC 204 and Schmitt trigger IC 205.

When the detected level is sufficient, IC 204 starts controlling the PIN diode attenuator GR 205 . . . GR 207. Transistor TS 201 ensures a linear attenuator response within the input signal range.

Via R 213, C 213 and amplifier TS 203 the signal is fed to input 10 of divide-by-eight circuit IC 203. Output 1 provides the divided signal to the 80 MHz input amplifier, BU 201.

The detected signal from GR 209, 210 is also fed to operational amplifier IC 205 performing a Schmitt trigger function. When no measuring signal is present or at a low detected level, output IC 205:6 is positive. TS 204 is then turned on, shorts the output line to earth.

When the detected signal from GR 209, 210 has reached a sufficient level, IC 205:6 goes LOW and TS 204 is turned off.

TS 202 is controlled by switch SK 401. When the switch is set to position INPUT A the level at BU 201:5 PRESCALER, goes HIGH which turns TS 202 off. Via R 230 and GR 211, also TS 205 is switched off. No supply voltage for the amplifier is present until switch SK 401 is set to position INPUT C and BU 201:5 goes LOW.

The two D flip-flops of IC 206 and one D flip-flop of IC 207 provide the division by 8 of the time base frequency TB 1.

### 5.2. Prescaler PM 6625

The input conditioning section of the 1 GHz amplifier up to IC 201 and the AGC and Schmitt trigger circuits are principally the same as in the 520 MHz amplifier of PM 6624. Refer to that description.

After input conditioning, the measuring signal is applied to two cascade wide-band amplifiers IC 201 and IC 202. The signal level at IC 202:7 is detected by GR 209, GR 210 controlling the AGC amplifier IC 204 and Schmitt trigger IC 205.

Via R 213, C 213 and amplifier TS 203, the signal is fed to input 4 of divide-by-four circuit IC 203. The complementary outputs 10 and 11 of this circuit provide the signal to the next 4-divider IC 208 via zeners GR 214, GR 215. These diodes are interfacing the +1 V output of IC 203 with the -3 V input requirement of IC 208. The measuring signal frequency now divided by 16, is fed via TS 206 to the output line BU 201:1 which is connected with BU 102:1 to the 80 MHz input amplifier.

TS 202 is controlled by switch SK 401. When the switch is set to position INPUT A the level at BU 201:5, PRESCALER, goes HIGH which turns TS 202 off. Via R 230 and GR 211 also TS 205 is switched off. No supply voltage for the amplifier is present until SK 401 is set to position INPUT C and BU 201:5 goes LOW.

The four D flip-flops of IC 206 and IC 207 provide the division by 16 of the time base frequency TB 1.

### 5.3. Power supply

The power supply operates from 115 V AC or 230 V AC 50 to 400 Hz or from the internal battery PM 9673 or from an external battery with an output voltage of 12 to 28 V. It provides five stabilised and overload-protected voltages of +120 V, +12 V, +5 V, -5 V and -50 V.

The power supply may be divided into the *power input circuit* mainly consisting of the mains transformer T 101 and rectifier GR 167, the *over-voltage protection circuit* mainly consisting of thyristors TS 150, TS 151 and zener diode GR 160, the *voltage regulation circuit* mainly consisting of voltage regulator IC 150, thyristor TS 154, the *DC-to-DC converter* mainly consisting of primary side of transformer T 102, driver TS 152 and switch TS 153.

#### *Power input circuit*

When the power supply operates from the *mains*, the 115 V AC or 230 V AC is transformed to 20 V AC by transformer T 101, rectified in the diode-bridge GR 167, filtered by C 152 and C 161 and fed to the power supply circuits via switch SK 121 and SK 102.

When the power supply operates from an *external battery* the current to the power supply circuits is fed from BU 21 at the rear panel via protecting diode GR 164 and switches SK 121 and SK 102.

When the internal battery is used the current is fed from pin 8 of BU 105 via SK 121 and SK 102 to the power supply circuits.

Over-voltage protection

The over-voltage protection circuit consists mainly of thyristors TS 150, TS 151 and zener diode GR 160.

The anode of GR 160 is connected to the +5 V output from the power supply. If this voltage increases to 5.6 V... 5.8 V, the zener diode GR 160 will start to conduct and a current will flow through resistor R 1121. The voltage drop across R 1121 is fed to the gate of thyristor TS 151 via resistor R 1120. The anode is connected to the +5 V output voltage via resistor R 1118.

The thyristor will switch on and a voltage drop arises across resistor R 1122. This voltage is fed to the gate of thyristor TS 150, whose anode is connected to the d.c. input voltage. The thyristor will switch on and blow fuse VL 150, or, if the counter is operating in the internal battery mode, fuse VL 1 in the battery unit PM 9673. The capacitor across the gate and cathode of thyristor TS 151 prevents transients from the mains to blow fuse VL 150 accidentally.

DC to DC converter

The DC to DC converter is basically a blocking oscillator consisting mainly of switch transistor TS 153 and terminals 4—9 of the transformer T 102. When switch SK 102 is set to position ON, the DC voltage from the power input circuit is fed to the transistor TS 155 which works as a constant current source of approximately 1 mA ( $I_1$ ).

The current  $I_1$  will cause switch transistor TS 153 to start conducting and the linearly increasing current  $I_2$  to flow.

This current  $I_2$  will cause a voltage across terminals 3—8 of the transformer and the current  $I_3$  will start to flow.

This will cause drive transistor TS 152 to saturate switch transistor TS 153. When the transistor no longer can saturate, current  $I_3$  will stop to increase and the induced voltage at terminal 3 of transformer T 102 will disappear.

This will cause TS 153 to switch off and the collector voltage to rise to the same level as the supply voltage. At this moment the magnetic flux will discharge through the secondary windings of T 102 and diodes GR 155—159.

Output voltage regulation circuit

The output voltage regulation circuit consists mainly of voltage regulator IC 150 and thyristor TS 154.

The purpose of the thyristor TS 154 is to switch off the drive transistor TS 152 in order to regulate the output voltage. The switching moment of thyristor TS 154 is determined by a voltage at the gate of the thyristor which is the sum of a DC regulation voltage from terminal 10 of IC 150 and a sawtooth voltage caused by the emitter current of TS 153 through resistor R 1114//R 1115.

The voltage regulator IC 150 is fed at terminal 12 with the supply voltage and at terminal 7 with a negative voltage, via GR 161, from winding 3—8 of transformer T 102.

IC 150 contains a differential amplifier with inputs at terminals 4 and 5.

The input at terminal 5 is grounded via R 1104 and the

input at terminal 4 is connected to a voltage divider that consists of the reference output at terminal 6 and the negative voltage from winding 3—8 of transformer T 102 at terminal 7.

The differential amplifier is in balance when the voltage at terminal 7 is -5 V. When the supply voltage across windings 4—9 of transformer T 102 increases, the voltage at the differential amplifier at terminal 7 of IC 150 will go more negative, the DC regulation voltage at terminal 10 of IC 150 will go positive and turn on thyristor TS 154. This will connect the base of driver transistor to the ground and cause switch transistor TS 153 to switch off. The stored magnetic flux will then discharge in the secondary windings of T 102 and diodes GR 155—GR 159.

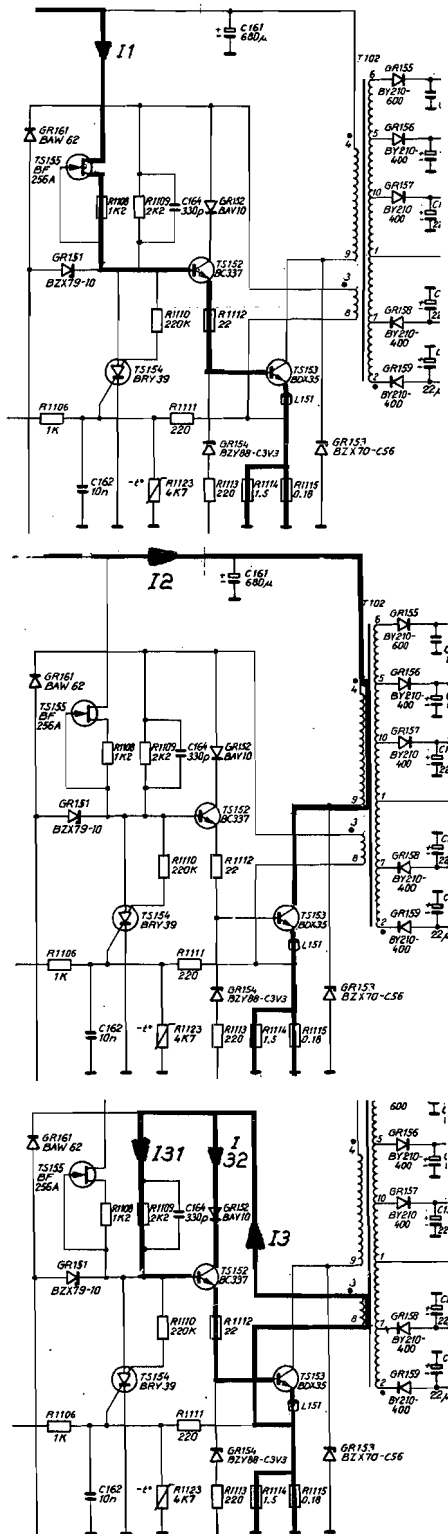

Fig. X 1. Current paths in DC to DC converter

## 6. Test conditons

### 6.1. DC voltages.

The d.c. voltages in the circuit diagrams are typical and may vary slightly between instruments.

Unless otherwise stated the voltages are positive related to earth and measured without input signal. The test instrument can be analogue or digital with an input impedance of at least 40 k $\Omega$ /V.

**NOTE.** When measuring d.c. voltages in the input amplifier of the prescaler use sampling oscilloscope PM 3400 and FET probe PM 9353.

### 6.2. Troubleshooting the power supply section

A fault in the power supply can be isolated easier if the counter circuits are disconnected by removing

10-pins connector BU 107. However, to simulate the load, a dummy load has to be fitted as shown in the figure. The dummy load can be assembled of the following components:

1 female connector 10 pins	5322 267 54102
1 carbon resistor 22 $\Omega$ , 1 W	4822 110 23143
1 carbon resistor 220 $\Omega$ , 1 W	4822 110 23089
1 carbon resistor, 18 $\Omega$ , 2 W	4822 110 10061
1 carbon resistor, 56 $\Omega$ , 0.5 W	4822 110 53074
1 carbon resistor, 5.6 k $\Omega$ , 0.5 W	4822 110 53127

**CAUTION:** + 120 V at pin 10 of the connector!

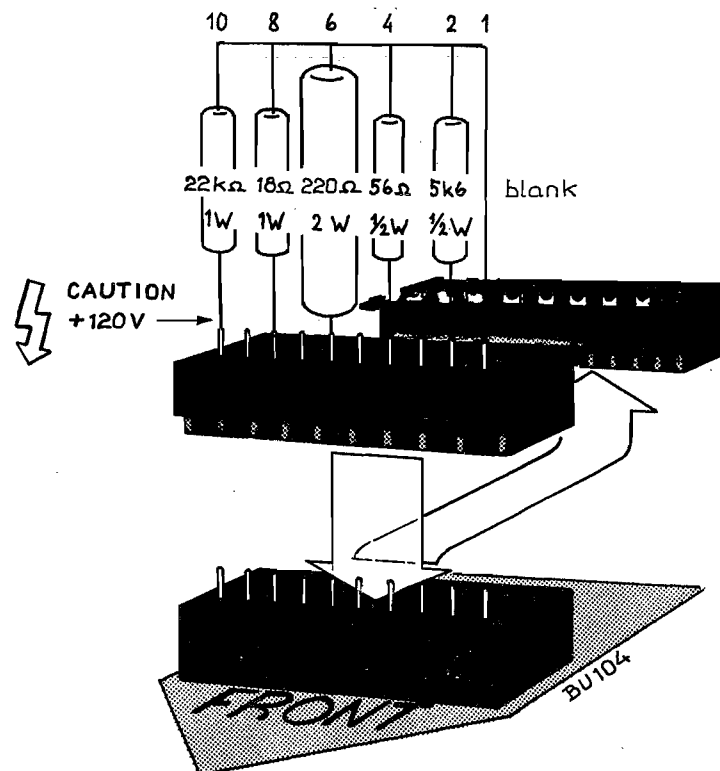



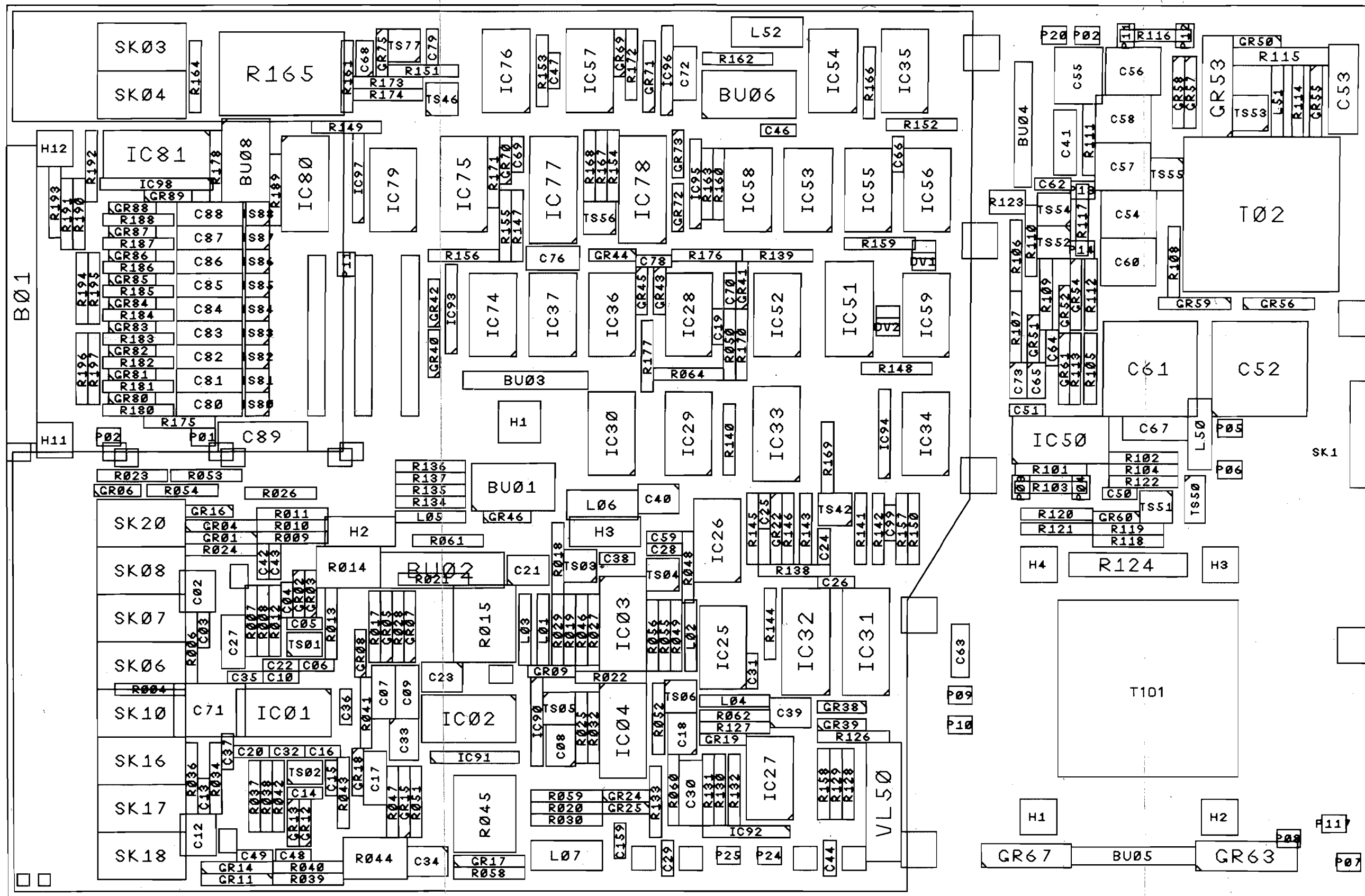
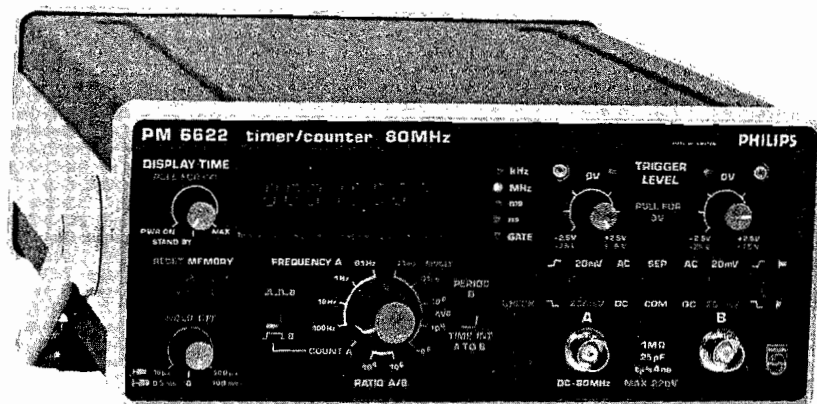

Figure X-2. Component layout U1

# PHILIPS



**PM 6622**  
9446 066 220.1

Instruction manual

Anleitung

Notice d'emploi et d'entretien

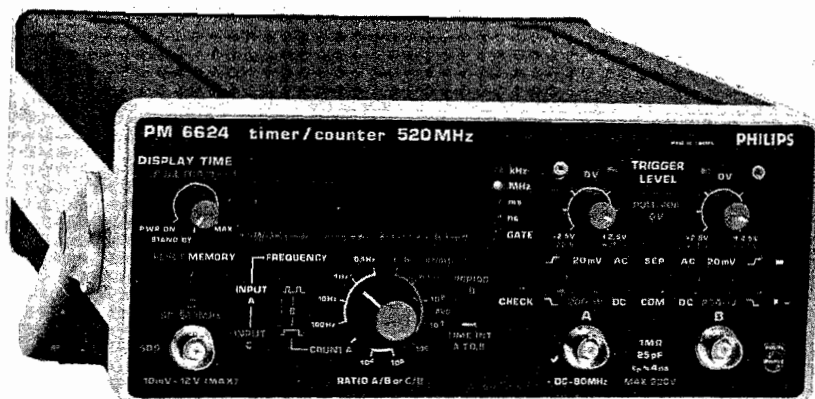

**PM 6624**  
9446 066 240.1

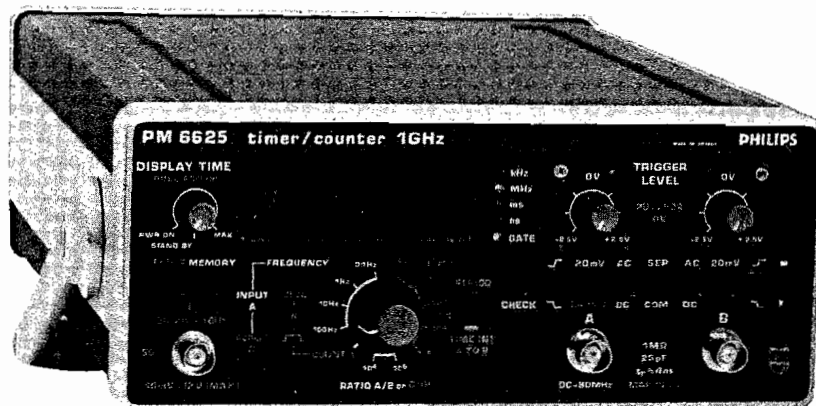

**PM 6625**  
9446 066 250.1

## IMPORTANT

In correspondence concerning this instrument, please quote the type number and the serial number as given on the type plate on the rear of the instrument.

## WICHTIG

Bei Schriftwechsel dieses Gerät betreffend, bitte die auf dem Typenschild an der Geräterückseite angegebene Typ- und Seriennummer zu vermelden.

## IMPORTANT

Dans votre correspondance et dans vos réclamations se rapportant à cet appareil, veuillez toujours indiquer le numéro de type et le numéro de série qui sont marqués sur la plaquette signalétique.

## CONTENTS

Introduction	3
Technical data	3
Options	7
Installation	10
Controls	12
Operation	19
Measurement	22

## INHALT

Einleitung	3
Technische Daten	3
Zubehör	8
Installation	10
Bedinungsorgane	12
Betrieb	19
Messungen	22

## TABLE DES MATIÈRES

Introduction	3
Caractéristiques Techniques	3
Options	8
Installation	11
Organes de commande	12
Mise en service	19
Mesures	22

## Safety regulations

Upon delivery, the instrument complies with the required safety regulations. To maintain this condition and to ensure safe operation, it is recommended to follow the instructions below.

### 1. Before switching on

**Protection** The instrument is protected according to class 1 (protective earth) of the IEC 348 or VDE 0411. The mains cable provides earth connection. Outside specially protected rooms, the mains plug must be connected only to sockets with earthed contact. It is not allowed to interrupt the earth connection inside or outside the instrument.

**Mounting** The instrument may be used in any desired position. Do not place the instrument on any surface which produces or radiates heat, or in direct sunlight.

**Earthing** The instrument must be earthed in conformity with the local safety regulations. The mains cable delivered with the instrument includes a protective conductor, which is connected to the earth contacts of the plug. Thus, when connected to an earthed mains socket, the cabinet of the instrument is consequently connected to the protective earth. The circuit earth is connected internally to the external BNC socket and the cabinet. The BNC socket must not be used to connect a protective conductor. **Warning** Connect the mains cable plug only to a socket with protective earth contacts. This protection must not be ineffective e.g. by using an extension cable without earth protection.

**Mains connection** The instrument must be connected only to an AC supply. On delivery the instrument is set to 230 V or 115 V indicated on the plate at the rear of the instrument. Ensure that the instrument is set to the local mains voltage before switching on.

Mains connection must be made in accordance with the local safety regulations. This implies that the instrument is connected to the mains socket with a protective earth contact as described in section Earthing.

**Mains Adjustment and Fuses** The instrument can be set to 115 V or 230 V. In both cases the fuse should be 1.6 A fast action, in addition to this the primary side of the mains transformer is protected by a replaceable thermal fuse. To convert the instrument proceed as follows:

- Unplug the mains cable
- Dismantle the instrument as described in section dismantling
- Resolder the wires of the mains transformer as shown on page 10.

### 2. Maintenance and Repair

**Failure and Extensive Stress** If the instrument is suspected of being unsafe take it out of operation. This is the case when the instrument shows physical damage or does not function anymore or is stressed beyond the tolerable limits e.g. during storage or transportation.

**Dismantling the instrument** When removing covers or other parts by means of tools, live parts or terminals could be exposed. Before opening the instrument, disconnect it from all power sources. If the open live instrument needs calibration, maintenance or a repair, it must be performed only by trained personnel being aware of the risks. After disconnection from all power sources, the capacitors in the instrument may remain charged for some seconds, observe the circuit diagrams. To dismantle the instrument proceed as follows:

- Unplug the mains cable
- Loosen the four rear screws
- Remove top and bottom covers

**Repair and replacing parts** Repairs must be made by trained personnel. Ensure that the construction of the instrument is not altered to the detriment of safety. Above all, leakage paths, air gaps and insulation layers must not be reduced. When replacing, use only original parts. Other spare parts are only acceptable when the safety precautions for the instrument are not impaired.

## Schutzmassnahmen

Dieses Gerät entspricht bei der Werksauslieferung den geltenden Schutzvorschriften. Zur Erhaltung dieses Zustands und zur Gewährleistung der Betriebssicherheit wird die genaue Einhaltung nachstehender Hinweise empfohlen.

### 1. Vor der Inbetriebnahme

**Schutzart** Das Gerät entspricht der Schutzklasse I (Schutzleiteranschluss) gemäss IEC 348 bzw. VDE 0411. Die Geräteanschlussleitung enthält einen Schutzleiter. Ausser in Räumen mit besonderen Schutzmassnahmen darf das Gerät nur an Steckdosen mit Schutzkontakten (Schuko-Steckdosen) angeschlossen werden. Jede Unterbrechung des Schutzleiters innerhalb oder ausserhalb des Geräts ist unzulässig.

**Aufstellung** Das Gerät ist für jede Betriebslage vorgesehen. Wärmeinwirkung und direkte Sonneneinstrahlung sind zu vermeiden.

**Erdung** Das Gerät ist nach Massgabe der örtlichen Vorschriften zu erden. Der Schutzleiter der Geräteanschlussleitung ist an die Schutzkontakte des Steckers angeschlossen. Auf diese Weise ist das Gehäuse des Geräts zwangsläufig mit Erde verbunden. Das Masse-Potential steht mit der äusseren BNC-Buchse und dem Gehäuse in Verbindung. Der Anschluss des Schutzleiters an die BNC-Buchse ist nicht zulässig. **Zu beachten!** Netzstecker nur an Schuko-Steckdosen anschliessen. Diese Schutzmassnahme darf nicht unwirksam gemacht werden (z.B. durch Verwendung einer Verlängerungsschnur ohne Schutzleiter).

**Netzanschluss** Das Gerät ist nur für Betrieb an Wechselspannung vorgesehen. Werksmässig ist es auf die Spannung 230 V oder 115 V eingestellt (Typenschild auf der Geräterückwand beachten!). Bei Bedarf also erst auf die örtliche Netzspannung umschalten. Der Netzanschluss muss den örtlichen Schutzvorschriften entsprechen. In jedem Fall ist aber Anschluss über eine Steckvorrichtung mit Schutzkontakten erforderlich; siehe oben unter »Erdung«.

**Spannungswahl und Sicherungen** Das Gerät ist auf 115 V oder 230 V einstellbar. In beiden Fällen sind feilnke Sicherungen 1,6 A zu verwenden. Die Primärseite des Netztransformators ist zusätzlich durch eine auswechselbare Thermosicherung geschützt. Die Umschaltung wird wie folgt vorgenommen:

- Netzstecker ziehen
- Gehäuse abnehmen (siehe unten)
- Die Drähte am Netztransformator entsprechend der Skizze auf Seite 10 umlöten

### 2. Wartung und Reparatur

**Fehler und Überbeanspruchung** Bei Verdacht der Betriebsunsicherheit Gerät aus dem Betrieb nehmen. Dies kann der Fall sein bei sichtbaren Beschädigungen, Funktionsausfall oder übermässigen Beanspruchungen (Transport, Lagerung und dgl.).

**Abnehmen des Gehäuses** Beim Entfernen von Abdeckungen und Bauteilen können unter Spannung stehende Teile freigelegt werden. Vor dem Öffnen ist das Gerät daher von allen Spannungsquellen zu trennen. Abstimmung, Wartung oder Reparaturen unter Spannung dürfen nur von geschulten Fachkräften, die mit den Gefahren vertraut sind, vorgenommen werden. **Zu beachten!** Auch nach Spannungsunterbrechung sind geladene Kondensatoren noch für einige Zeit spannungsführend (Schaltplan beachten!). Gehäuse wie folgt abnehmen:

- Netzstecker ziehen
- Die vier hinteren Schrauben lösen
- Gehäuseteile oben und unten abnehmen

**Reparaturen und Auswechslung von Teilen** Reparaturen sind nur von Fachkräften auszuführen. Die Bauweise des Geräts darf unter keinen Umständen für den Geräteschutz nachteilig geändert werden. Insbesondere dürfen die Kriechstrecken, Sicherheitsabstände und Isolierschichten keinesfalls beeinträchtigt werden. Nur Originalersatzteile verwenden! Andere Ersatzteile sind nur zulässig, sofern sich daraus keine Nachteile für den Geräteschutz ergeben.

## Prescriptions de sécurité

A la livraison, cet appareil satisfait aux normes de sécurité en vigueur. Afin de le maintenir conforme à ces normes et d'assurer son fonctionnement dans de bonnes conditions de sécurité, il est recommandé de se conformer aux instructions ci-dessous.

### 1. Avant la mise en marche

**Protection** L'appareil est protégé conformément à la classe 1 (ligne de terre protectrice) des normes IEC 348 ou VDE 0411. Son câble secteur comporte une connexion de terre. A l'extérieur des locaux spécialement protégés, ne connecter la fiche secteur qu'à des prises dotées d'un contact de terre. Toute interruption de la connexion de terre à l'intérieur ou à l'extérieur de l'appareil est proscrite.

**Installation** L'appareil peut être utilisé dans n'importe quelle position en fonction des besoins de l'utilisateur. Ne pas le placer sur une surface produisant ou rayonnant de la chaleur, ni à la lumière solaire directe.

**Mise à la terre** Mettre l'appareil à la terre conformément aux normes de sécurité locales en vigueur. Le câble secteur livré avec l'appareil comprend un conducteur protecteur relié aux contacts de terre de la fiche. Lorsqu'il est branché à une prise secteur avec terre, l'appareil a ainsi son coffret relié à la ligne de terre protectrice, laquelle est connectée intérieurement à la prise BNC externe du coffret. Ne pas utiliser cette dernière pour connecter un conducteur de protection.

**Attention** Ne brancher la fiche du câble secteur qu'à des prises dotées de contacts de terre. Ne pas neutraliser cette protection en utilisant par exemple un prolongateur sans conducteur de terre.

**Branchement au secteur** N'alimenter l'appareil qu'en courant alternatif. A sa livraison, il est couplé pour 230 V ou 115 V suivant l'indication de la plaquette placée à sa partie arrière. Bien s'assurer qu'il est couplé sur la tension secteur locale avant de le mettre en marche. La connexion de l'appareil au secteur devant être effectuée conformément aux normes locales de sécurité, elle doit comporter une ligne de terre protectrice comme décrit au chapitre Mise à la terre.

**Sélection du secteur et fusibles** L'appareil peut être couplé pour 115 V ou 230 V. Dans les deux cas le fusible doit être 1.6 à action rapide, en sus de ce le côté principal du transformateur secteur est protégé par un fusible thermique démontable. Pour modifier le couplage de l'appareil, procéder de la manière suivante:

- Débrancher le câble Secteur
- Ouvrir l'appareil comme décrit au chapitre Ouverture
- Ressouder les fils du transformateur Secteur Conformément aux figures à la page 10

### 2. Maintenance et réparation

**Défauts et contraintes sévères** Si la sécurité de fonctionnement de l'appareil est jugée incertaine, le retirer du service. C'est notamment le cas lorsqu'il présente des dommages matériels ou ne fonctionne plus ou encore a été soumis à des contraintes hors tolérances, par exemple lors de l'entreposage ou du transport.

**Ouverture de l'appareil** Lors de l'enlèvement des capots ou autres parties au moyen d'outils, des organes ou des bornes sous tension peuvent se trouver exposés. Avant d'ouvrir l'appareil, le déconnecter par conséquent de toute source d'alimentation. Si l'appareil ouvert et sous tension nécessite un calibrage, une opération de maintenance ou une réparation, ne confier le travail qu'à du personnel qualifié et conscient des risques encourus. Après déconnexion des sources d'alimentation, les condensateurs de l'appareil peuvent rester chargés pendant quelques secondes, voir les schémas de connexions. Pour ouvrir l'appareil, procéder de la manière suivante:

- Débrancher le câble Secteur
- Enlever les quatre vis du fond
- Tirer les coffrets du haut et du bas

**Réparation et remplacement de pièces** Les réparations doivent être effectuées par du personnel qualifié. S'assurer que la constitution de l'appareil n'est pas modifiée au détriment de la sécurité. Avant tout, les lignes de fuite, les entrefers et les revêtements isolants ne doivent pas être réduits. Pour tout échange, n'utiliser que des pièces détachées d'origine. Les autres pièces de rechange ne sont acceptables que si le niveau de sécurité de l'appareil reste inchangé.

# Sales and service all over the world

**Alger:** Sadetel; 41 Rue des Frères Mouloud, Alger; tel. 656613-656607

**Argentina:** Philips Argentina S.A., Cassila Correo 3479, Buenos Aires; tel. 70.7741 al 7749

**Australia:** Philips Scientific & Industrial Equipment Division, Centre Court, 25 - 27 Paul Street, P.O. Box 119, North Ryde/NSW 2113; tel. 88 88222

**Bangla Desh:** Philips Bangla Desh Ltd. P.O. Box 62; Ramna, Dacca, tel. 28332

**België/Belgique:** S.A. M.B.L.E., Philips Scientific and Industrial Equipment Division; 80 Rue des Deux Gares, 1070 Bruxelles; tel. 2/513.76.00/523.00.00

**Bolivia:** Industrias Bolivianas Philips S.A. Cajón Postal 2964, La Paz; tel.: 50029/55270/55604

**Brasil:** S.A. Philips Do Brasil; Avenida 9 de Julho 5229; Caixa Postal 8681; CEP 01407 - São Paulo (S.P.); tel. 282-5722/282-1611

**Burundi:** Philips S.A.R.L., Avenue de Grèce, B.P. 900, Bujumbura

**Canada:** Philips Test and Measuring Instruments Inc.; 6 Leswyn Road, Toronto (Ontario) M6A-1K2; tel. (416) 789-7188

**Chile:** Philips Chilena S.A., Casilla 2687, Santiago de Chile; tel. 394001/770038

**Colombia:** Industrias Philips de Columbia S.A., Calle 13 no. 51-03, Apartado Aereo 4282, Bogota; tel. 611877

**Costa Rica:** Philips de Costa Rica Ltd., Apartado Postal 4325, San José; tel. 210111

**Danmark:** Philips Elektronik Systemer A/S, Afd. for Industri og Forskning; Strandlodsvej 4, P.O. Box 1919, 2300 København S; tel. 01-57-2222; telex 27045

**Deutschland (Bundesrepublik):** Philips GmbH, Unternehmensbereich Elektronik für Wissenschaft und Industrie, Postfach 310 320; 35 Kassel-Bettenhausen, Miramstrasse 87; tel. 561-5011

**Ecuador:** Philips Ecuador S.A., Casilla 343, Quito; tel. 239080

**Egypt:** Ph. Scientific Bureau, 5 Sherif Str., Cairo - A.R. Egypt, P.O. Box 1687; tel. 78457-57739-914293

**Eire:** Philips Electrical (Ireland) Ltd., Newstead, Clonskeagh, Dublin 14; tel. 693355

**El Salvador:** Philips de El Salvador S.A., Apartado Postal 865, San Salvador; tel. 21-7441

**España:** Philips Ibérica S.A.E., Dpto Aparatos de Medida, Martínez Villergas 2, Apartado 2065, Madrid 27; tel. 404-2200/3200/4200

**Ethiopia:** Philips Ethiopia (Priv. Ltd. Co.), P.O.B. 2565; Ras Abebe Areguay Avenue, Addis Ababa; tel. 13440

**Finland:** See Suomi

**France:** S.A. Philips Division S&I, Division de la S.A. Philips Industrielle et Commerciale, 105 Rue de Paris, 93 002 Bobigny; tel. 830-11-11

**Ghana:** Philips (Ghana) Ltd., P.O.B. M 14, Accra; tel. 66019

**Great Britain:** Pye Unicam Ltd, York Street, Cambridge CB1-2PX; tel. (0223) 58866  
**Service Centre:**  
Pye Unicam Ltd., Beddington Lane, Croydon, Surrey CR9-4EN; tel. 01-684-3670

**Greece:** See Hellas

**Guatemala:** Philips de Guatemala S.A., Apartado Postal 238, Ciudad de Guatemala, Zona 9; tel. 64857

**Hellas:** Philips S.A. Hellénique, 54 Avenue Syngrou, Athens 403; P.O. Box 153, tel. 9215311

**Hong Kong:** Philips Hong Kong Ltd., P.O.B. 2108, St. George's Building, 21st floor, Hong Kong city; tel. 5-249246

**India:** Philips India Ltd., Shivsagar Estate, Block "A", Dr. Annie Besant Road, P.O.B. 6598, Worli, Bombay 18; tel. 370071/391431

**Indonesia:** P.T. Philips Development Corporation Jalan Proklamasi 33, P.O.B. 2287, Jakarta; tel. 51985/51986/81876

**Iran:** Philips Iran Ltd., P.O.B. 1297, Teheran; tel. 662281-5

**Iraq:** Philips Iraq W.L.L., Munir Abbas Building, 4th floor; South Gate, P.O. box 5749, Baghdad; tel. 80409/98844

**Island:** Heimilisteaki SF, Saetún 8, Reykjavik; tel. 24000

**Islas Canarias:** Philips Ibérica S.A.E., Triana 132, Las Palmas; Casilla 39-41, Santa Cruz de Tenerife

**Italia:** Philips S.p.A., Sezione S&I; Viale Elvezia 2, 20052 Monza; tel. 36351, telex Mi 35290

**Japan:** See Nippon

**Kenya:** Philips (Kenya) Ltd., P.O.B. 30554, Nairobi; tel. 29981

**Kuwait:** Delegate Office of Philips Industries, P.O.Box 3801; Kuwait, tel. 33814

**Malaysia:** Philips Malaya Sdn Bhd., P.O. Box 2163, Petaling Jaya, Kuala Lumpur; Selangor, W. Malaya; tel. 774411

**México:** Philips Mexicana S.A. de C.V., Calle Durango 167, Div. Científico Industrial, Apartado Postal 24-328 Mexico 7 (D.F.); tel. 525 15 40

**Morocco:** Samtel, 2 Rue de Bapaume, Casablanca; tel. 243050-243052

**Nederland:** Philips Nederland B.V., Hoofdgroep PPS, Boschdijk 525, Gebouw VB, Eindhoven; tel. 793333

**Ned. Antillen:** Philips Antillana N.V., Postbus 523, Willemstad; Curaçao; tel. 37575-35464

**New Zealand:** Philips Electrical Industries of N.Z. Ltd., Scientific and Industrial Equipment Division Wakefield Street 181-195, P.O.B. 2097, Wellington; tel. 859-859

**Nigeria:** Philips (Nigeria) Ltd., 6 Ijora Causeway, P.O.B. 1921, Lagos; tel. 45414/7

**Nippon:** Nihon Philips Corporation, Shuwa Shinagawa Building, 26-33 Takanawa 3 - Chome, Minato-Ku, Tokyo 108; P.O. Box 13; tel. (03) 448-5574

**Norge:** Norsk A.S. Philips, Industri og Forsking, Essendrops gate 5, Postboks 5040, Oslo 3; tel. 463890

**Österreich:** Oesterreichische Philips Industrie GmbH, Abteilung Industrie Elektronik, Breitenfurterstrasse 219, A-1230 Wien; tel. (222)-831501/05

**Pakistan:** Philips Electrical Co. of Pakistan Ltd., El-Markaz, M.A. Jinnah Road, P.O.B. 7101, Karachi 3; tel. 70071

**Paraguay:** Philips del Paraguay S.A., Casilla de Correo 605, Asunción; tel. 48045-46919

**Perù:** Philips Peruana S.A., Apartado Aereo 1841, Lima 5; tel. 326070

**Philippines:** Philips Industrial Development Inc., 2246 Pasong Tamo, P.O.B. 911, Makati Rizal D-708; tel. 889453 to 889456; 868951

**Portugal:** Philips Portuguesa S.A.R.L., Av. Eng.º Duarte Pacheco 6, Apartado 1331, Lisboa 1; tel. 683121/9

**Rwanda:** Philips Rwanda S.A.R.L. B.P. 449, Kigali.

**Saudi Arabia:** A. Rajab and A. Siislah, P.O. Box 203, Jeddah - Saudi Arabia; tel. 27392/5

**Schweiz-Suisse-Svizzera:** Philips A.G., Binzstrasse 15, Postfach 307, Ch 8027 Zürich; tel. 442211

**Singapore:** Philips Singapore Private Ltd., P.O. Box 340, Toa Payoh Central Post Office; Singapore 12; tel. 538811

**South Afrika:** South African Philips (Pty) Ltd., P.O.B. 7703, 2 Herb Street, New Doornfontein, Johannesburg 2000; tel. 240531

**South-Korea:** Philips Electronics (Korea) Ltd., P.O. Box 3680, Seoul; tel. 737222

**Suomi:** Oy Philips Ab., Kaivokatu 8, P.O. Box 10255, 00101 Helsinki 10; tel. 17271

**Sverige:** Svenska A.B. Philips, Philips Industrietelektronik, Lidingövägen 50, Fack, S10250 Stockholm; tel. 635000

**Syria:** Philips Moyen-Orient S.A., Rue Fardoss 79, Immeuble Kassas and Sadate, B.P. 2442, Damas; tel. 18605-21650

**Taiwan:** Philips Taiwan Ltd., San Min Building, P.O. Box 22978, Taipei

**Tanzania:** Philips (Tanzania) Ltd., Box 20104, Dar es Salaam; tel. 29571

**Thailand:** Philips Electrical Co. of Thailand Ltd., 283 Silom Road, P.O. Box 961, Bangkok; tel. 233-6330

**Tunisia:** S.T.I.E.T., 32815, Rue Ben Ghedhahem, Tunis; tel. 244268

**Türkiye:** Türk Philips Ticaret A.S., Posta Kutusa 504, Beyoglu, Gümüssüyü Caddesi 78/80, Istanbul 1; tel. 435910

**Uganda:** Philips Uganda Ltd., P.O. Box 5300, Kampala; tel. 59039

**Uruguay:** Industrias Philips del Uruguay S.A., Avda Uruguay 1287, Casilla de Correo 294, Montevideo; tel. 915641/44

**U.S.A.:** Philips Test and Measuring Instruments Inc., 85, Mc Kee Drive, Mahwah, New Jersey 07430, tel. (201) 529-3800

**Venezuela:** Industrias Venezolanas Philips S.A., Apartado Aereo 1167, Caracas 107; tel. 360511/363011/362255

**Zaire:** Philips S.Z.R.L., B.P. 1798, Kinshasa; tel. 31887-31888-31693-31208

**Zambia:** Philips Electrical Ltd., Professional Equipment Division, P.O.B. 553; Kitwe; tel. 2526/7/8

T&M/780501

**For information on change of address:**  
N.V. Philips' Gloeilampenfabrieken  
Test and Measuring Instruments Dept.  
Eindhoven - The Netherlands

**For countries not listed:**  
N.V. Philips S&I Export Dept.  
Test and Measuring Instruments Dept.  
Eindhoven - The Netherlands

## 1. Introduction

The counters in the PM 6620-series have frequency ranges from dc up to 80 MHz, 520 MHz and 1 GHz respectively for the PM 6622, PM 6624 and PM 6625. All models can measure frequency, ratio, period, time interval and have a totalizing mode. Optional accessories such as five different oscillators, a battery unit, a BCD output unit, a D/A converter and a BUS interface system extend the range of application.

## 2. Technical data

Properties expressed in numerical values with statement of tolerances are guaranteed. Numerical values without tolerances are intended for information purposes only and indicate the properties of an average instrument. The numerical values hold good for the nominal mains voltage.

## Measurements

### Frequency A

Range: dc to 80 MHz

Gate times: 10 ms, 100 ms, 1 s and 10 s

Resolution: 100 Hz, 10 Hz, 1 Hz and 0.1 Hz

Accuracy:  $\pm 1$  count  $\pm$  time base error

### Frequency C

Range PM 6624: 50 MHz to 520 MHz

Range PM 6625: 50 MHz to 1000 MHz

Gate times PM 6624: 10 ms, 100 ms, 1 s and 10 s automatically multiplied with prescaling factor 8

Gate times PM 6625: 10 ms, 100 ms, 1 s and 10 s automatically multiplied with prescaling factor 16

Resolution: 100 Hz, 10 Hz, 1 Hz and 0.1 Hz

Accuracy:  $\pm 1$  count  $\pm$  time base error

### Single Period B

Range: 100 ns to  $10^5$  s (dc to 10 MHz)

Resolution: 100 ns and 100  $\mu$ s

Accuracy:  $\pm 1$  count  $\pm$  time base error  $\pm$  trigger error\*

Frequency counted: 10 MHz and 10 kHz

### Period Average B

Range: 1 Hz to 10 MHz

Periods averaged (N):  $10^2$ ,  $10^4$  and  $10^6$

Resolution:  $\frac{100 \text{ ns}}{N}$

Accuracy:  $\pm 1$  count  $\pm$  time base error  $\pm$  trigger error\*/N.

Frequency counted: 10 MHz

## 1. Einleitung

Die Universalzähler der PM 6620-Serie eignen sich für Messungen in den Frequenzbereichen von Gleichspannung bis 80 MHz (PM 6622) bzw. 520 MHz (PM 6624) und 1 GHz (PM 6625). Mit allen Modellen ist die Messung von Frequenz, Frequenzverhältnis, Periodendauer, Zeitintervall sowie Ereigniszählung möglich. Der Anwendungsbereich kann durch Zusatzeinheiten wie fünf verschiedene Oszillatoren, eine Batterie-Einheit, einen BCD-Ausgang, einen D/A-Wandler und ein BUS-Interfacesystem noch wesentlich erweitert werden.

## 2. Technische Daten

In Zahlen mit Toleranzangabe ausgedrückte Eigenschaften sind Garantiewerte. Zahlen ohne Toleranzangabe dienen nur zur Information des Anwenders und stellen die Eigenschaften eines typischen Gerätes dar. Die Zahlenwerte gelten für Nenn-Netzspannung.

## Messarten

### Frequenz A

Bereich: 0 ... 80 MHz

Meßzeiten: 10 ms, 100 ms, 1 s und 10 s

Auflösung: 100 Hz, 10 Hz, 1 Hz und 0,1 Hz

Genauigkeit:  $\pm 1$  digit  $\pm$  Zeitbasisfehler

### Frequenz C

Bereich PM 6624: 50 MHz ... 520 MHz

Bereich PM 6625: 50 MHz ... 1000 MHz

Meßzeiten PM 6624: 10 ms, 100 ms, 1 s und 10 s, automatisch multipliziert mit dem Verteilerfaktor 8

Meßzeiten PM 6625: 10 ms, 100 ms, 1 s und 10 s, automatisch multipliziert mit dem Verteilerfaktor 16.

Auflösung: 100 Hz, 10 Hz, 1 Hz und 0,1 Hz

Genauigkeit:  $\pm 1$  digit  $\pm$  Zeitbasisfehler

### Einzelperiode B

Bereich: 100 ns ...  $10^5$  s (0 ... 10 MHz)

Auflösung: 100 ns und 100  $\mu$ s

Genauigkeit:  $\pm 1$  digit  $\pm$  Zeitbasisfehler  $\pm$  Triggerfehler\*

Zählfrequenz: 10 MHz und 10 kHz

### Periodendauer-Mittelwert B

Bereich: 1 Hz ... 10 MHz

Mittelwertbildung über N Perioden:  $10^2$ ,  $10^4$  und  $10^6$

Auflösung:  $\frac{100 \text{ ns}}{N}$

## 1. Introduction

Les compteurs PM 6622, PM 6624, PM 6625 de la série PM 6620, offrent respectivement, des gammes de fréquence du continu à 80 MHz, 520 MHz, et 1 GHz.

Ils permettent tous trois de mesurer la fréquence, le rapport, la période l'intervalle de temps, et sont équipés d'un mode de totalisation. Les accessoires en option, tels que : cinq oscillateurs différents, une unité de batterie, une unité de sortie BCD, un convertisseur D/A et un interface BUS, permettent d'étendre la gamme d'applications.

## 2. Caractéristiques Techniques

Les caractéristiques exprimées en valeurs numériques avec mention de tolérances sont garanties. Les valeurs numériques sans mention de tolérance sont données à titre indicatif seulement, et ce, pour la moyenne des appareils. Les valeurs numériques sont valables pour une tension secteur nominale.

## Mesures

### Fréquence A

Gamme : continu à 80 MHz

Temps de porte : 10 ms, 100 ms, 1 s et 10 s

Résolution : 100 Hz, 10 Hz, 1 Hz et 0.1 Hz

Précision :  $\pm 1$  impulsion  $\pm$  erreur de base de temps

### Fréquence C

Gamme PM 6624 : 50 MHz à 520 MHz

Gamme PM 6625 : 50 MHz à 1000 MHz

Temps de porte PM 6624 : 10 ms, 100 ms, 1 s, et 10 s multipliés — automatiquement avec facteur de pré-éta-lonnage 8

Temps de porte PM 6625 : 10 ms, 100 ms, 1 s et 10 s multipliés — automatiquement avec facteur de pré-éta-lonnage 16

Résolution: 100 Hz, 10 Hz, 1 Hz, et 0.1 Hz

Précision :  $\pm 1$  impulsion  $\pm$  erreur de basé de temps

### Période simple B

Gamme : 100 ns à  $10^5$  s (continu à 10 MHz)

Résolution : 100 ns et 100  $\mu$ s

Précision :  $\pm 1$  impulsion  $\pm$  erreur de base de temps  $\pm$  erreur de déclenchement\*

Fréquence comptée : 10 MHz et 10 KHz

**Single Time Interval A to B**Range: 100 ns to 10<sup>5</sup> s

Resolution: 100 ns and 100 μs

Time interval repetition rate: maximum 5 MHz

Accuracy: ± 1 count ± time base error ± trigger error\*\*

Frequency counted: 10 MHz and 10 kHz

**Time Interval Average A to B**

Range: 1 ns to 1 s

Frequency counted: 10 MHz

Periods averaged (N): 10<sup>2</sup>, 10<sup>4</sup> and 10<sup>6</sup>

Statistical resolution: 100 ns/√N

Minimum time from stop to start: 250 ns

Accuracy: ± 4 ns ± time base error ± 100 ns trigger error\*\*

$$\frac{100 \text{ ns}}{\sqrt{N}}$$

Time Interval repetition rate: maximum 4 MHz

**Count A (totalizing)**Range: 1 to 10<sup>9</sup>

Mode: accumulates pulses between a start and stop pulse or during a gate signal applied to input B

Pulse pair resolution: 12 ns

**Multiple Ratio**Ratio fA/fB:  $\frac{\text{dc to } 80 \text{ MHz}}{\text{dc to } 10 \text{ MHz}}$ Ratio fC/fB PM 6624:  $\frac{50 \text{ to } 520 \text{ MHz}}{\text{dc to } 10 \text{ MHz}}$ Ratio fC/fB PM 6625:  $\frac{50 \text{ to } 1000 \text{ MHz}}{\text{dc to } 10 \text{ MHz}}$ 

Accuracy: ± 1 count ± trigger error\* of B/N

Multiplier (N): 10<sup>4</sup> and 10<sup>6</sup> with correct decimal pointRatio measurements with a multiplier factor: N = 10<sup>5</sup> to 10<sup>8</sup> are obtained in Frequency measurements. In Single Period and Period Average measurements multiplier factors of 1, 10<sup>2</sup>, 10<sup>4</sup> and 10<sup>6</sup> can be obtained by using the external reference input.

This arrangement will not give correct decimal points.

**Trigger Hold Off only PM 6622**

Measuring modes: the trigger hold off (or trigger delay) works in Single Period and Single Time Interval modes.

Range: from less than 10 μs to 100 ms in two ranges.

Monitor output: the hold off time is

Genauigkeit: ± 1 digit ± Zeitbasisfehler ± Triggerfehler\*/N  
Zählfrequenz: 10 MHz**Einzelzeitintervall A—B**Bereich: 100 ns ... 10<sup>5</sup> s

Auflösung: 100 ns und 100 μs

Zeitintervall-Wiederholfrequenz: max. 5 MHz

Genauigkeit: ± 1 digit ± Zeitbasisfehler ± Triggerfehler\*

Zählfrequenz: 10 MHz und 10 kHz

**Zeitintervall-Mittelwert A—B**

Bereich: 1 ns ... 1 s

Zählfrequenz: 10 MHz

Mittelwertbildung über N Perioden: 10<sup>2</sup>, 10<sup>4</sup> und 10<sup>6</sup>Statistische Auflösung:  $\frac{100 \text{ ns}}{\sqrt{N}}$ 

Mindestzeit zwischen Start und Stopp: 250 ns

Genauigkeit: ± 4 ns ± Zeitbasisfehler ± 100 ns ± Triggerfehler\*\*  
 $\pm \frac{100 \text{ ns}}{\sqrt{N}}$ 

Zeitintervall-Wiederholfrequenz: max. 4 MHz

**Zählung A (Summenbildung)**Bereich: 1 ... 10<sup>9</sup>

Betrieb: Summiert Impulse zwischen einem Start- und einem Stoppsignal oder während eines Torsignals an Eingang B

Impulspaar-Auflösung: 12 ns

**Frequenzverhältnis**

Verhältnis fA/fB:

DC ... 80 MHz/DC ... 10 MHz

Verhältnis fC/fB (PM 6624):

50 ... 520 MHz/DC ... 10 MHz

Verhältnis fC/fB (PM 6625):

50 ... 1000 MHz/DC ... 10 MHz

Genauigkeit: ± 1 digit ± Triggerfehler\* von B/N

Multiplikator (N): 10<sup>4</sup> und 10<sup>6</sup> mit korrektem DezimalpunktVerhältnismessung mit einem Multiplikator: N = 10<sup>5</sup> bis 10<sup>8</sup> sind im Frequenz-Betrieb zu erhalten, während bei Messung von Periodendauer und Periodendauer-Mittelwert die Multiplikatoren 1, 10<sup>2</sup>, 10<sup>4</sup> und 10<sup>6</sup> durch Verwendung des externen Referenzeingangs erhältlich sind.

Dieses Verfahren liefert jedoch keinen korrekten Dezimalpunkt.

\* Der Triggerfehler beträgt höchstens ± 3 × 10<sup>-3</sup> für Sinus bei einem Signal-Rauschverhältnis von min. 40 dB.

\*\* Der Triggerfehler für beliebige Signalformen beträgt höchstens

$$\pm \frac{2,5 \times 10^{-3}}{\text{Signalflanke (V/ns)}} \text{ ns}$$

**Période moyenne B**

Gamme: 1 Hz à 10 MHz

Périodes mises en moyenne (N): 10<sup>2</sup>, 10<sup>4</sup> et 10<sup>6</sup>Résolution:  $\frac{100 \text{ ns}}{N}$ 

Précision: ± 1 impulsion ± erreur de base de temps ± erreur de déclenchement\*/N

Fréquence comptée: 10 MHz

**Intervalle de temps simple A — B**Gamme: 100 ns à 10<sup>5</sup> s

Résolution: 100 ns et 100 μs

Taux de répétition d'intervalle de temps: Maximal de 5 MHz

Précision: ± 1 impulsion ± erreur de base de temps ± erreur de déclenchement\*\*

Fréquence comptée: 10 MHz et 10 KHz

**Moyenne d'intervalle de temps A — B**

Gamme: 1 ns à 1 s

Fréquence comptée: 10 MHz

Périodes mises en moyenne (N): 10<sup>2</sup>, 10<sup>4</sup> et 10<sup>6</sup>

Résolution statistique: 100 ns/√N

Temps minimal arrêt/démarrage:

250 ns

Précision: ± 4 ns ± erreur de base de temps ± 100 ns erreur de déclenchement\*\*/√N

Taux de répétition d'intervalle de temps: Maximal de 4 MHz

**Comptage A (totalisation)**Gamme: 1 à 10<sup>9</sup>

Mode: accumule les impulsions pendant l'intervalle de temps entre le signal d'arrêt ou le signal de porte appliqué à l'entrée B

Résolution de paire d'impulsions: 12 ns

**Rapport multiple**

Rapport fA/fB:

continu à 80 MHz, continu à 10 MHz

Rapport fC/fB PM 6624:

50 à 520 MHz, continu à 10 MHz

Rapport fC/fB PM 6625:

50 à 1000 MHz, continu à 10 MHz

Multiplicateur (N): 10<sup>4</sup> et 10<sup>6</sup> avec le point décimal correcte

Précision: ± 1 impulsion ± erreur\* de déclenchement de B/N.

\* Trigger error is ≤ ± 3 × 10<sup>-3</sup> for sine wave signals with signal to noise ratio of ≥ 40 dB.\*\* Trigger error for any wave shape is  
 $\leq \pm \frac{2,5 \times 10^{-3}}{\text{Signal slope (V/ns)}} \text{ ns}$ \* L'erreur de déclenchement est ≤ ± 3 × 10<sup>-3</sup> pour signaux sinusoïdaux avec rapport signal/bruit ≥ 40 dB.\*\* L'erreur de déclenchement pour chaque sinusoïde est ≤ ±  $\frac{2,5 \times 10^{-3}}{\text{pente du signal (V/ns)}} \text{ ns}$



monitored on the Gate Open output and can be digitally measured by the instrument itself.

### Check

**Hold off not activated:** 10 MHz is internally applied to channels A and B and a functional self test of any measuring mode can be made.

**Hold off activated:** the set Hold Off duration will be displayed if Single Period or Time Interval mode is selected.

## Input characteristics

### Inputs A and B

**General:** inputs A and B are identical but input B is functionally limited to 10 MHz

**Frequency range:** dc to 80 MHz at dc coupling and 100 Hz to 80 MHz at ac coupling

**Rise time:** approximately 4 ns

**Pulse resolution:** 6 ns minimum pulse duration

**Sensitivity:** 20 mV<sub>rms</sub> and 200 mV<sub>rms</sub> for sine wave signals, 60 mV<sub>p-p</sub> and 600 mV<sub>p-p</sub> for pulses

**Impedance:** 1 M $\Omega$ //25 pF

**Trigger level:** preset to 0 V or variable between  $\pm 2.5$  V and  $\pm 25$  V in two ranges with higher resolution around 0 V

**Trigger level monitor:** set trigger voltages from  $-2.5$  V to  $+2.5$  V are available on 1 mm jacks at the front

**Trigger slope:** positive and negative

**Coupling:** dc and ac

**Safe overload at 20 mV sensitivity setting:** 250 V dc or 230 V<sub>rms</sub> for frequencies up to 440 Hz falling to 12 V<sub>rms</sub> for frequencies of 1 MHz and higher

**Safe overload at 200 mV sensitivity setting:** 250 V dc or 230 V<sub>rms</sub>

**Switching mode:** separate or common

### Input C

**Range:** 50 MHz to 520 MHz for PM 6624 and 50 MHz to 1000 MHz for PM 6625

**Prescaling factor:** 8 for PM 6624 and 16 for PM 6625

**Dynamic input voltage range:** 10 mV<sub>rms</sub> to 12 V<sub>rms</sub> ( $-27$  dBm to  $+35$  dBm). Above 960 MHz the sensitivity of PM 6625 might drop to  $-24$  dBm (14 mV<sub>rms</sub>)

**Impedance:** 50 $\Omega$

**Attenuation:** continuous by automatic PIN diode attenuation, maximum 62 dB

**Coupling:** ac

**VSWR:** less than 2

**AM tolerance:** 98 % at modulation frequencies up to 5 kHz. 30 % at modulation frequencies of 1 MHz and higher.

**Safe overload:** 12 V<sub>rms</sub>

### Triggersperre (nur PM 6622)

**Betrieb:** Die Triggersperre (Triggervverzögerung) HOLD OFF arbeitet bei Messungen von Einzelperioden und Einzelzeitintervall.

**Bereich:** Von unter 10  $\mu$ s bis 100 ms in zwei Bereichen.

**Anzeige:** Die Sperre wird am Ausgang GATE OPEN angezeigt und kann vom Instrument selbst digital gemessen werden.

### Check

**Triggersperre nicht betätigt:** Ein 10-MHz-Signal wird intern an die Kanäle A und B angelegt. Dadurch ist eine funktionelle Eigenkontrolle jeder Meßfunktion möglich.

**Triggersperre betätigt:** Bei Messung von Periodendauer oder Zeitintervall wird die eingestellte Dauer der Triggersperre HOLD OFF angezeigt.

## Eingangscharakteristika

### Eingänge A und B

**Allgemeines:** Die Eingänge A und B sind identisch, nur ist die Funktion von Eingang B auf 10 MHz begrenzt.

**Frequenzbereich:** DC bis 80 MHz bei DC-Kopplung und 100 Hz bis 80 MHz bei AC-Kopplung

**Anstiegszeit:** ca. 4 ns

**Impulsaufösung:** min. Impulsdauer 6 ns

**Empfindlichkeit:** 20 mV<sub>eff</sub> und 200 mV<sub>eff</sub> für Sinussignale, 60 mV<sub>SS</sub> und 600 mV<sub>SS</sub> für Impulse

**Impedanz:** 1 M $\Omega$ //25 pF

**Triggerpegel:** Voreingestellt auf 0 V oder variabel zwischen  $\pm 2,5$  V und  $\pm 25$  V mit höherer Auflösung um 0 V

**Triggerpegelanzeige:** Eingestellte Triggerspannungen von  $-2,5$  V bis  $+2,5$  V können an Miniaturbuchsen auf der Frontseite abgenommen werden

**Triggerflanke:** Positiv und negativ

**Kopplung:** DC und AC

**Überlastungsschutz bei 20 mV:** 250 V DC oder 230 V<sub>eff</sub> bei Frequenzen von bis zu 440 Hz, abfallend auf 12 V<sub>eff</sub> bei 1 MHz oder mehr

**Überlastungsschutz bei 200 mV:** 250 V DC oder 230 V<sub>eff</sub>

**Schaltart:** Gemeinsam oder getrennt

### Eingang C

**Bereich:** 50 MHz bis 520 MHz (PM 6624) bzw. 50 MHz bis 1000 MHz (PM 6625)

**Vorteilerfaktor:** 8 für PM 6624 und 16 für PM 6625

**Dynamischer Eingangsspannungsbereich:** 10 mV<sub>eff</sub> bis 12 mV<sub>eff</sub> ( $-27$  dBm bis  $+35$  dBm). Über 960 MHz

**Mesures de rapport avec un facteur multiplicateur:**  $N = 10^5$  à  $10^8$  sont obtenus en mesures de fréquence. Pour les mesures en Période Simple et Période moyenne les facteurs multiplicateurs de 1,  $10^2$ ,  $10^4$  et  $10^6$  peuvent être obtenus en utilisant une entrée de référence externe.

Toutefois, cet arrangement ne fournira pas de points décimaux correctes.

### Déclenchement HOLD OFF seulement PM 6622

**Modes de mesures:** le déclencheur Hold Off fonctionne en mode de — Période Simple et en mode d'intervalle de temps simple.

**Sortie contrôle:** le temps de retard est commandé sur la sortie de porte ouverte et peut être mesuré digitalement par l'instrument lui-même.

**Gamme:** moins que 10  $\mu$ s 0 100 ms en deux gammes

### Vérification

**Hold Off non-déclenché:** 10 MHz est appliqué intérieurement aux voies A et B et un auto-contrôle fonctionnel peut être effectué selon n'importe quel mode de mesure

**Hold Off Déclenché:** la durée réglée de Hold Off sera affichée après la sélection de soit le mode de Période Simple, ou le mode d'intervalle de temps.

## Caractéristiques d'Entrée

### Entrées A et B

**Généralités:** les entrées A et B sont identiques mais, l'entrée B est limitée à une fonction de 10 MHz

**Gamme de fréquence:** continu à 80 MHz avec couplage en continu, et  $-100$  Hz à 80 MHz avec couplage capacitif

**Temps de montée:** approximativement 4 ns

**Résolution des impulsions:** durée minimum de 6 ns par impulsion

**Sensibilité:** 20 mV<sub>eff</sub> et 200 mV<sub>eff</sub> pour les signaux d'ondes sinusoïdales 60 mV<sub>c-c</sub> et 600 mV<sub>c-c</sub> pour les impulsions

**Impédance:** 1 M-ohm//25 pF

**Niveau de déclenchement:** pré-réglé sur 0 V ou variable entre  $\pm 2.5$  V et  $\pm 25$  V en deux gammes avec une résolution supérieure près de 0 V

**Commande du niveau de déclenchement:** des tensions de déclenchement réglées de  $-2.5$  V à  $+2.5$  V sont obtenues sur les bornes avant

**Pente de déclenchement:** positive et négative

**Couplage:** continu ou capacitif



### External reference input D

**General:** channel D is switchable between external reference frequency input and internal reference oscillator output

**Frequency range:** 1 kHz to 10 MHz with correct decimal point at 10 MHz

**Sensitivity:** 500 mV<sub>rms</sub>

**Impedance:** approximately 10 k $\Omega$

**Coupling:** ac

**Safe overload:** 50 V<sub>rms</sub>

### External reset and start

**Reset:** via a 0 V  $\pm$  0,4 V signal applied to the input socket

**Minimum time between trailing edge and start of new measurement:** 200 ns

**Minimum reset pulse duration:** 100 ns

**Input current:** at 0,4 V maximum 0,4 mA

**Start of new measurement:** when the input is returned to a voltage of more than +2,5 V (max. 5,5 V) or left open

the counter is released to carry out a new measurement. If the Display Time Control is set to infinite position only one new measurement is made and stored and the counter can not start a new measurement until a new reset pulse has been applied.

### Output characteristics

#### Time base oscillator output D

**General:** channel D is switchable between external reference frequency input and time base oscillator output

**X-tal frequency:** 10 MHz

**Amplitude:** approximately 1 V<sub>rms</sub>, open circuit

**Impedance:** approximately 200  $\Omega$

**Coupling:** dc

**Safe overload:** short circuit proof

#### Gate monitor output

**General:** the gate monitor output enables observation on an oscilloscope of the measured interval (and the hold off time on the PM 6622)

**Output level during open main gate:** less than 0,4 V

**Output level during closed main gate:** more than 2,5 V

**Output level during hold off time:** approximately 1,5 V

**Output impedance:** approximately 400  $\Omega$

**Delay:** internal delay between the signal inputs and the trigger monitor output is approximately 65 ns

**Overload protection:** short circuit proof

### General characteristics

#### Display

**Read out:** planar 9 digits 7 segments gas discharge display with automatic decimal point

kann die Empfindlichkeit des PM 6625 auf  $-24$  dBm (14 mV<sub>eff</sub>) abfallen

**Impedanz:** 50  $\Omega$

**Dämpfung:** Kontinuierlich durch automatischen PIN-Dioden-Abschwächer, max. 62 dB

**Kopplung:** AC

**VSWR:** Unter 2

**AM-Toleranz:** 98% bei Modulationsfrequenzen bis zu 5 kHz. 30% bei Modulationsfrequenzen von 1 MHz und mehr

**Überlastungsschutz:** 12 V<sub>eff</sub>

### Externer Referenzeingang D

**Allgemeines:** Der Kanal D ist umschaltbar zwischen externem Referenzfrequenz-Eingang und internem Referenz-Oszillator-Ausgang

**Bereich:** 1 kHz bis 10 MHz mit korrektem Dezimalpunkt bei 10 MHz

**Empfindlichkeit:** 500 mV<sub>eff</sub>

**Impedanz:** ca. 10 k $\Omega$

**Kopplung:** AC

**Überlastschutz:** 50 V<sub>eff</sub>

### Externes Rückstell-/Startsignal

**Rückstellung:** über ein 0  $\pm$  0,4 V-Signal am Eingang

**Mindestzeit zwischen Rückflanke und Beginn der neuen Messung:** 200 ns

**Min. Rückstellimpulsdauer:** 100 ns

**Eingangsstrom:** max. 0,4 mA bei 0,4 V

**Start einer neuen Messung:** Wird der Eingang auf über + 2,5 V (max. 5,5 V) rückgestellt oder offen gelassen, so wird der Zähler für eine neue Messung freigegeben. Steht die Anzeigezeit auf unendlich, wird nur eine Messung durchgeführt und gespeichert. Der Zähler ist dann bis zum Anlegen eines neuen Rückstellsignals gesperrt.

### Ausgangscharakteristika

#### Zeitbasis-Oszillator, Ausgang D

**Allgemeines:** Der Kanal D ist umschaltbar zwischen externem Referenzfrequenz-Eingang und internem Zeitbasis-Oszillator-Ausgang

**Ausgangsfrequenz:** 10 MHz

**Amplitude:** ca. 1 V<sub>eff</sub> bei Leerlauf

**Impedanz:** 200  $\Omega$

**Kopplung:** DC

**Überlastschutz:** kurzschlussfest

#### Gate-Monitor-Ausgang

**Allgemeines:** Der Gate-Monitor-Ausgang ermöglicht es, das gemessene Zeitintervall (und die Triggervverzögerung beim PM 6622) auf einem Oszilloskop zu überwachen.

**Ausgangsspegel bei offenem Haupttor:** unter 0,4 V

**Ausgangsspegel bei geschlossenem Haupttor:** über 2,5 V

**Ausgangsspegel während Triggervverzögerung:** ca. 1,5 V

**Protection de surcharge ; pour réglage de sensibilité à 20 mV :** 250 V continu ou 230 V<sub>eff</sub> pour les fréquences montant jusqu'à 440 Hz, tombant ensuite à 12 V<sub>eff</sub> pour les fréquences de 1 MHz à monter

**Protection de surcharge pour réglage de sensibilité à 200 mV :** 250 V continu ou 230 V<sub>eff</sub>

**Modes d'entrée :** séparée ou commune

### Entrée C

**Gamme :** 50 MHz à 520 MHz pour PM 6624 et 50 MHz à 1000 MHz pour PM 6625

**Facteur de pré-étalonnage :** 8 pour PM 6624, et 16 pour PM 6625

**Gamme de tension dynamique d'entrée:** 10 mV<sub>eff</sub> à 12 mV<sub>eff</sub> ( $-27$  dBm à  $+35$  dBm). Audessus de 960 MHz la sensibilité pourrait baisser jusqu'à  $-24$  dBm, 14 mV<sub>eff</sub>

**Impédance :** 50 ohm

**Atténuation :** par atténuateur à diodes PIN automatique, 62 dB maximum

**Couplage :** capacitif

**Taux d'ondes stationnaires (VSWR) :**  $< 2$

**Tolérance AM :** 98 % en modulation de fréquence allant jusqu'à 5 kHz, 30 % en modulation de fréquence de 1 MHz à monter

**Protection de surcharge :** 12 V<sub>eff</sub>

### Entrée de référence externe D

**Généralité :** la voie D est commutable entre l'entrée externe à fréquence de référence, et la sortie de l'oscillateur à référence interne

**Gamme de fréquence :** 1 kHz à 10 MHz avec point décimale correcte à 10 MHz

**Sensibilité :** 500 mV<sub>eff</sub>

**Impédance :** approximativement 10 k-ohm

**Couplage :** capacitif

**Protection de surcharge :** 50 V<sub>eff</sub>

### Remise à zéro/Démarrage externe

**Remise à zéro :** via un signal de 0 V  $\pm$  0,4 V appliqué à l'entrée EXT. RESET

**Temps minimum entre la suite d'un affichage et le démarrage d'une nouvelle mesure :** 200 ns

**Durée minimum de l'impulsion de remise :** 100 ns

**Courant d'entrée :** 0,4 mA max. à 0,4 V

**Démarrage d'une nouvelle mesure :** quand l'entrée est remise à une tension supérieure à + 2,5 V (5,5 V Max.) ou que l'entrée est maintenue ouverte, une nouvelle mesure est alors démarrée.

Si la commande DISPLAY TIME est réglée pour un temps d'affichage infini, alors une seule nouvelle mesure est démarrée et stockée. Le compteur ne peut pas alors faire démarrer une nou-

**Unit annunciators:** kHz, MHz, ms and ns

**Display time:** 50 ms to 4 s and infinite  
**Reset:** pushing "Reset" resets the counter, releasing it starts new measurement

**Gate lamp:** indicates that main gate is open and counting takes place. In the Stand By position the gate lamp indicates that the line voltage or battery is connected for X-tal oscillator stabilization.

**Memory:** display storage holds reading between samples and can be switched off by front panel "Memory" push-button

**Trigger indicator:** tri state LED with stretched operation (channels A and B). Light on indicates too high trigger level, light off too low trigger level and blinking indicates that triggering occurs.

#### Power requirements

**Line voltage:** 115/230 V  $\pm 15\%$

**Line frequency:** 45 to 440 Hz

**Consumption:** depending on type no, crystal oscillator and options. Approximately 15 VA.

**Mains interference:** below Class II CENELEC/CISPR

**Internal battery:** PM 9673, power consumption approximately 8 W

**External battery:** 11.8 to 28 V, power consumption approximately 8 W. 4 mm banana connectors.

**Oven oscillator:** power consumption 100 mA in Stand By position

#### Environmental conditions

**Storage temperature:**  $-40^{\circ}\text{C}$  to  $+70^{\circ}\text{C}$

**Operating temperature:**  $0^{\circ}\text{C}$  to  $+50^{\circ}\text{C}$

**Storage altitude:** 15000 m (15.2 kN/m<sup>2</sup>)

**Operating altitude:** 5000 m (53.3 kN/m<sup>2</sup>)

**Humidity:** 10 to 90 % RH (26°C dew point)

**Vibration test:** IEC 68 Fc

**Bump test:** IEC 68 Eb

**Handling test:** IEC 68 Ec

**Transport test:** NLN-L88

#### Dimensions and Weight

**Width:** 210 mm (8.25")

**Height:** 89 mm (3.5")

**Depth:** 325 mm (12.8")

**Weight:** 2.8 kg (6.2 lb)

### 3. Options

#### Standard oscillator PM 9677

**Frequency:** 10 MHz

**Trimming range:** more than  $\pm 200$  Hz

**Output voltage into 1 k $\Omega$ :** more than 300 mV

**Supply voltage:** 12 V

**Consumption:** less than 100 mW at 25°C

**Ausgangsimpedanz:** ca. 400  $\Omega$

**Verzögerung:** Die interne Verzögerung zwischen den Signaleingängen und dem Triggermonitor-Ausgang beträgt ca. 65 ns.

**Überlastungsschutz:** kurzschlußfest.

### Allgemeine Daten

#### Anzeige

**Ablesung:** Planar, 9 Stellen; 7-Segment-Gasentladungsröhren mit automatischem Dezimalpunkt

**Einheitenangabe:** kHz, MHz, ms und ns

**Anzeigedauer:** 50 ms bis 4 s und unbegrenzt

**Rückstellung:** Drücken des Knopfes RESET stellt den Zähler auf Null zurück. Durch Loslassen wird eine neue Zählung gestartet.

**GATE Lampe:** Zeigt an, daß das Haupttor offen ist und eine Zählung stattfindet. In der Stellung STAND BY zeigt die Lampe GATE an, daß Netz oder Batterie anliegen, um den Quarz-Oszillator zu stabilisieren.

**Speicher:** Die Anzeigespeicherung hält die Anzeige zwischen Meßvorgängen. Sie läßt sich durch die frontseitige Drucktaste MEMORY abschalten.

**Triggeranzeige:** Tristabile LED-Kontrollampen (Kanal A und B). Lampe EIN zeigt zu hohen und Lampe AUS zu niedrigen Triggerpegel an. Bei Triggerung Blinklicht.

#### Speisung

**Netzspannung:** 115/230 V  $\pm 15\%$

**Netzfrequenz:** 45 bis 440 Hz

**Leistungsaufnahme:** Abhängig von Typennr., Quarzoszillator und Zubehör; ca. 15 VA

**Netzstörungen:** unter Class II CENELEC/CISPR

**Interne Batterie:** PM 9673, Leistungsverbrauch ca. 8 W

**Externe Batterie:** 11,8 bis 28 V, Leistungsverbrauch ca. 8 W; 4-mm-Banana-stecker

**Geheizter Oszillator:** Verbrauch 100 mA in Bereitschaftsbetrieb (Stand by)

#### Umgebungsbedingungen

**Lagertemperatur:**  $-40^{\circ}\text{C}$  bis  $+70^{\circ}\text{C}$

**Betriebstemperatur:**  $0^{\circ}\text{C}$  bis  $+50^{\circ}\text{C}$

**Lagerhöhe:** 15000 m (15,2 kN/m<sup>2</sup>)

**Betriebshöhe:** 5000 m (53,3 kN/m<sup>2</sup>)

**Feuchtigkeit:** 10 bis 90 % rel. Luftfeuchtigkeit (Taupunkt 26°C)

**Vibrationsfestigkeit:** nach IEC 68 Fc

**Stoßfestigkeit:** nach IEC 68 Eb

**Bedienungstest:** nach IEC 68 Ec

**Transporttest:** nach NLN-88

velle mesure jusqu'à ce qu'une nouvelle impulsion de remise soit appliquée

### Caractéristiques de sortie

#### Sortie oscillateur base de temps D

**Généralités:** la voie D est commutable entre l'entrée externe de la fréquence de référence et la sortie de l'oscillateur base de temps

**Fréquence cristal:** 10 MHz

**Amplitude:** approx. 1 V<sub>eff</sub> à circuit ouvert

**Impédance:** approx. 200 ohm

**Couplage:** alternatif

**Protection de surcharge:** contre les court-circuits

#### Sortie témoin de porte

**Généralités:** la sortie témoin de porte permet l'observation sur un oscilloscope d'un intervalle mesuré, (ainsi que le temps de retard sur le PM 6622)

**Niveau de sortie en porte principale ouverte:**  $< 0.4$  V

**Niveau de sortie en porte principale fermée:**  $> 2.5$  V

**Niveau de sortie en temps de retard:** approx. 1.5 V

**Sortie impédance:** approx. 400 ohm

**Retard:** le retard interne entre les signaux d'entrée et la sortie témoin du déclenchement est approx. de 65 ns

**Protection de surcharge:** contre les court-circuits

### Caractéristiques Générales

#### Affichage

**Sortie lecture:** 9 chiffres, affichage à 7 segments, (gaz), et avec point décimal automatique

**Indicateurs d'unités:** kHz, MHz, ms et ns

**Temps d'affichage:** 50 ms à 4 s et infini

**Remise à zéro:** la commande "RESET" enfoncée, remet le compteur à zéro, et en position relâchée une nouvelle mesure démarre

**Lampe de porte:** Indique que la porte principale est ouverte et que le comptage a lieu; en position d'attente, la lampe de porte indique que la tension secteur ou la batterie est appliquée en vue de la stabilisation de l'oscillateur cristal

**Mémoire:** l'affichage retient la lecture entre les informations et peut être grâce au bouton-poussoir "Memory" sur le panneau avant

**Indicateur de déclenchement:** LED tri-à opération prolongée (voies A et B). Lorsque la lampe est allumée en permanence, le niveau de déclenchement est trop élevé, lorsque la lampe est éteinte en permanence, le niveau de

**Ageing:** less than  $5 \times 10^{-7}$  per month  
**Temperature deviation 0°C to 50°C:** less than  $1 \times 10^{-5}$  with reference to +25°C

**Change in measuring and supply mode:** less than  $3 \times 10^{-7}$

**Line voltage  $\pm 10\%$  deviation:** less than  $1 \times 10^{-8}$

**Environmental data:** same as the counter

**Dimension:** 93×50×20 mm

**Weight:** 50 g

### TCXO PM 9678

**Frequency:** 10 MHz

**Trimming range:** more than  $\pm 20$  Hz will cover at least 10 years of operation

**Output voltage into 1 k $\Omega$ :** more than 100 mV

**Supply voltage:** 12 V

**Consumption:** less than 200 mW at 25°C

**Ageing:** less than  $1 \times 10^{-7}$ /month, the ageing will decrease substantially after the first 6 months

**Temperature deviation 0°C to 50°C:** less than  $1 \times 10^{-6}$  with reference to +25°C

**Change in measuring and supply mode:** less than  $5 \times 10^{-8}$

**Line voltage  $\pm 10\%$  deviation:** less than  $1 \times 10^{-9}$

**Environmental data:** same as the counter

**Dimensions:** 93×50×15 mm

**Weight:** 25 g

### Oven oscillator PM 9679B

**Frequency:** 10 MHz

**Trimming range:** + 20 Hz and — 30 Hz fine trimming range. A coarse trimmer is available to adjust for an ageing of more than 10 years

**Output voltage into 1 k $\Omega$ :** more than 150 mV

**Supply voltage:** + 11.5 to 28 V from unregulated power supply

**Consumption at continuous operation and stand by:** less than 125 mA

**Warm up consumption:** less than 400 mA

**Ageing:** less than  $1 \times 10^{-7}$ /month after 72 hours of continuous operation

**Temperature deviation (0°C to 50°C):** less than  $1 \times 10^{-7}$  with reference to 25°C

**Line voltage ( $\pm 10\%$  deviation):** less than  $1 \times 10^{-9}$

**Change in measuring and supply mode:** less than  $1 \times 10^{-8}$

**Warm up time:** less than 15 minutes to reach  $1 \times 10^{-7}$

**Environmental data:** same as the counter

**Dimension:** 100 × 52 × 35 mm

**Weight:** 100 g

### Abmessungen und Gewicht

**Breite:** 210 mm

**Höhe:** 89 mm

**Tiefe:** 325 mm

**Gewicht:** 2,8 kg

### 3. Zubehör

#### Standard Oszillator PM 9677

**Frequenz:** 10 MHz

**Abstimmbereich:** mehr als  $\pm 200$  Hz

**Ausgangsspannung an 1 k $\Omega$ :** mehr als 300 mV

**Speisespannung:** 12 V

**Verbrauch:** unter 100 mW bei 25°C

**Alterung:** unter  $5 \times 10^{-7}$  pro Monat

**Temperaturabweichung 0°C bis 50°C:** unter  $1 \times 10^{-5}$  bezogen auf +25°C

**Wechsel von Betriebsart und Speisung (Netz/Batterie):** unter  $3 \times 10^{-7}$

**Netzspannung  $\pm 10\%$ :** unter  $1 \times 10^{-8}$

**Umgebungsbedingungen:** wie der Zähler

**Abmessungen:** 93×50×20 mm

**Gewicht:** 50 g

#### TCXO PM 9678

**Frequenz:** 10 MHz

**Abstimmbereich:** über  $\pm 20$  Hz; ausreichend für min. 10 Betriebsjahre

**Ausgangsspannung an 1 k $\Omega$ :** über 100 mV

**Speisespannung:** 12 V

**Verbrauch:** unter 200 mW bei 25°C

**Alterung:** unter  $1 \times 10^{-7}$  pro Monat; nach den ersten sechs Monaten nimmt die Alterung bedeutend ab.

**Temperaturabweichung 0°C bis 50°C:** unter  $1 \times 10^{-6}$  bezogen auf +25°C

**Wechsel von Betriebsart und Speisung (Netz/Batterie):** unter  $1 \times 10^{-8}$

**Netzspannung  $\pm 10\%$ :** unter  $1 \times 10^{-9}$

**Umgebungsbedingungen:** wie der Zähler

**Abmessungen:** 93×50×15 mm

**Gewicht:** 25 g

#### Geheizter Oszillator PM 9679B

**Frequenz:** 10 MHz

**Abstimmbereich:** + 20 Hz und — 30 Hz zur Feinabstimmung. Zum Abgleich einer Alterung von mehr als 10 Jahren ist ein Grobtrimmer vorgesehen

**Ausgangsspannung an 1 k $\Omega$ :** über 150 mV

**Speisespannung:** + 11,5 bis 28 V aus nichtstabilisierter Speisung

**Verbrauch bei Dauerbetrieb und Stand by:** unter 125 mA

**Verbrauch bei Anheizung:** unter 400 mA

**Alterung:** unter  $1 \times 10^{-7}$  pro 24 h nach 72 Stunden Dauerbetrieb

**Temperaturabweichung 0°C bis 50°C:** unter  $1 \times 10^{-7}$  bezogen auf +25°C

**Netzspannung  $\pm 10\%$ :** unter  $1 \times 10^{-9}$

**Wechsel von Betriebsart und Speisung (Netz/Batterie):** unter  $1 \times 10^{-8}$

déclenchement est trop bas, et quand la lampe clignote, le déclenchement est effectué

### Consommation

**Tension secteur:** 115/230 V  $\pm 15\%$

**Fréquence secteur:** 45 à 440 Hz

**Consommation:** selon le numéro du modèle, l'oscillateur cristal et les options (approx. 15 VA)

**Interférence secteur:** Audessous de class II SENELEC CISPR

**Batterie interne:** PM 9673, Consommation approx. 8 W

**Batterie externe:** 11.8 à 28 V avec une consommation d'environ 8 W, Connecteurs de 4 mm, type banane

**Oscillateur à enceinte thermostatée:** consommation de 100 mA en position d'attente

### Caractéristiques d'environnement

**Température de stockage:** — 40° C à + 70° C

**Température de fonctionnement:** 0° C à + 50° C

**Altitude de stockage:** 15000 m

(15.2 kN/m<sup>2</sup>)

**Altitude de fonctionnement:** 5000 m

(53.3 kN/m<sup>2</sup>)

**Humidité:** 10 à 90 % RH (26° C point requis)

**Epreuve à la vibration:** conforme à la norme IEC 68 Fc

**Epreuve au choc:** conforme à la norme IEC 68 Eb

**Epreuve manipulation:** conforme à la norme IEC 68 Ec

**Epreuve transportation:** conforme à la norme NLN-L88

### Dimensions et poids

**Largeur:** 210 mm (8.25")

**Hauter:** 89 mm (3.5")

**Profondeur:** 325 mm (12.8")

**Poids:** 2.8 Kg (6.2 lb)

### 3. Options

#### Oscillateur standard PM 9677

**Fréquence:** 10 MHz

**Gamme d'ajustement:** supérieure à  $\pm 200$  Hz

**Tension de sortie sous 1 k-ohm:** supérieure à 300 mV

**Tension d'alimentation:** 12 V

**Consommation:** inférieure à 100 mW pour 25 C

**Usure:** inférieure à  $5 \times 10^{-7}$  pour un mois

**Déviaton de température de 0° C à 50° C:** inférieure à  $1 \times 10^{-5}$  par rapport à + 25° C

**Variation de la mesure et du mode d'alimentation:** inférieure à  $3 \times 10^{-7}$

**Déviaton  $\pm 10\%$  de la tension secteur:** inférieure à  $1 \times 10^{-8}$

**Oven oscillator PM 9690****Frequency:** 10 MHz**Trimming range:** +3 Hz and —7 Hz fine trimming range. A coarse trimmer is available to adjust for an ageing of more than 10 years**Output voltage into 1k $\Omega$ :** more than 150 mV**Supply voltage:** +11.5 to 28 V from unregulated power supply**Consumption at continuous operation and stand by:** less than 125 mA**Warm up consumption:** less than 400 mA**Ageing:** less than  $1.5 \times 10^{-9}/24$  h after 72 hours of continuous operation**Temperature deviation 0°C to 50°C:** less than  $3 \times 10^{-8}$  with reference to + 25°C**Line voltage  $\pm 10\%$  deviation:** less than  $5 \times 10^{-10}$ **Change in measuring and supply mode:** less than  $3 \times 10^{-9}$ **Warm up time:** less than 15 minutes to reach  $1 \times 10^{-7}$ **Environmental data:** same as the counter**Dimensions:** 100 $\times$ 52 $\times$ 35 mm**Weight:** 100 g**Oven oscillator PM 9691****Frequency:** 10 MHz**Trimming range:** + 3 Hz and —7 Hz fine trimming range. A coarse trimmer is available to adjust for an ageing of more than 10 years**Output voltage into 1 k $\Omega$ :** more than 150 mV**Supply voltage:** + 11.5 to 28 V from unregulated power supply**Consumption at continuous operation and stand by:** less than 125 mA**Warm up consumption:** less than 400 mA**Ageing:** less than  $5 \times 10^{-10}/24$  h after 72 hours of continuous operation**Temperature deviation (0°C to 50°C):** less than  $5 \times 10^{-9}$  with reference to + 25°C**Line voltage ( $\pm 10\%$  deviation):** less than  $5 \times 10^{-10}$ **Change in measuring and supply mode:** less than  $3 \times 10^{-9}$ **Warm up time:** less than 15 minutes to reach  $1 \times 10^{-7}$ **Environmental data:** same as the counter**Dimension:** 100  $\times$  52  $\times$  35 mm**Weight:** 100 g**Rack mount adapter****PM 9669/01:** 19" rack for one counter**PM 9669/02:** 19" rack for two counters**Battery unit****PM 9673:** rechargeable battery for inside mounting**Anheizdauer:** unter 15 Minuten, um  $1 \times 10^{-7}$  zu erreichen**Umgebungsbedingungen:** wie der Zähler**Abmessungen:** 100  $\times$  52  $\times$  35 mm**Gewicht:** 100 g**Geheizter Oszillator PM 9690****Frequenz:** 10 MHz**Abstimmbereich:** +3 Hz und —7 Hz zur Feinabstimmung. Zum Abgleich einer Alterung von mehr als 10 Jahren ist ein Grobtrimmer vorgesehen**Ausgangsspannung an 1 k $\Omega$ :** über 150 mV**Speisespannung:** +11,5 bis 28 V aus nichtstabilisierter Speisung**Verbrauch bei Dauerbetrieb und Stand by:** unter 125 mA**Verbrauch bei Anheizung:** unter 400 mA**Alterung:** unter  $1,5 \times 10^{-9}$  pro 24 h nach 72 Stunden Dauerbetrieb**Temperaturabweichung 0°C bis 50°C:** unter  $3 \times 10^{-8}$  bezogen auf + 25°C**Netzspannung  $\pm 10\%$ :** unter  $5 \times 10^{-10}$ **Wechsel von Betriebsart und Speisung (Netz/Batterie):** unter  $3 \times 10^{-9}$ **Anheizdauer:** unter 15 Minuten, um  $1 \times 10^{-7}$  zu erreichen**Umgebungsbedingungen:** wie der Zähler**Abmessungen:** 100 $\times$ 52 $\times$ 35 mm**Gewicht:** 100 g**Geheizter Oszillator PM 9691****Frequenz:** 10 MHz**Abstimmbereich:** + 3 Hz und —7 Hz zur Feinabstimmung. Zum Abgleich einer Alterung von mehr als 10 Jahren ist ein Grobtrimmer vorgesehen**Ausgangsspannung an 1 k $\Omega$ :** über 150 mV**Speisespannung:** + 11,5 bis 28 V aus nichtstabilisierter Speisung**Verbrauch bei Dauerbetrieb und Stand by:** unter 125 mA**Verbrauch bei Anheizung:** unter 400 mA**Alterung:** unter  $1,5 \times 10^{-10}$  pro 24 h nach 72 Stunden Dauerbetrieb**Temperaturabweichung 0°C bis 50°C:** unter  $3 \times 10^{-9}$  bezogen auf + 25°C**Netzspannung  $\pm 10\%$ :** unter  $5 \times 10^{-10}$ **Wechsel von Betriebsart und Speisung (Netz/Batterie):** unter  $3 \times 10^{-9}$ **Anheizdauer:** unter 15 Minuten, um  $1 \times 10^{-7}$  zu erreichen**Umgebungsbedingungen:** wie der Zähler**Abmessungen:** 100  $\times$  52  $\times$  35 mm**Gewicht:** 100 g**Adapter für Einbaumontage****PM 9669/01:** 19"-Gehäuse für 1 Zähler**PM 9669/02:** 19"-Gehäuse für 2 Zähler**Batteriesatz****PM 9673:** Wiederaufladbare Batterie zur Montage im Zähler**Caractéristiques d'environnement :**

comme celles du compteur

**Dimension :** 93  $\times$  50  $\times$  20 mm**Poids :** 50 g**TCXO PM 9678****Fréquence :** 10 MHz**Gamme d'ajustement :** supérieure à  $\pm 20$  Hz, pouvant servir pendant au moins dix ans**Tension de sortie sous 1 k-ohm :** supérieure à 100 mV**Tension d'alimentation :** 12 V**Consommation :** inférieure à 200 mW à 25° C**Usure :** inférieure à  $1 \times 10^{-7}$  par mois, et diminuera substantiellement après les premiers six mois**Déviati on de température de 0° C à 50° C :** inférieure à  $1 \times 10^{-6}$  par rapport à + 25° C**Variation de la mesure et du mode d'alimentation :** inférieure à  $5 \times 10^{-8}$ **Déviati on  $\pm 10\%$  de la tension secteur :** inférieure à  $1 \times 10^{-9}$ **Caractéristiques d'environnement :**

Identiques à celles du compteur

**Dimension :** 93  $\times$  50  $\times$  15 mm**Poids :** 25 g**Oscillateur à enceinte thermostatée PM 9679B****Fréquence :** 10 MHz**Gamme d'ajustement :** + 20 Hz et — 30 Hz avec réglage fin. Un dispositif d'ajustement ordinaire est disponible pour suppléer à un usage de plus de dix ans**Tension de sortie sous 1 k-ohm :** supérieure à 150 mV**Tension d'alimentation :** + 11.5 à 28 V non-régulée**Consommation en opération continue et en position d'attente :** inférieure à 100 mA**Consommation au chauffage :** inférieure à 400 mA**Usure :** inférieure à  $1 \times 10^{-7}/24$  h après 72 heures d'opération continue**Déviati on de température de 0° C à 50° C :** inférieure à  $1 \times 10^{-7}$  par rapport à + 25° C**Déviati on  $\pm 10\%$  tension secteur :** inférieure à  $1 \times 10^{-9}$ **Variation de la mesure et du mode d'alimentation :** inférieure à  $1 \times 10^{-8}$ **Temps de chauffage :** inférieure à 15 minutes pour atteindre  $1 \times 10^{-7}$ **Caractéristiques d'environnement :**

Identiques à celles du compteur

**Dimensions :** 100  $\times$  52  $\times$  35 mm**Poids :** 100 g**Oscillateur à enceinte thermostatée PM 9690****Fréquence :** 10 MHz**Gamme d'ajustement :** + 3 Hz et —7 Hz avec réglage fin. Un dispositif d'ajuste-

**Carrying case**

**PM 9672:** carrying case for the counter and measuring leads during transportation

**Output interface units**

**PM 9674:** BCD output unit  
**PM 9675:** digital to analog converter  
**PM 9676:** bus interface unit

**Accessories included with the instrument**

Operation and service manual  
 Line cord  
 Front panel protective cover

**4. Installation**

**Mains voltage conversion:** the counter can be converted into two mains voltage ranges, 100 to 130 V and 200 to 260 V.

The frequency range is 45 to 440 Hz. At delivery the instrument is set to the 200 to 260 V range.

When changing to the 100 to 130 V range the connections of the mains transformer should be changed as shown in the figure below, and the "230 V" label covered with the "115 V" label supplied.

115 V

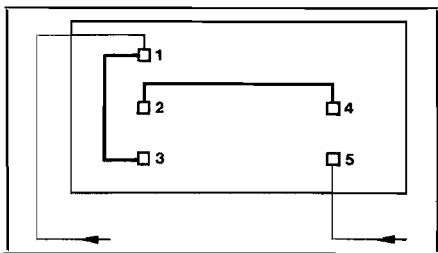

230 V

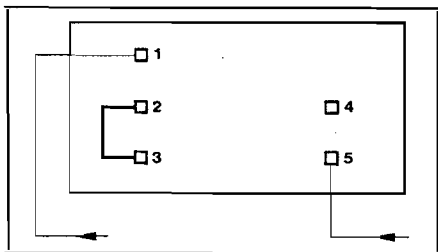

**Earthing:** the counter can be earthed via the protective earth terminal at the rear panel or via a three core mains cable plugged into an outlet with protective earth contact.

Use only one of these alternatives to avoid hum.

**Fuses:** a thermal fuse on the mains transformer and a 1.6 A fast action fuse are protecting the power supply.

**Options:** refer to installation instruction for each type number.

**Tragtasche**

**PM 9672:** Tragtasche für Gerät und Meßkabel

**Ausgangs-/Interface-Einheiten**

**PM 9674:** BCD-Ausgangseinheit  
**PM 9675:** Digital-/Analogwandler  
**PM 9676:** BUS-Interface

**Mitgeliefertes Zubehör**

Handbuch  
 Netzkabel  
 Frontplatten-Schutzdeckel

**4. Installation**

**Netzspannungsänderung:** Das Gerät läßt sich auf zwei Netzspannungsbereiche, 100—130 V und 200—260 V umschalten. Der Frequenzbereich ist 45 bis 440 Hz. Bei Lieferung ist der Zähler auf 200—260 V eingestellt.

Die Umschaltung auf 100—130 V geschieht durch Änderung der Anschlüsse des Netztransformators entspr. untenstehender Abbildung. Das Schild „230 V“ ist dann mit dem Schild „115 V“ zu überkleben.

115 V

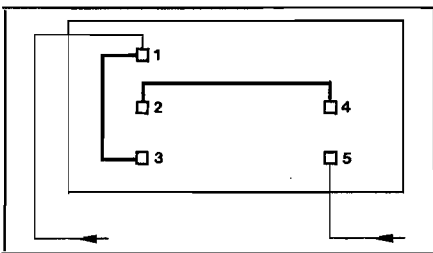

230 V

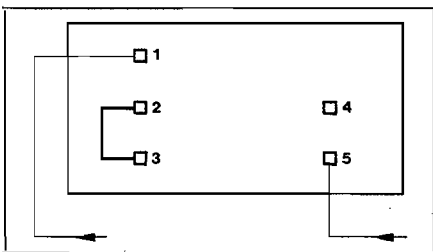

**Erdung:** Das Gerät ist entweder über die Schutzerdungsklemme auf der Rückseite oder über den Schutzleiter des Netzkabels (nur an Schutzkontakt-Steckdose anschließen!) zu erden.

Nur eine dieser Erdungsmöglichkeiten verwenden, um Brummen zu vermeiden.

**Sicherungen:** Der Netzteil ist durch eine thermische Sicherung am Netztrafo und eine flinke 1,6-A-Sicherung geschützt.

**Zubehör:** Anleitungen zur Installation enthält das jeweilige Handbuch.

ment ordinaire est disponible pour suppléer à un usage de plus de dix ans  
**Tension de sortie sous 1 k-ohm :** supérieure à 150 mV

**Tension d'alimentation :** + 11.5 à 28 V non-régulée

**Consommation en opération continue et en position d'attente :** inférieure à 125 mA

**Consommation au chauffage :** inférieure à 400 mA

**Usure :** inférieure à  $1.5 \times 10^{-9}/24$  h après 72 heures d'opération continue

**Déviations de température de 0° C à 50° C :** inférieure à  $3 \times 10^{-8}$  par rapport à + 25° C

**Déviations  $\pm 10\%$  tension secteur :** inférieure à  $5 \times 10^{-10}$

**Variation de la mesure et du mode d'alimentation :** inférieure à  $3 \times 10^{-9}$

**Temps de chauffage :** inférieure à 15 minutes pour atteindre  $1 \times 10^{-7}$

**Caractéristiques d'environnement :** Identiques à celles du compteur

**Dimensions :** 100  $\times$  52  $\times$  35 mm

**Poids :** 100 g

**Oscillateur à enceinte thermostatée PM 9691**

**Fréquence :** 10 MHz

**Gamme d'ajustement :** + 3 Hz et — 7 Hz avec réglage fin. Un dispositif d'ajustement ordinaire est disponible pour suppléer à un usage de plus de dix ans

**Tension de sortie sous 1 k-ohm :** supérieure à 150 mV

**Tension d'alimentation :** + 11.5 à 28 V non-régulée

**Consommation en opération continue et en position d'attente :** inférieure à 125 mA

**Consommation au chauffage :** inférieure à 400 mA

**Usure :** inférieure à  $1.5 \times 10^{-10}/24$  h après 72 heures d'opération continue

**Déviations de température de 0° C à 50° C :** inférieure à  $3 \times 10^{-9}$  par rapport à + 25° C

**Déviations  $\pm 10\%$  tension secteur :** inférieure à  $5 \times 10^{-10}$

**Variation de la mesure et du mode d'alimentation :** inférieure à  $3 \times 10^{-9}$

**Temps de chauffage :** inférieure à 15 minutes pour atteindre  $1 \times 10^{-7}$

**Caractéristiques d'environnement :** Identiques à celles du compteur

**Dimensions :** 100  $\times$  52  $\times$  35 mm

**Poids :** 100 g

**Adaptateur pour montage Rack**

**PM 9669/01 :** rack 19" pour un compteur

**PM 9669/02 :** rack 19" pour deux compteurs

**Batterie**

**PM 9673 :** batterie rechargeable pour montage interne

**Valise**

**PM 9672** : une malette pour le compteur et pour les cordons de mesure

**Unités interface de sortie**

**PM 9674** : unité de sortie BCD

**PM 9675** : convertisseur digital/analogique

**PM 9676** : unité interface bus

**Accessoires livrés avec l'appareil**

**Notice d'emploi et d'entretien**

**Cordon secteur**

**Couverture de protection pour panneau avant**

**4. Installation**

**Adaption secteur** : le compteur peut être adapté à deux gammes de tension secteur, de 100 à 130 V et de 200 à 260 V.

La gamme de fréquence est de 45 à 440 Hz.

A la livraison, l'appareil est adapté pour la gamme de 200 à 260 V.

Pour adapter à une gamme de 100 à 130 V, modifier les connexions du transformateur secteur conformément à la figure ci-dessous et coller une étiquette de "115 V" à la place de celle de "230 V".

**Mise à la terre** : La mise à la terre peut être effectuée selon deux façons ;

1. par une prise de protection terre sur le panneau arrière.

2. par le câble secteur à trois conducteurs enfilés dans une prise comportant une terre.

**Remarque** : il est recommandé de ne se servir que d'une de ces alternatives afin d'éviter les bruits de fond.

**Fusible** : un fusible thermique au transformateur secteur et un fusible de 1.6 A à action rapide protègent l'alimentation secteur.

**Options** : se référer aux instructions de l'installation pour chaque modèle.

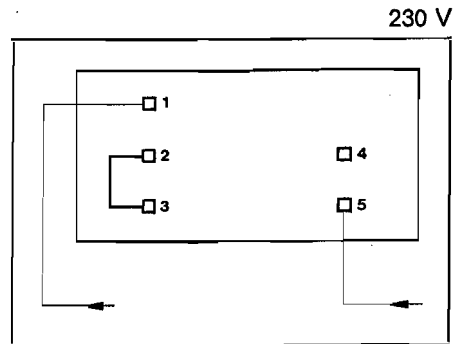
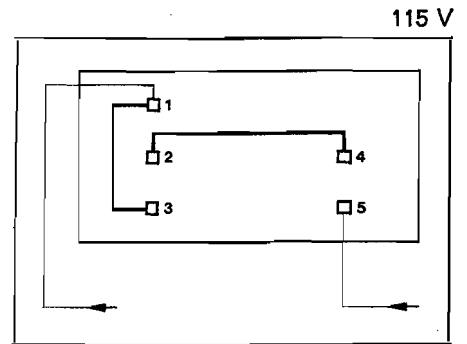

**Controls, indicators and connectors PM 6622**

**Bedienungsorgane, Indikatoren und Anschlüsse von PM 6622**

**Organes de commande, connecteurs et indicateurs PM 6622**

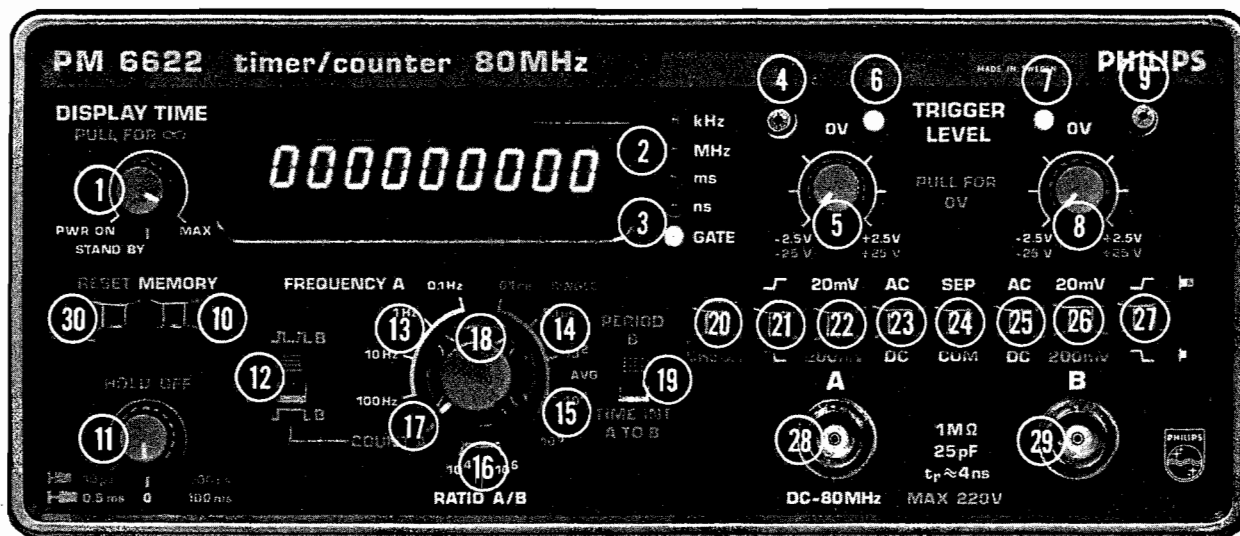

**1. Display time control:** Potentiometer sets display time between 0.2 s and 5 s. Infinite display time when knob is pulled. With switch set to position STAND BY the counter is turned off except of the oven oscillator.

**Warning:** Primary voltage of power supply is on.

**2. kHz, MHz, ms and ns:** Unit annunciators.

**3. Gate lamp:** Indicates that main-gate is opened and counting takes place, in the stand-by position the gate lamp indicates that the line voltage or battery is connected for X-tal oscillator stabilization.

**4. Monitor socket channel A:** Output socket for set trigger level.

**5. Trigger control channel A:** Sets trigger level from  $-2.5$  V to  $+2.5$  V when the attenuator is in position 20 mV, and from  $-25$  V to  $+25$  V when the attenuator is in position 200 mV. Knob pulled sets trigger level to 0 V.

**6. Trigger lamp channel A:** Tri-state control lamp for set trigger level. Blinking lamp indicates that the set trigger level matches the level of the input signal. Lamp permanently on indicates that the set trigger level is too high, and lamp turned off indicates that set trigger level is too low.

**7. Trigger lamp channel B:** Same as trigger lamp channel A.

**1. Anzeigzeit (Display time):** Potentiometer-Einstellung der Anzeigzeit zwischen 0,2 und 5 s. Unbegrenzte Anzeigzeit bei gezogenem Knopf. In Stellung STAND BY wird der Zähler mit Ausnahme des geheizten Oszillators abgeschaltet.

**Warnung:** Primärspannung des Netzteils ist eingeschaltet.

**2. kHz, MHz, ms und ns:** Anzeige der eingestellten Maßeinheit.

**3. Lampe GATE:** Zeigt, an, daß das Haupttor offen ist und eingezählt wird. In der Stellung STAND BY zeigt diese Lampe an, daß Netz oder Batterie angeschlossen sind, um den Kristalloszillator zu stabilisieren.

**4. Monitorbuchse Kanal A:** Ausgang für eingestellten Triggerpegel.

**5. Einstellung des Triggerpegels Kanal A:** Einstellung des Triggerpegels von  $-2,5$  V bis  $+2,5$  V (Abschwächer in Stellung 20 mV) oder von  $-25$  V bis  $+25$  V (Abschwächer in Stellung 200 mV). Durch Ziehen des Knopfes wird der Triggerpegel auf 0 V gestellt.

**6. Triggerlampe Kanal A:** Tristabile Anzeigelampe für den eingestellten Triggerpegel. Blinklicht zeigt an, daß der Triggerpegel auf Höhe des Eingangssignals liegt und eine Triggerung stattfindet. Leuchtet die Lampe dauernd, so ist der eingestellte Triggerpegel zu hoch, erlöscht sie ganz, ist er zu niedrig.

**7. Triggerlampe Kanal B:** Gleiche Funktion wie Triggerlampe Kanal A.

**1. Commande du temps d'affichage :** Ce potentiomètre règle le temps d'affichage entre 0,2 et 5 s. Le temps d'affichage infini est obtenu en tirant sur la commande. Avec le commutateur en position d'attente (STAND BY) le compteur est mis hors service, à l'exception de l'oscillateur à enceinte thermostatée.

**Attention :** La tension primaire de l'alimentation est en circuit !

**2. KHz, MHz, ms et ns :** Indicateurs d'unité.

**3. Lampe de porte :** Indique que la porte principale est ouverte et que le comptage a lieu. En position d'attente, la lampe de porte indique que la tension secteur ou batterie est appliquée en vue de la stabilisation de l'oscillateur cristal.

**4. Douille de contrôle de la voie A :** Douille de sortie pour le réglage du niveau de déclenchement.

**5. Commande de déclenchement pour voie A :** Règle le niveau de déclenchement de  $-2,5$  V à  $+2,5$  V avec l'atténuateur en position 20 mV, et de  $-25$  V à  $+25$  V avec l'atténuateur en position 200 mV. Le niveau de déclenchement est réglé sur 0 V en tirant sur la commande.

**6. Lampe de déclenchement pour voie A :** Lampe de contrôle (tri-state) du niveau de déclenchement réglé. Lorsque la lampe clignote, le niveau de déclenchement réglé correspond au niveau du signal d'entrée. Lorsque la lampe s'allume en permanence, le niveau est trop bas.



- 8. Trigger control channel B:** Same as trigger control channel A.
- 9. Monitor socket channel B:** Same as monitor socket channel A.
- 10. Memory:** In released position the measurement information is stored until next measurement cycle is completed. Depressed button makes display follow decade counters continuously.
- 11. Hold off control:** In Single Period Time Interval this control disables re-triggering of the main gate until the set hold off time is out.
- 12. Start/stop by B-Gated by B:** In the upper position it sets counter to measure Count A Start-Stop by B, in the lower position counter will measure Count A Gated by B.
- 13. Frequency A:** Sets counter to measure frequency at input A. 100 Hz, 10 Hz, 1 Hz and 0.1 Hz correspond to the resolution of the least significant digit.
- 14. Single:** Sets counter to measure Single Period B or Single Time Interval A to B. Time resolution can be set to 0.1 ms or 0.1  $\mu$ s.
- 15. Average:** Sets counter to measure Multiple Period B or Time Interval Average A to B.  $10^2$ ,  $10^4$  and  $10^6$  are number of averagings.
- 16. Ratio A/B:** Sets counter to measure ratio between signals at input A and B.  $10^4$  and  $10^6$  are multipliers.
- 17. Count A:** Sets counter to accumulate pulses between Start to Stop or Gated by B measurements.
- 18. Function selector:** Combined with the two slide switches it selects the different measuring modes.
- 19. Period B/Time interval A to B:** Sets counter to measure Period B or Time interval A to B.
- 20. Self check:** Connects 10 MHz from the internal oscillator to the input circuits of the counter.
- 21. Slope selector channel A:** Sets counter to trigger on either positive or negative slope of the input signal.
- 22. Attenuator channel A:** Provides  $10\times$  attenuation of the input signal.
- 23. AC/DC selector channel A:** Selects AC or DC coupling of the input signal.
- 8. Einstellung des Triggerpegels Kanal B:** Gleiche Funktion wie für Kanal A.
- 9. Monitorbuchse Kanal B:** Gleiche Funktion wie Monitorbuchse Kanal A.
- 10. MEMORY (Speicher):** In ausgelöster Stellung wird die Meßinformation bis Ende des nächsten Meßzyklus gespeichert. Bei eingedrückter Taste folgt die Anzeige kontinuierlich den Dekadenzählern.
- 11. HOLD OFF (Triggersperre):** Bei Messung von Einzelperiode und Einzel-Zeitintervall verhindert HOLD OFF die Triggerung des Haupttors vor Ablauf der eingestellten Haltezeit.
- 12. Start/Stopp und Torsteuerung durch B:** In der oberen Schalterstellung ist das Gerät auf Zählung A, Start/Stopp durch B eingestellt, in der unteren auf Zählung A und Torsteuerung durch B.
- 13. Frequenz A:** Einstellung des Zählers auf Frequenzmessungen an Eingang A; 100 Hz, 10 Hz, 1 Hz und 0,1 Hz bezeichnen die Auflösung der niedrigsten Stelle.
- 14. SINGLE:** Einstellung auf Messung von Einzelperiode B oder Einzel-Zeitintervall A-B. Zeitauflösung einstellbar auf 0,1 ms oder 0,1  $\mu$ s.
- 15. AVG (Mittelwert):** Einstellung auf Messung der Vielfachperiode B oder des Zeitintervall-Mittelwerts A-B. Anzahl der Meßperioden einstellbar auf  $10^2$ ,  $10^4$  und  $10^6$ .
- 16. RATIO A/B:** Zählereinstellung auf Verhältnismessung zwischen Signalen am Eingang A und Eingang B. Wählbare Multiplikatoren  $10^4$  und  $10^6$ .
- 17. COUNT A:** Einstellung des Zählers zum Summieren von Impulsen bei Start/Stopp oder Torsteuerung durch B.
- 18. Funktionswähler:** Zusammen mit den beiden Schiebeschaltern werden hier die verschiedenen Meßarten gewählt.
- 19. PERIOD B/TIME INTERVAL A TO B:** Einstellung des Zählers auf Messung von Periode B oder Zeitintervall A-B.
- 20. CHECK (Eigenkontrolle):** Verbindet 10-MHz-Signale vom internen Oszillator mit den Eingangskreisen des Zählers.
- 21. Flankenwählschalter Kanal A:** Einstellung der Triggerung auf negative oder positive Flanke des Eingangssignals.
- 22. Abschwächung Kanal A:** 10-fache Abschwächung des Eingangssignals.
- 7. Lampe de déclenchement pour voie B:** Identique à la lampe de déclenchement pour voie A.
- 8. Commande de déclenchement pour voie B:** Identique à la commande de déclenchement pour voie A.
- 9. Douille de contrôle pour voie B:** Identique à la douille de contrôle de la voie A.
- 10. Mémoire:** En position relâchée, l'information de mesure est stockée jusqu'à ce que le cycle de mesure suivant soit accompli. En position enfoncée, l'affichage suit continuellement les compteurs à décade.
- 11. Retard de déclenchement (HOLD OFF):** En mode période simple et intervalle de temps simple, cette commande empêche un déclenchement intempestif de la porte principale jusqu'à ce que le temps du retard de déclenchement soit écoulé.
- 12. Démarrage/arrêt par B/ Déclenchement par B:** En position supérieure, le compteur mesure le comptage A — démarrage/arrêt par B. En position inférieure, le compteur mesure le comptage A — déclenchement par B.
- 13. Fréquence A:** Positionne le compteur pour mesure de fréquence à l'entrée A. 100 Hz, 10 Hz, 1 Hz et 0.1 Hz correspondent à la résolution du chiffre le moins significatif.
- 14. Simple ("SINGLE"):** Positionne le compteur pour mesure de période simple B ou intervalle de temps simple A à B. La résolution de temps peut être réglée sur 0.1 ms ou 0.1  $\mu$ s.
- 15. Moyenne ("AVG."):**  Positionne le compteur pour mesure du périodemultiple B ou intervalle de temps moyen de A à B. Les moyennes  $10^2$ ,  $10^4$  et  $10^6$ , sont possibles.
- 16. Rapport A/B ("RATIO A/B"):** Positionne le compteur pour mesure du rapport entre les signaux d'entrée A et B. Les multiplicateurs  $10^4$  et  $10^6$  sont possibles.
- 17. Comptage A:** Positionne le compteur pour accumuler les impulsions entre les mesures démarrage-arrêt ou déclenchement par B.
- 18. Sélecteur de fonctions:** Combiné avec les deux commutateurs linéaires, il permet la sélection des différents modes de mesure.
- 19. Période B/ Intervalle de temps A à B ("PERIOD B/TIME INT. A TO B"):** Positionne le compteur pour mesure de période B, ou intervalle de temps A à B.
- 20. Auto Contrôle:** Connecte le 10 MHz de l'oscillateur interne aux circuits d'entrée du compteur.



- 24. Separate/Common via B:** Connects channel A and B internally in position COM VIA B. In position SEP the input channels are separated.
- 25. AC/DC selector channel B:** Same as AC/DC selector channel A.
- 26. Attenuator channel B:** Same as attenuator channel A.
- 27. Slope selector channel B:** Same as slope selector channel A.
- 28. Input A:** Input socket for frequency, ratio and time interval measurement.
- 29. Input B:** Input socket for period, ratio and time interval measurement.
- 30. Reset:** Resets counter and display to zero.
- 23. AC/DC-Wählschalter Kanal A:** Wahl von AC- oder DC-Kopplung des Eingangssignals.
- 24. SEP/COM über B:** In Stellung COM VIA B werden Kanal A und Kanal B intern verbunden. In Stellung SEP sind die beiden Eingangskanäle getrennt.
- 25. AC/DC-Wählschalter Kanal B:** Siehe AC/DC-Wählschalter Kanal A.
- 26. Abschwächung Kanal B:** Siehe Abschwächung Kanal A.
- 27. Flankenwählschalter Kanal B:** Siehe Flankenwählschalter Kanal A.
- 28. Eingang A:** Eingangsbuchse für Frequenz-, Verhältnis- und Zeitintervallmessungen.
- 29. Eingang B:** Eingangsbuchse für Perioden-, Verhältnis- und Zeitintervallmessungen.
- 30. RESET:** Rückstellung von Zähler und Anzeige auf Null.
- 21. Sélecteur de pente pour voie A:** Positionne le compteur pour déclencher sur pente positive ou négative du signal d'entrée.
- 22. Atténuateur pour voie A:** Fournit une atténuation  $10 \times$  du signal d'entrée.
- 23. Sélecteur AC/DC pour voie A:** Sélectionne le couplage capacitif ou continu du signal d'entrée.
- 24. Séparé/Commun par B ("SEP/COM"):** Connecte les voies A et B à l'intérieur en position COM VIA B. En position SEP, les voies d'entrée sont séparées.
- 25. Sélecteur AC/DC pour voie B:** Identique au sélecteur AC/DC pour voie A.
- 26. Atténuateur voie B:** Identique à l'atténuateur voie A.
- 27. Sélecteur de pente pour voie B:** Identique au sélecteur de pente pour voie A.
- 28. Entrée A:** Douille d'entrée pour mesure de fréquence, de rapport et d'intervalle de temps.
- 29. Entrée B:** Douille d'entrée pour mesure de période, de rapport et d'intervalle de temps.
- 30. Remise à zéro:** Remet le compteur et l'affichage à zéro.

Controls, indicators and connectors PM 6624 and PM 6625

Bedienungsorgane, Indikatoren und Anschlüsse von PM 6624 und PM 6625

Organes de commande, connecteurs et indicateurs PM 6624 et PM 6625

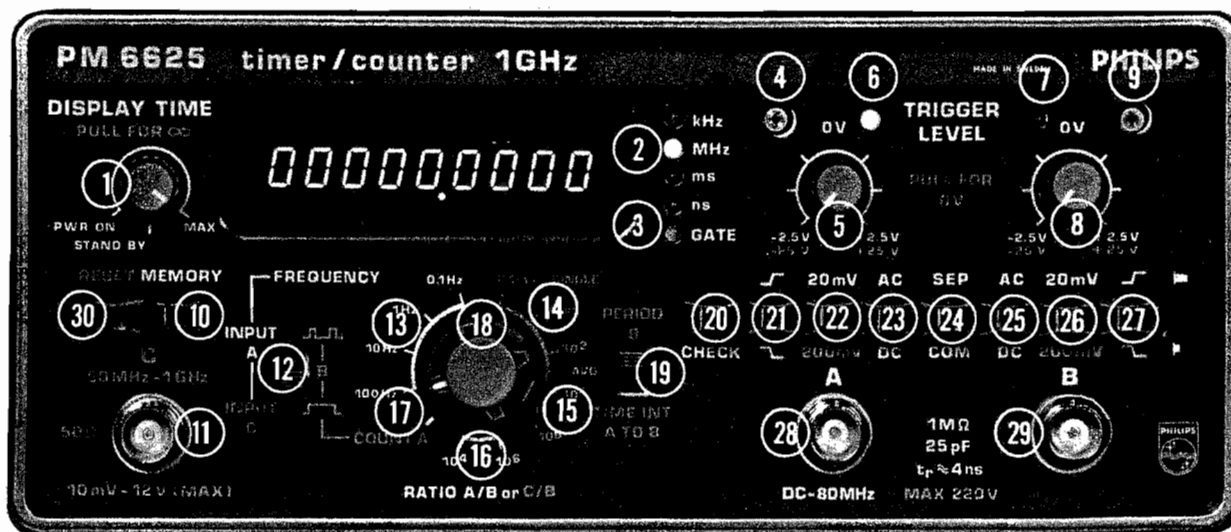

**1. Display time control:** Potentiometer sets display time between 0.2 and 5 s. Infinite display time when knob is pulled. With switch set to position STAND BY the counter is turned off except of the oven oscillator.

**Warning:** Primary voltage of power supply is on.

**2. kHz, MHz, ms and ns:** Unit annunciators.

**3. Gate lamp:** Indicates that main-gate is opened and counting takes place, in the stand-by position the gate lamp indicates that the line voltage or battery is connected for X-tal oscillator stabilization.

**4. Monitor socket channel A:** Output socket for set trigger level.

**5. Trigger control channel A:** Sets trigger level from  $-2.5$  V to  $+2.5$  V when the attenuator is in position 20 mV, and from  $-25$  V to  $+25$  V when the attenuator is in position 200 mV. Knob pulled sets trigger level to 0 V.

**6. Trigger lamp channel A:** Tri-state control lamp for set trigger level. Blinking lamp indicates that the set trigger level matches the level of the input signal. Lamp permanently on indicates that the set trigger level is too high, and lamp turned off indicates that set trigger level is too low.

**7. Trigger lamp channel B:** Same as trigger lamp channel A.

**1. Anzeigzeit (Display time):** Potentiometer-Einstellung der Anzeigzeit zwischen 0,2 und 5 s. Unbegrenzte Anzeigzeit bei gezogenem Knopf. In Stellung STAND BY wird der Zähler mit Ausnahme des geheizten Oszillators abgeschaltet.

**Warnung:** Primärspannung des Netzteils ist eingeschaltet.

**2. kHz, MHz, ms und ns:** Anzeige der eingestellten Maßeinheit.

**3. Lampe GATE:** Zeigt an, daß das Haupttor offen ist und eingezählt wird. In der Stellung STAND BY zeigt diese Lampe an, daß Netz oder Batterie angeschlossen sind, um den Kristalloszillator zu stabilisieren.

**4. Monitorbuchse Kanal A:** Ausgang für eingestellten Triggerpegel.

**5. Einstellung des Triggerpegels Kanal A:** Einstellung des Triggerpegels von  $-2,5$  V bis  $+2,5$  V (Abschwächer in Stellung 20 mV) oder von  $-25$  V bis  $+25$  V (Abschwächer in Stellung 200 mV). Durch Ziehen des Knopfes wird der Triggerpegel auf 0 V gestellt.

**6. Triggerlampe Kanal A:** Tristabile Anzeigelampe für den eingestellten Triggerpegel. Blinklicht zeigt an, daß der Triggerpegel auf Höhe des Eingangssignals liegt und eine Triggerung stattfindet. Leuchtet die Lampe dauernd, so ist der eingestellte Triggerpegel zu hoch, erlöscht sie ganz, ist er zu niedrig.

**1. Commande du temps d'affichage :** Ce potentiomètre règle le temps d'affichage entre 0.2 s et 5 s. On obtient le temps d'affichage infini en tirant sur la commande. En position d'attente (STAND BY) le compteur est mis hors service à — l'exception de l'oscillateur à enceinte thermostatée.

**Attention :** La tension primaire de l'alimentation est en circuit !

**2. KHz, MHz, ms et ns :** Indicateurs d'unité.

**3. Lampe de porte :** Indique que la porte principale est ouverte et que le comptage a lieu ; en position d'attente, la lampe de porte indique que la tension secteur ou batterie est appliquée en vue de la stabilisation de l'oscillateur cristal.

**4. Douille de contrôle de la voie A :** Douille de sortie pour le réglage du niveau de déclenchement.

**5. Commande de déclenchement pour voie A :** Règle le niveau de déclenchement de  $-2.5$  V à  $+2.5$  V avec atténuateur en position 20 mV et de  $-25$  V + 25 V avec atténuateur en position 200 mV. Le niveau de déclenchement est réglé sur 0 V en tirant sur ce bouton.

**6. Lampe de déclenchement pour voie A :** Lampe de contrôle (tri-state) du niveau de déclenchement réglé. Lorsque la lampe clignote, le niveau de déclenchement réglé correspond au niveau du signal d'entrée. Lorsque la lampe est allumée en permanence, le niveau de déclenchement est trop

- 8. Trigger control channel B:** Same as trigger control channel A.
- 9. Monitor socket channel B:** Same as monitor socket channel A.
- 10. Memory:** In released position the measurement information is stored until next measurement cycle is completed. Depressed button makes display follow decade counters continuously.
- 11. Input C:** Input socket for frequency and ratio measurement.
- 12. Start-Stop by B/Gated by B and Input A/Input C:** In the upper position it sets counter to measure Count A Start-Stop by B, Frequency A, or Ratio A/B and in the lower position it sets counter to measure Count A Gated by B, Frequency C or Ratio C/B depending on how the Function Selector is set.
- 13. Frequency A and C:** Sets counter to measure frequency at inputs A and C. 100 Hz, 10 Hz, 1 Hz and 0.1 Hz correspond to the resolution of the least significant digit.
- 14. Single:** Sets counter to measure Single Period B or Single Time Interval A to B. Time resolution can be set to 0.1 ms or 0.1  $\mu$ s.
- 15. Average:** Sets counter to measure Multiple Period B or Time Interval average A to B.  $10^2$ ,  $10^4$  and  $10^6$  are number of averagings.
- 16. Ratio A/B or C/B:** Combined with Input A/Input C switch it selects Ratio A/B or Ratio C/B measurement.  $10^4$  and  $10^6$  are multipliers.
- 17. Count A:** Sets counter to accumulate pulses between Start to Stop or Gated by B measurements.
- 18. Function selector:** Combined with the two slide switches it selects the different measuring modes.
- 19. Period B/Time interval A to B:** Sets counter to measure Period B or Time interval A to B.
- 20. Self check:** Connects 10 MHz from the internal oscillator to the input circuits of the counter.
- 21. Slope selector channel A:** Sets counter to trigger on either positive or negative slope of the input signal.
- 22. Attenuator channel A:** Provides  $10\times$  attenuation of the input signal.
- 7. Triggerlampe Kanal B:** Gleiche Funktion wie Triggerlampe Kanal A.
- 8. Einstellung des Triggerpegels Kanal B:** Gleiche Funktion wie für Kanal A.
- 9. Monitorbuchse Kanal B:** Gleiche Funktion wie Monitorbuchse Kanal A.
- 10. MEMORY (Speicher):** Bei gelöster Taste wird die Meßinformation bis Ende des nächsten Meßzyklus gespeichert. Bei eingedrückter Taste folgt die Anzeige kontinuierlich den Dekadenzählern.
- 11. Eingang C:** Eingangsbuchse für Frequenz- und Verhältnismessung.
- 12. Start/Stopp und Torsteuerung durch B sowie INPUT A/INPUT C:** In der oberen Schalterstellung ist das Gerät auf Zählung A (Start/Stopp durch B), Frequenz A oder Verhältnis A/B eingestellt. In der unteren Schalterstellung hingegen auf Zählung A (Torsteuerung durch B), Frequenz C oder Verhältnis C/B — je nach Einstellung des Funktionswählers.
- 13. Frequenz A und C:** Einstellung auf Frequenzmessungen an den Eingängen A und C; 100 Hz, 10 Hz, 1 Hz und 0,1 Hz bezeichnen die Auflösung der niedrigsten Stelle.
- 14. SINGLE:** Einstellung auf Messung der Einzelperiode B oder des Einzelzeitintervalls A-B. Zeitauflösung einstellbar auf 0,1 ms oder 0,1  $\mu$ s.
- 15. AVG (Mittelwert):** Einstellung auf Messung der Vielfachperiode B oder des Zeitintervall-Mittelwerts A-B. Anzahl der Meßperioden einstellbar auf  $10^2$ ,  $10^4$  und  $10^6$ .
- 16. RATIO A/B or C/B:** Zusammen mit dem Schalter INPUT A/INPUT C wird hier zwischen Verhältnismessung A/B oder C/B gewählt.  $10^4$  und  $10^6$  sind wählbare Multiplikatoren.
- 17. COUNT A:** Einstellung des Zählers zum Summieren von Impulsen bei Start/Stopp oder Torsteuerung durch B.
- 18. Funktionswähler:** Zusammen mit den beiden Schiebeschaltern werden hier die verschiedenen Meßarten gewählt.
- 19. PERIOD B/TIME INTERVAL A TO B:** Einstellung des Zählers auf Messung von Periode B oder Zeitintervall A-B.
- 20. CHECK (Eigenkontrolle):** Verbindet 10-MHz-Signale vom internen Oszillator mit den Eingangskreisen des Zählers.
- élevé, par contre, si la lampe s'éteint ce niveau est trop bas.
- 7. Lampe de déclenchement pour voie B:** Identique à la lampe de déclenchement pour voie A.
- 8. Commande de déclenchement pour voie B:** Identique à la commande de déclenchement pour voie A.
- 9. Douille de contrôle de la voie B:** Identique à la douille de contrôle de la voie A.
- 10. Mémoire:** En position relâchée, l'information de mesure est stockée jusqu'à ce que le cycle de mesure suivant soit accompli. En position enfoncée, l'affichage suit continuellement les compteurs à decade.
- 11. Entrée C:** Douille d'entrée pour mesure de fréquence et de rapport.
- 12. Démarrage/Arrêt par B/Déclenchement par B et Entrée A/Entrée C:** En position supérieure, le compteur mesure le comptage A — démarrage/arrêt par B, la fréquence ou le rapport A/B. En position inférieure, le compteur mesure le comptage A — déclenchement par B, la fréquence C ou le rapport C/B selon la position du sélecteur de fonctions.
- 13. Fréquence A et C:** Positionne le compteur pour mesurer la fréquence aux entrées A et C. 100 Hz, 10 Hz, 1 Hz et 0.1 Hz correspondent à la résolution du chiffre le moins significatif.
- 14. Simple (SINGLE):** Positionne le compteur pour mesurer la période simple B, ou l'intervalle de temps simple de A à B. La résolution de temps peut être réglée sur 0.1 ms ou 0.1  $\mu$ s.
- 15. Moyenne (AVG.):** Positionne le compteur pour mesurer la période multiple B, ou la moyenne de l'intervalle de temps A à B,  $10^2$ ,  $10^4$  et  $10^6$ , sont le nombre de moyennes possibles.
- 16. Rapport A/B ou C/B:** Combinée avec entrée A/entrée C, cette position permet de mesurer le — rapport A/B ou le rapport C/B. Les multiplicateurs  $10^4$  et  $10^6$  sont possibles.
- 17. Comptage A:** Positionne le compteur pour accumuler les impulsions entre les mesures démarrage — arrêt ou déclenchement par B.
- 18. Sélecteur de fonctions:** Combiné avec les deux commutateurs à coulisse, il sélectionne les différents modes de mesure.
- 19. Période B/Intervalle de temps A à B ("PERIOD B/ TIME INT. A TO B"):** Positionne le compteur pour mesurer la période B ou l'intervalle de temps — A à B.

- 23. AC/DC selector channel A:** Selects AC or DC coupling of the input signal.
- 24. Separate/Common via B:** Connects channel A and B internally in position COM VIA B. In position SEP the input channels are separated.
- 25. AC/DC selector channel B:** Same as AC/DC selector channel A.
- 26. Attenuator channel B:** Same as attenuator channel A.
- 27. Slope selector channel B:** Same as slope selector channel A.
- 28. Input A:** Input socket for frequency, ratio and time interval measurement.
- 29. Input B:** Input socket for period, ratio and time interval measurement.
- 30. Reset:** Resets counter and display to zero.
- 21. Flankenwählschalter Kanal A:** Einstellung der Triggerung auf negative oder positive Flanke des Eingangssignals.
- 22. Abschwächung Kanal A:** 10-fache Abschwächung des Eingangssignals.
- 23. AC/DC-Wählschalter Kanal A:** Wahl von AC- oder DC-Kopplung des Eingangssignals.
- 24. SEP/COM über B:** In Stellung COM VIA B werden Kanal A und Kanal B intern verbunden. In Stellung SEP sind die beiden Eingangskanäle getrennt.
- 25. AC/DC-Wählschalter Kanal B:** Siehe AC/DC-Wählschalter Kanal A.
- 26. Abschwächung Kanal B:** Siehe Abschwächung Kanal A.
- 27. Flankenwählschalter Kanal B:** Siehe Flankenwählschalter Kanal A.
- 28. Eingang A:** Eingangsbuchse für Frequenz-, Verhältnis- und Zeitintervallmessungen.
- 29. Eingang B:** Eingangsbuchse für Perioden-, Verhältnis- und Zeitintervallmessungen.
- 30. RESET:** Rückstellung von Zähler und Anzeige auf Null.
- 20. Auto Contrôle:** Connecte le 10 MHz de l'oscillateur interne aux circuits d'entrée du compteur.
- 21. Sélecteur de pente pour voie A:** Positionne le compteur pour déclencher sur la pente positive ou négative du signal d'entrée.
- 22. Atténuateur voie A:** Fournit une atténuation  $10 \times$  du signal d'entrée.
- 23. Sélecteur AC/DC pour voie A:** Sélectionne le couplage capacitif ou continu du signal d'entrée.
- 24. Séparé/Commun par B ("SEP/COM"):** Connecte les voies A et B à l'intérieur en position COM VIA B. En position SEP, les voies d'entrée sont séparées.
- 25. Sélecteur AC/DC pour voie B:** Identique au sélecteur AC/DC pour voie A.
- 26. Atténuateur pour voie B:** Identique à l'atténuateur pour voie A.
- 27. Sélecteur de pente pour voie B:** Identique au sélecteur de pente pour voie A.
- 28. Entrée A:** Douille d'entrée pour mesure de fréquence, de rapport et d'intervalle de temps.
- 29. Entrée B:** Douille d'entrée pour mesure de période, de rapport et d'intervalle de temps.
- 30. Remise à zéro:** Remet le compteur et l'affichage à zéro.

## Controls and connectors

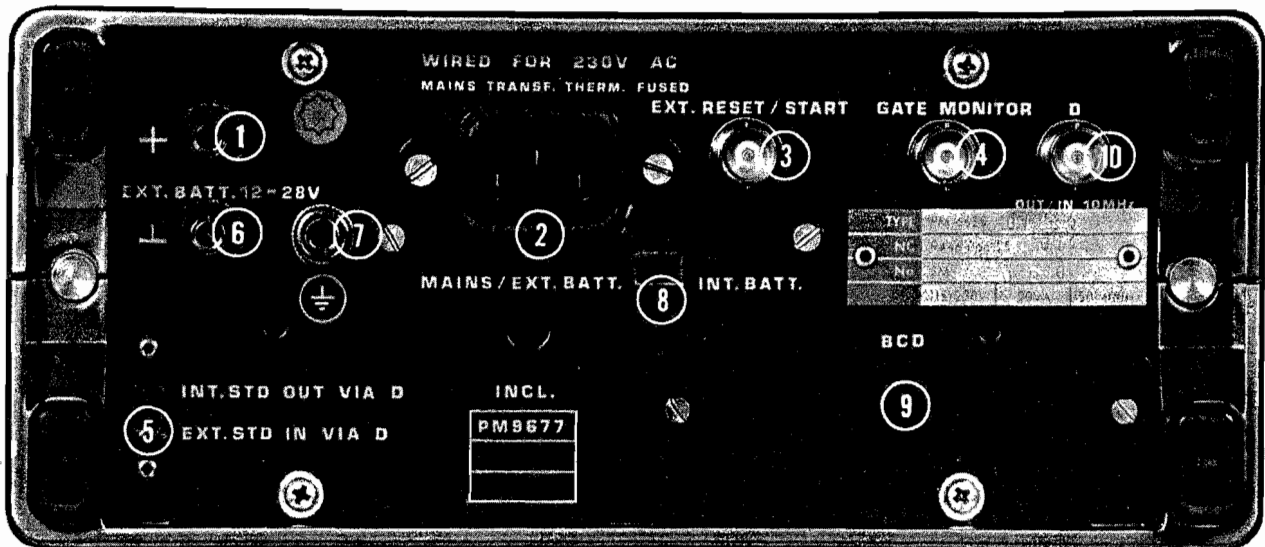
Bedienungsorgane  
und AnschlüsseOrganes de commande  
et connecteurs

1. External battery socket: Plus pole input socket for external battery.

2. Mains input: Input socket for the mains.

3. External reset input: Input socket for reset/start signal.

4. Monitor socket gate signal: Output socket for gate and hold off (PM 6622) signals.

5. Internal/External Standard switch: Sets operating mode of input D to either internal 10 MHz out or external 10 MHz in.

6. External battery socket: Minus pole input socket for external battery.

7. Chassis ground: Protective earth terminal.

8. Mains/Battery switch: Sets power supply to be fed from external or internal power source.

9. BCD and D/A connector: Output connector for the BCD and D/A units.

10. Internal/External Standard socket: 10 MHz out or external 10 MHz in.

1. Buchse für externe Batterie: Pluspol zum Anschluß der externen Batterie.

2. Netzeingang: Anschluß des Netzkabels.

3. Buchse für externe Rückstellung: Eingang für externe Rückstell-/Startsignale.

4. Monitorbuchse für Torsignale: Ausgang für Tor- und HOLD OFF-Signale (letztere nur PM 6622).

5. Schalter INT. STD./EXT. STD.: Einstellung der Betriebsart von Eingang D auf interne 10 MHz oder externe 10 MHz.

6. Buchse für externe Batterie: Minuspol zum Anschluß der externen Batterie.

7. Gehäuseerdung: Schutzerdungsklemme.

8. Umschalter Netz/Batterie: Einstellung auf Netz- oder Batteriespeisung des Geräts.

9. Buchse für BCD und D/A: Ausgang für BCD-Steckkarte oder D/A-Wandler.

10. Buchse für internen/externen Standard: 10-MHz-Ausgang oder externer 10-MHz-Eingang.

1. Douille pour batterie externe: Douille d'entrée à pôle positif pour batterie externe.

2. Entrée secteur: Douille d'entrée secteur.

3. Entrée de remise à zéro externe: Douille d'entrée pour remise à zéro/signal de démarrage.

4. Douille de contrôle pour signal de porte: Douille de sortie pour — signaux de porte et de retard de déclenchement (PM 6622).

5. Commutateur standard interne/externe: Commute soit l'oscillateur interne, soit l'oscillateur externe, avec entrée ou sortie de la fréquence 10 MHz, sur la douille D.

6. Douille pour batterie externe: Douille d'entrée à pôle négatif, pour batterie externe.

7. Prise de terre: Protection terre.

8. Commutateur secteur/batterie: Règle l'alimentation pour source interne ou externe.

9. Connecteur BCD et D/A: Connecteur de sortie pour unités BCD et D/A.

10. Douille standard interne/externe: Sortie du signal 10 MHz, ou entrée du signal 10 MHz externe.

## Operation

**Mains:** Before the counter is connected to the mains check that the mains transformer is wired for the local mains voltage as described in chapter Installation.

— Set switch MAINS EXT. BATT/INT. BATT on the rear panel to position MAINS EXT. BATT.

— Connect the mains cable to input socket for the mains at the rear panel.

— Set DISPLAY TIME control at the front panel to position ON.

— Check that display turns on indicating that power is on.

**External battery:** Set switch MAINS EXT. BATT/INT. BATT at the rear panel to position MAINS EXT. BATT.

— Connect the cables from the external battery to sockets EXT. BATT. 12—28 V at the rear panel.

— Set DISPLAY TIME at the front panel control to position ON.

— Check that display turns on indicating that power is on.

**Internal battery PM 9673:** Set switch MAINS EXT. BATT/INT. BATT. at the rear panel to position INT. BATT.

— Set DISPLAY TIME control at the front panel to position ON.

— Check that display turns on indicating that power is on. Blinking display indicates low voltages. Refer to manual PM 9673 for charging instructions.

**Warm up time:** The warm up time from the moment of mains connection is less than 7 minutes to an oscillator error of less than  $10^{-7}$  for instruments equipped with the oven enclosed oscillator PM 9690. Instruments equipped with the oscillators PM 9677 or PM 9678 (TCXO) are ready for use at the moment of mains connection.

Normally the instrument is switched on from the STAND BY position. If so, no warm up time is needed, irrespective of which oscillator is employed.

**External frequency standards:** House standards or other frequency standards can be used instead of the internal 10 MHz oscillator.

If a time resolution of 100 ns is required, 10 MHz must be used. When using 1 MHz instead of 10 MHz the decimal point must be shifted one step to the left to interpret the display correctly. To set the counter to external standard the switch INT. STD OUT VIA D/EXT. STD IN VIA D at the rear panel must be set to position EXT. STD IN VIA D.

## Betrieb

**Netzanschluß:** Vor Anschluß des Zählers an das Netz überzeuge man sich, daß der Netztrafo der örtlichen Spannung entsprechend verdrahtet ist (vgl. Abschnitt „Installation“).

— Schalter MAINS EXT. BATT/INT. BATT auf der Rückseite des Geräts auf MAINS EXT. BATT stellen.

— Netzkabel auf der Rückseite einstecken.

— Einsteller DISPLAY TIME auf ON stellen.

— Kontrollieren, ob die Anzeige aufleuchtet und das Gerät somit eingeschaltet ist.

**Externe Batterie:** Schalter MAINS EXT. BATT/INT. BATT auf der Rückseite des Geräts auf MAINS EXT. BATT stellen.

— Anschlußkabel der externen Batterie in die Buchsen EXT. BATT 12—28 V auf der Rückseite stecken.

— Einsteller DISPLAY TIME auf ON stellen.

— Kontrollieren, ob die Anzeige aufleuchtet und das Gerät somit eingeschaltet ist.

**Interne Batterie PM 9673:** Schalter MAINS EXT. BATT/INT. BATT auf der Geräterückseite auf INT. BATT stellen.

— Einsteller DISPLAY TIME auf ON stellen.

— Kontrollieren, ob die Anzeige aufleuchtet und das Gerät somit eingeschaltet ist. Blinkende Anzeige bedeutet zu niedrige Spannung. Anweisungen zur Aufladung der Batterie enthält das Handbuch PM 9673.

**Aufwärmzeit:** Die Aufwärmzeit vom Netzanschluß bis zur Erreichung einer Oszillator-Fehlergrenze von unter  $10^{-7}$  beträgt bei Geräten mit dem geheizten Oszillator PM 9690 weniger als 7 Minuten. Zähler mit den Oszillatoren PM 9677 oder PM 9678 (TCXO) sind sofort nach Netzanschluß betriebsbereit.

Gewöhnlich wird das Instrument aus der Stellung STAND BY eingeschaltet. In diesem Fall ist keine Aufwärmzeit erforderlich, gleichgültig welcher Oszillator verwendet wird.

**Externe Frequenzstandards:** Anstelle des 10-MHz-Oszillators können auch andere Frequenzstandards verwendet werden.

Um eine Zeitauflösung von 100 ns zu erreichen, sind jedoch 10 MHz unbedingt erforderlich. Bei Verwendung von

## Mise en service

**Secteur :** Avant de brancher le compteur au secteur, vérifier si le — transformateur secteur est connecté pour la tension secteur locale, comme décrit au chapitre INSTALLATION.

— Mettre le commutateur MAINS EXT. BATT/INT. BATT du panneau arrière, en position MAINS EXT. BATT.

— Connectez le câble secteur à la douille d'entrée secteur à l'arrière.

— Réglez la commande DISPLAY TIME (panneau avant) sur position ON.

— Vérifier si l'affichage s'allume, indiquant ainsi que l'appareil est branché.

**Batterie externe :** Mettre le commutateur MAINS EXT. BATT/INT. BATT (panneau arrière) en position MAINS EXT. BATT.

— Connecter les câbles de la batterie externe aux douilles EXT. BATT. 12—28 V (panneau arrière).

— Mettre la commande DISPLAY TIME (panneau avant) en position ON.

— Vérifier si l'affichage s'allume, indiquant ainsi que l'appareil est branché.

**Batterie interne PM 9673 :** Mettre le commutateur MAINS EXT. BATT/INT. BATT (panneau arrière) en position INT. BATT.

— Mettre la commande DISPLAY TIME (panneau avant) en position ON.

— Vérifier que l'affichage s'allume, indiquant ainsi que l'appareil est branché. Si l'affichage clignote, cela signifie que les batteries sont presque déchargées. Voir la notice PM 9673 pour instructions de charge.

**Temps de chauffage :** Le temps de chauffage à partir du branchement au secteur est inférieur à 7 minutes avec erreur de l'oscillateur inférieure à  $10^{-7}$ , lorsque les compteurs sont équipés de l'oscillateur à enceinte thermostatée PM 9690. Les appareils équipés des oscillateurs PM 9677 ou PM 9678 (TCXO) sont prêts à l'usage dès le branchement au secteur.

Normalement, l'appareil est enclenché en position d'attente (STAND BY). Dans ce cas, le temps de chauffage n'est pas nécessaire, quelque soit l'oscillateur utilisé.

**Étalons de fréquence externe :** Des étalons de fréquence externe peuvent être utilisés à la place de l'oscillateur interne 10 MHz.

Pour une résolution de temps de 100 ns, l'oscillateur à 10 MHz doit être utilisé. En cas d'application de 1 MHz au lieu de 10 MHz, le point décimal doit

**A, B and C inputs:** The A and B amplifiers are identical in specification and provided with identical input controls. The A input is normally used for frequency measurement and the B input for time measurement.

The C input is a prescaler input with automatic PIN-diode attenuator and mainly used for high frequency measurement.

**ac and dc coupling:** The ac/dc push-button controls the coupling of the input signal to the attenuator and the amplifier by switching a capacitor in series in the ac mode and by direct coupling in the dc mode.

ac coupling is normally used to block the dc component in signals which are superimposed on a ac voltage. The capacitor in series will, however, cause a falling sensitivity for low frequencies. In waveforms where pulse width and repetition time vary the dc level will also vary. Change in the dc level will cause changes in the preset triggering level and make accurate time measurements impossible if ac coupled, in such cases the input should be dc coupled. Normally frequency measurements are performed with an ac coupled input and time interval measurements with a dc coupled input.

**Attenuator and Trigger Level:** The TRIGGER LEVEL control allows continuous setting of the trigger level at any point of the input signal. For high amplitude signals the attenuator is used to expand the setting range. However, input attenuation will decrease the sensitivity and cause bigger trigger errors.

For frequency measurements on sine wave and other symmetrical signals no level off-set is required. Pulled position of the TRIGGER LEVEL control sets the trigger level to 0 V for highest sensitivity.

However, for frequency measurement on narrow pulses a limited off-set voltage may be needed to obtain reliable triggering.

Time measurement requires continuously variable setting of the trigger level.

Monitor sockets for channel A and B provide the ability to measure the set trigger level.

If the attenuator is set to 200 mV the trigger level range is increased 10 times from  $\pm 2.5$  V to  $\pm 25$  V.

The name trigger level can be misleading, since triggering does not occur on the set trigger level but at the trigger point.

1 MHz anstelle von 10 MHz ist der Dezimalpunkt um eine Stelle nach links zu verschieben, um die Anzeige korrekt abzulesen. Um den Zähler auf ein externes Standardsignal einzustellen, ist der Schalter INT. STD. OUT VIA D/EXT. STD. IN VIA D in die Stellung EXT. STD. IN VIA D zu bringen.

**Eingänge A, B und C:** Die Verstärker A und B sind den Kenngrößen und Eingangsreglern nach identisch. Der Eingang A wird gewöhnlich für Frequenzmessungen verwendet, der Eingang B für Zeitmessungen. Der Eingang C ist ein Vorteilereingang mit automatischem PIN-Dioden-Abschwächer und wird vorzugsweise zum Messen hoher Frequenzen verwendet.

**AC- und DC-Kopplung:** Die Drucktaste AC/DC regelt die Kopplung des Eingangssignals mit dem Abschwächer und dem Verstärker durch Serienschaltung eines Kondensators im AC-Betrieb bzw. Direktkopplung im DC-Betrieb.

Die AC-Kopplung wird gewöhnlich verwendet, um die Gleichspannungskomponente von Signalen, die einer Wechselspannung überlagert sind, zu unterdrücken. Der seriengeschaltete Kondensator verursacht jedoch eine Abnahme der Empfindlichkeit bei niedrigen Frequenzen. Bei Signalformen mit wechselnder Impulsbreite und Wiederholzeit wechselt auch der Gleichspannungspegel. Veränderungen des Gleichspannungspegels führen wiederum zu Schwankungen des voreingestellten Triggerpegels und machen, falls AC-gekoppelt, genaue Zeitmessungen unmöglich. In solchen Fällen sollte der Eingang DC-gekoppelt sein. Normalerweise werden Frequenzmessung mit AC-gekoppeltem Eingang und Zeitintervallmessungen mit DC-gekoppeltem Eingang durchgeführt.

**Abschwächer und Triggerpegel:** Mit dem Potentiometer TRIGGER LEVEL läßt sich der Triggerpegel stufenlos auf jeden beliebigen Punkt des Eingangssignals einstellen. Bei hohen Amplituden wird ein Abschwächer verwendet, um den Einstellbereich zu erweitern. Eingangsdämpfung vermindert jedoch die Empfindlichkeit und verursacht größere Triggerfehler.

Für Frequenzmessungen an sinusförmigen und anderen symmetrischen Signalen ist kein Pegel-Offset erforderlich. Durch Ziehen des Knopfes TRIGGER LEVEL wird der Triggerpegel auf

être décalé d'une unité vers la gauche, afin d'interpréter — correctement l'affichage. Pour régler le compteur sur étalon externe, régler le commutateur INT. STD OUT VIA D/EXT. STD IN VIA D en position — EXT. STD IN VIA D.

**Entrées A, B et C :** Les amplificateurs A et B sont identiques en spécification et pourvus des mêmes commandes d'entrée.

L'entrée A est normalement utilisée pour la mesure de fréquence, et l'entrée B pour la mesure de temps.

L'entrée C est une entrée de pré-étaionnage avec atténuateur automatique à diodes PIN et utilisée principalement pour la mesure de haute fréquence.

**Couplages capacitif et continu :** Les boutons-poussoirs AC/DC contrôlent le couplage du signal d'entrée vers l'atténuateur et l'amplificateur en commutant un condensateur en série en mode AC (capacitif) et par couplage direct en mode DC (continu). Le couplage capacitif est normalement utilisé pour bloquer les — composantes continues dans les signaux superposés à une tension alternatif quoique le condensateur en série fasse décroître la sensibilité à basse fréquence.

Les formes d'onde à largeur d'impulsion et de temps de répétition variables présentent également un niveau continu variable.

Lorsque le niveau continu varie, le niveau de déclenchement pré-réglé varie également et rend les mesures de temps imprécises en couplage — capacitif. Dans de tels cas, l'entrée doit être couplée en continu. Normalement les mesures de fréquence sont effectuées avec une entrée en couplage capacitif, et les mesures d'intervalle de temps avec une entrée en couplage continu.

**Atténuateur et niveau de déclenchement :** La commande TRIGGER LEVEL permet le réglage continu du niveau de déclenchement en tout point du signal d'entrée. Pour les signaux à haute amplitude, l'atténuateur sert à étendre la gamme de réglage.

Cependant, l'atténuation d'entrée fait décroître la sensibilité et entraîne des erreurs de déclenchements plus importantes.

Pour des mesures de fréquence sur onde sinusoïdale et d'autres signaux symétriques, aucun offset de niveau n'est requis.

Le niveau de déclenchement est réglé



**Separate and Common via B mode:** In the SEP position the A and B inputs operate independently of each other in any operations irrespective of input sources. In the COM position the A input is disconnected from its attenuator and amplifier, and a signal connected to input B is coupled to both A and B attenuators and amplifiers. All input specifications of input B will remain the same but the input impedance will be 500 k $\Omega$  shunted by 50 pF.

**Positive and negative slope triggering:** This push-button determines on which slope of the input signal the triggering will occur.

In released position the triggering will occur at the positive slope of the input signal and in depressed position it will occur on the negative slope.

Where on the slope the triggering will occur is determined by the TRIGGER LEVEL control.

A simple way to measure the pulse width of a positive pulse is achieved by setting input A to positive slope and input B to negative slope, connect the pulse to input B, set FUNCTION SELECTOR to any of the two SINGLE positions, slide switch PERIOD B/TIME INT. A TO B to position TIME INT. A TO B and SEP/COM to COM.

**Hold off PM 6622:** This control provides a delayed triggering of the instrument in single period and time interval measurement, this feature is used to avoid false triggering on noisy signals.

0 V für höchste Empfindlichkeit eingestellt.

Für Frequenzmessungen an schmalen Impulsen kann jedoch eine begrenzte Offset-Spannung erforderlich sein, um eine verlässliche Triggerung zu erreichen.

Für Zeitmessungen ist eine stufenlos variable Einstellung des Triggerpegels erforderlich.

Mit Hilfe der Monitorbuchsen für Kanal A und B läßt sich der eingestellte Triggerpegel messen.

Durch Einstellung des Abschwächers auf 200 mV wird der Triggerpegelbereich zehnfach erweitert, von  $\pm 2,5$  auf  $\pm 25$  V.

Die Bezeichnung Triggerpegel mag hier irreführend sein, da die Triggerung nicht am eingestellten Triggerpegel erfolgt, sondern am Triggerpunkt.

**Schaltart SEP (getrennt) und COM (gemeinsam) über B:** In Stellung SEP arbeiten die Eingänge A und B in jeder Betriebsart unabhängig voneinander, ungeachtet der Signalquellen. In Stellung COM ist der Eingang A von seinem Abschwächer und Verstärker getrennt, und das Signal am Eingang B wird an die Abschwächer und Verstärker beider Kanäle (A und B) gekoppelt. Alle Kenngrößen von Eingang B bleiben unverändert, doch beträgt die Eingangsimpedanz 500 k $\Omega$ , geschuntet mit 50 pF.

**Triggerung auf positiver und negativer Flanke:** Mit dieser Drucktaste wird die gewünschte Triggerflanke gewählt. Bei gelöster Taste erfolgt die Triggerung auf der positiven Flanke des Eingangssignals, bei gedrückter Taste auf der negativen Flanke.

An welchem Punkt die Triggerung erfolgt, hängt von der Einstellung des Stellknopfes TRIGGER LEVEL ab.

Die Breite eines positiven Impulses läßt sich auf einfache Weise wie folgt messen: Eingang A auf positive Flanke und Eingang B auf negative Flanke einstellen, Impuls an Eingang B legen, Funktionswähler auf eine der beiden SINGLE-Funktionen, Schiebeschalter PERIOD B/TIME INT. A TO B auf TIME INT. A TO B sowie SEP/COM auf COM stellen.

**Hold off (PM 6622):** Dieser Einsteller ermöglicht eine verzögerte Triggerung des Geräts bei der Messung von Einzelperioden und Zeitintervallen. Dadurch werden Fehltriggerungen bei veräuschten Signalen vermieden.

sur 0 V pour une plus haute — sensibilité, en tirant sur la commande TRIGGER LEVEL.

Cependant, pour la mesure de fréquence en impulsions étroites une tension d'offset limitée peut être requise afin d'obtenir un déclenchement fiable. La mesure de temps requiert un réglage continuellement variable du niveau de déclenchement.

Les douilles de contrôle pour les voies A et B permettent de mesurer le niveau de déclenchement exact.

Si l'atténuateur est réglé sur 200 mV, la gamme du niveau de déclenchement est accrue de 10 fois de  $\pm 2,5$  V à  $\pm 25$  V.

La dénomination "niveau de déclenchement" peut sembler abusive, car le déclenchement n'a pas lieu au niveau de déclenchement réglé, mais au point de déclenchement.

**Modes d'entrée Séparée et Commune par B :** En position SEP les entrées A et B fonctionnent indépendamment l'une de l'autre sans tenir compte des fonctions, ni des sources d'entrée. En position COM, l'entrée A est déconnectée de son atténuateur et de son amplificateur, et un signal connecté à l'entrée "B" est couplé aux atténuateurs et amplificateurs A et B.

Toutes les spécifications d'entrée B restent identiques, si ce n'est que l'impédance d'entrée qui est de 500 k $\Omega$  déviée à travers 50 pF.

**Déclenchement sur pente positive et négative :** Ce bouton-poussoir détermine sur quelle pente du signal d'entrée, aura lieu le déclenchement.

En position relâchée le déclenchement a lieu sur la pente positive du signal d'entrée, et en position enfoncée, le déclenchement a lieu sur la pente négative.

Le point de déclenchement est déterminé par la commande TRIGGER LEVEL. La largeur d'une impulsion positive peut être mesurée en réglant l'entrée A sur pente positive et l'entrée B sur pente négative, connecter ensuite l'impulsion à l'entrée B, régler le sélecteur de fonctions sur une des deux positions SINGLE, coulisser le commutateur PERIOD B/TIME INT. A TO B en position TIME INT. A TO B et SEP/COM sur COM.

**Retard de déclenchement sur PM 6622 :** Cette commande permet le déclenchement retardé de l'appareil pour mesure de période simple et d'intervalle de temps, et ce afin d'éviter un faux déclenchement sur des signaux bruités.



### Period B

Simple period measurement on sine waves and other symmetrical waveforms.

- Set FUNCTION SELECTOR to SINGLE or AVG measurement
  - Set PERIOD B/TIME INT. A TO B to PERIOD B
  - Pull TRIGGER LEVEL
  - Set AC/DC to AC
  - Set 20 mV/200 mV to 200 mV if the amplitude of the input signal is higher than  $1 V_{rms}$
  - Select positive slope triggering
  - Connect the signal to input B
- Display will show period time in ms or ns

### Time Interval A to B

Simple measurement of time interval between pulses at input A and B from separate sources.

- Set FUNCTION SELECTOR to SINGLE or AVG
  - Set PERIOD B/TIME INT. A TO B to TIME INT. A TO B
  - Set 20 mV/200 mV to 200 mV if the amplitude of the input signal is higher than  $3 V_{p-p}$
  - Set AC/DC to DC
  - Set SEP/COM to SEP
  - Select positive slope triggering
  - Set TRIGGER LEVEL potentiometer to suitable trigger level e.g. 50 % of the pulse amplitude
  - Connect the pulses to input A and B
- Display will show the time interval in ms or ns

### Ratio A/B

Simple ratio measurement on sine wave or other symmetrical waveforms.

- Set FUNCTION SELECTOR to  $10^4$  or  $10^6$
  - Pull TRIGGER LEVEL control
  - Set AC/DC to AC
  - Set SEP/COM to SEP
  - Set 20 mV/200 mV to 200 mV if the amplitude of the input signal is higher than  $1 V_{rms}$
  - Connect the signal with the highest frequency to input A and the other signal to input B
- Display will show the ratio of the signal frequencies at input A and B

### Ratio C/B PM 6624 and PM 6625

Simple ratio measurement on sine wave and other symmetrical waveforms.

- Set FUNCTION SELECTOR to  $10^4$  or  $10^6$
- Set INPUT A/INPUT C to INPUT C
- Pull TRIGGER LEVEL control
- Set SEP/COM to SEP
- Set AC/DC to AC
- Set 20 mV/200 mV to 200 mV if the

### Periode B

Einfache Periodenmessung an sinusförmigen und anderen symmetrischen Signalformen.

- Funktionswähler auf SINGLE oder AVG stellen.
- PERIOD B/TIME INT. A TO B auf PERIOD B stellen.
- Einsteller TRIGGER LEVEL ziehen.
- AC/DC auf AC stellen.
- 20 mV/200 mV auf 200 mV stellen, wenn das Eingangssignal größer ist als  $1 V_{eff}$ .
- Triggerung auf positiver Flanke wählen.
- Signal an Eingang B legen. Die Periodendauer ist dann auf der Anzeige in ms oder ns abzulesen.

### Zeitintervall A—B

Einfache Messungen des Zeitintervalls zwischen Impulsen von getrennten Quellen an Eingang A und Eingang B.

- Funktionswähler auf SINGLE oder AVG stellen.
- PERIOD B/TIME INT. A TO B auf TIME INT. A TO B stellen.
- 20 mV/200 mV auf 200 mV stellen, wenn das Eingangssignal größer ist als  $3 V_{s-s}$ .
- AC/DC auf DC stellen.
- SEP/COM auf SEP stellen.
- Triggerung auf positiver Flanke wählen.
- Potentiometer TRIGGER LEVEL auf einen passenden Triggerpegel einstellen, z.B. 50 % der Impulsamplitude.
- Impulse an Eingang A bzw. Eingang B legen. Das Zeitintervall ist dann auf der Anzeige in ms oder ns abzulesen.

### Verhältnis A/B

Einfache Verhältnismessung an sinusförmigen oder anderen symmetrischen Signalformen.

- Funktionswähler auf  $10^4$  oder  $10^6$  stellen.
  - Potentiometer TRIGGER LEVEL ziehen.
  - AC/DC auf AC stellen.
  - SEP/COM auf SEP stellen.
  - 20 mV/200 mV auf stellen, wenn das Eingangssignal größer ist als  $1 V_{eff}$ .
  - Signal mit der höheren Frequenz an Eingang A, das andere Signal an Eingang B legen.
- Das Verhältnis der Signalfrequenzen an Eingang A und B ist dann auf der Anzeige abzulesen.

### Verhältnis C/B an PM 6624 und PM 6625

Einfache Verhältnismessung an sinusförmigen oder anderen symmetrischen Signalformen.

- Connecter le signal d'entrée à l'entrée C
- L'affichage indiquera la fréquence en MHz ou en KHz

### Période B

Mesures de période simple sur ondes sinusoïdales et autres ondes symétriques

- Régler le sélecteur de fonctions sur SINGLE (simple) ou sur AVG (moyenne)
  - Régler PERIOD B/ TIME INT. A TO B sur PERIOD B
  - Tirer la commande TRIGGER LEVEL (niveau de déclenchement)
  - Mettre AC/DC sur AC
  - Régler 20 mV/200mV sur 200 mV si l'amplitude du signal d'entrée est supérieure à  $1 V_{eff}$
  - Sélectionner le déclenchement sur pente positive
  - Connecter le signal à l'entrée B
- L'affichage indique le temps de période en ms ou en ns

### Intervalle de temps A à B

Mesure simple de temps entre impulsions aux entrées A et B à partir de sources séparées

- Mettre le sélecteur de fonctions en position SINGLE ou AVG
  - Mettre PERIOD B/TIME INT. A TO B sur TIME INT. A TO B
  - Régler 20 mV/200 mV sur 200 mV si l'amplitude du signal d'entrée est supérieure à  $3 V_{o-o}$
  - Mettre AC/DC sur DC
  - Mettre SEP/COM sur SEP
  - Sélectionner le déclenchement sur pente positive
  - Régler le potentiomètre TRIGGER LEVEL au niveau approprié, par ex 50 % de l'amplitude d'impulsion
  - Connecter les impulsions aux entrées A et B
- L'affichage indiquera l'intervalle de temps en ms ou en ns

### Rapport A/B

Mesure simple de rapport sur onde sinusoïdale ou autres ondes symétriques

- Mettre le sélecteur de fonctions sur  $10^4$  ou  $10^6$
  - Tirer la commande TRIGGER LEVEL
  - Mettre AC/DC sur AC
  - Mettre SEP/COM sur SEP
  - Mettre 20 mV/200 mV sur 200 mV si l'amplitude du signal d'entrée est supérieure à  $1 V_{eff}$
  - Connecter le signal à fréquence la plus haute à l'entrée A, et l'autre signal à l'entrée B
- L'affichage indiquera le rapport des fréquences de signaux aux entrées A et B

amplitude of the input signal is higher than  $1 V_{rms}$

— Connect the signal with the highest frequency to input C and the other to input B

Display will show the ratio of the signal frequencies at input C and B

### Count A Start/Stop and Gated by B

Simple Start/Stop and Gated by B measurement on sine wave and other symmetrical waveforms.

— Set FUNCTION SELECTOR to COUNT A

— Pull TRIGGER LEVEL control

— Set AC/DC to AC for channel A

— Set AC/DC to DC for channel B

— Set SEP/COM to SEP

— Set 20 mV/200 mV to 200 mV if the amplitude of the input signal is higher than  $1 V_{rms}$

— Select positive slope triggering

— Select Start/Stop by B (upper position) or Gated by B (lower position)

— Connect gating signal to input B and the other signal to input A

In Start/Stop operation the display will show the accumulated number of counts in the time interval between the Start/Stop signals, and in the Gated mode the accumulated number of counts during the positive and negative slopes of the Gating signal

### Hold off PM 6622

— Set FUNCTION SELECTOR to 0.1  $\mu s$  and rotate HOLD OFF control from fully CCW to fully CW position

— Read hold off time from 0.01 to 0.5 ms on the display with knob pushed and 0.5 ms to 100 ms with knob pulled

— Funktionswähler auf  $10^4$  oder  $10^6$  stellen.

— INPUT A/INPUT C auf INPUT C stellen.

— Potentiometer TRIGGER LEVEL ziehen.

— SEP/COM auf SEP stellen.

— AC/DC auf AC stellen.

— 20 mV/200 mV auf 200 mV stellen, wenn das Eingangssignal größer ist als  $1 V_{eff}$ .

— Signal mit der höheren Frequenz an Eingang C, das andere an Eingang B legen.

Das Verhältnis der Signalfrequenzen an Eingang C und B ist dann auf der Anzeige abzulesen.

### Zählung zwischen Start/Stop oder torgesteuert von B

Einfache Zählung (Summenbildung) an sinusförmigen oder anderen symmetrischen Signalformen.

— Funktionswähler auf COUNT A stellen.

— Einsteller TRIGGER LEVEL ziehen.

— AC/DC für Kanal A auf AC stellen.

— AC/DC für Kanal B auf DC stellen.

— SEP/COM auf SEP stellen.

— 20 mV/200 mV auf 200 mV stellen, wenn das Eingangssignal größer ist als  $1 V_{eff}$ .

— Triggerung auf positiver Flanke wählen.

Im Start/Stop-Betrieb erscheint auf der Anzeige die zwischen Start- und Stoppsignal summierte Zahl der Impulse. Bei Torsteuerung wird die Summe der Impulse während der positiven und der negativen Flanke des Torsignals gebildet.

### Triggervverzögerung PM 6622

— Funktionswähler auf 0,1  $\mu s$  stellen und Einsteller HOLD OFF vom Linksanschlag bis Rechtsanschlag drehen.

— Verzögerungszeiten von 0,01 bis 0,5 ms sind dann bei eingedrücktem Knopf abzulesen, Zeiten von 0,5 bis 100 ms bei gezogenem Knopf.

### Rapport C/B pour PM 6624 et PM 6625

Mesure de rapport simple sur onde sinusoïdale et autres ondes symétriques

— Mettre le sélecteur de fonctions sur  $10^4$  et  $10^6$

— Mettre INPUT A/INPUT C sur INPUT C

— Tirer la commande TRIGGER LEVEL

— Mettre SEP/COM sur SEP

— Mettre AC/DC sur AC

— Régler 20 mV/200 mV sur 200 mV si l'amplitude de signal d'entrée est supérieure à  $1 V_{eff}$

— Connecter le signal à fréquence la plus haute à l'entrée C et l'autre à l'entrée B

L'affichage indiquera le rapport des fréquences de signaux aux entrées C et B

### Comptage A Démarrage/arrêt et Déclenchement par B

Mesure simple arrêt/démarrage et déclenchement par B sur onde sinusoïdale et autres ondes symétriques

— Mettre le sélecteur de fonctions sur COUNT A

— Tirer la commande TRIGGER LEVEL

— Mettre AC/DC sur AC pour voie A

— Mettre AC/DC sur DC pour voie B

— Mettre SEP/COM sur SEP

— Mettre 20 mV/200 mV sur 200 mV si l'amplitude du signal d'entrée est supérieure à  $1 V_{eff}$

— Sélectionner le déclenchement sur pente positive

— Sélectionner arrêt/démarrage par B (position supérieure) ou déclenchement par B (position inférieure)

— Connecter le signal de déclenchement à l'entrée B et l'autre signal à l'entrée A

En mode démarrage/arrêt, l'affichage indique le nombre de comptages accumulés dans l'intervalle de temps entre les signaux démarrage/arrêt; et en mode de déclenchement, l'affichage indique le nombre de comptages accumulés pendant les pentes positives et négatives du signal de déclenchement (gating)

### Retard de déclenchement du PM 6622

— Mettre le sélecteur de fonctions sur 0.1  $\mu s$  et tourner la commande HOLD OFF de position extrême gauche en position extrême droite.

— Lire le temps de retard de 0.01 à 0.5 ms sur l'affichage avec le bouton en position enfoncée, et de 0.5 ms à 100 ms avec le bouton en position tirée.

## Performance Check

## Self check of measuring modes

## Preliminary setting of the controls

- Release all push-buttons
- Minimum display time
- Pull the trigger level controls
- Hold off to position off
- Internal oscillator on
- Self check on

## Frequency A

- Do the preliminary setting of the controls
- Perform the test below

Function Selector	Gate lamp	Unit lamp	Display ( $\pm 1$ digit)
Frequency A 100 Hz	blinking	MHz	00010.0000
Frequency A 10 Hz	blinking	MHz	0010.00000
Frequency A 1 Hz	blinking	kHz	010000.000
Frequency A 0.1 Hz	blinking	kHz	10000.0000

## Frequency C PM 6624

- Do the preliminary setting of the controls
- Perform the test below

Function Selector	Gate lamp	Unit lamp	Display ( $\pm 1$ digit)
Frequency C 100 Hz	blinking	MHz	00080.0000
Frequency C 10 Hz	blinking	MHz	0080.00000
Frequency C 1 Hz	blinking	kHz	080000.000
Frequency C 0.1 Hz	blinking (slow rate)	kHz	80000.0000

## Frequency C PM 6625

- Do the preliminary setting of the controls
- Perform the test below

Function Selector	Gate lamp	Unit lamp	Display ( $\pm 1$ digit)
Frequency C 100 Hz	blinking	MHz	00160.0000
Frequency C 10 Hz	blinking	MHz	0160.00000
Frequency C 1 Hz	blinking	kHz	160000.000
Frequency C 0.1 Hz	blinking (slow rate)	kHz	60000.0000

## Single Period B

- Do the preliminary setting of the controls
- Perform the test below

Function Selector	Gate lamp	Unit lamp	Display ( $\pm 1$ digit)
Period B 0.1 ms	blinking	ms	00000000.0
Period B 0.1 $\mu$ s	blinking	ms	00000.0001

## Period Average B

- Do the preliminary setting of the controls
- Perform the test below

Function Selector	Gate lamp	Unit lamp	Display ( $\pm 1$ digit)
Period B $10^2$	blinking	ns	000000100.
Period B $10^4$	blinking	ns	0000100.00
Period B $10^6$	blinking	ns	00100.0000

## Single Time Interval A to B

- Do the preliminary setting of the controls
- Perform the test below

Function Selector	Gate lamp	Unit lamp	Display ( $\pm 1$ digit)
Time Int. 0.1 ms	blinking	ms	00000000.0
Time Int. 0.1 $\mu$ s	blinking	ms	00000.0001

## Time Interval Average A to B

- Do the preliminary setting of the controls
- Perform the test below

Function Selector	Gate lamp	Unit lamp	Display ( $\pm 1$ digit)
Time Int. $10^2$	blinking	ns	000000000 or any value
Time Int. $10^4$	blinking	ns	0000000.00 or any value
Time Int. $10^6$	blinking	ns	00000.0000 or any value

## Ratio A/B

- Do the preliminary setting of the controls
- Perform the test below

Function Selector	Gate lamp	Unit lamp	Display ( $\pm 1$ digit)
Ratio A/B $10^6$	blinking	off	001.000000
Ratio A/B $10^4$	blinking	off	0000.10000

## Ratio C/B PM 6624

- Do the preliminary setting of the controls
- Perform the test below

Function Selector	Gate lamp	Unit lamp	Display ( $\pm 1$ digit)
Ratio C/B $10^6$	blinking	off	008.000000
Ratio C/B $10^4$	blinking	off	00008.0000

## Performance Check



### Ratio C/B PM 6625

- Do the preliminary setting of the controls
- Perform the test below

Function Selector	Gate lamp	Unit lamp	Display ( $\pm 1$ digit)
Ratio C/B $10^6$	blinking	off	016.000000
Ratio C/B $10^4$	blinking	off	00016.0000

### Count A

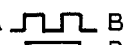
- Do the preliminary setting of the controls
- Perform the test below

Function Selector	Gate lamp	Unit lamp	Display ( $\pm 1$ digit)
Count A  B	blinking	off	000000002
Count A  B	blinking	off	000000001 or 000000000

### Functional test of sockets and controls

#### Preliminary setting of the controls

- Release all push-buttons
- Minimum display time
- Pull the trigger level controls
- Hold off to position off
- Internal oscillator on

#### Display time

- Do the preliminary setting of the controls
- Set the function selectors to Frequency A 1 Hz
- Note that flashing frequency of the Gate lamp decreases from one flash every second to one flash every five seconds when the Display Time potentiometer is turned from the min. time position to max. time position.

#### Memory

- Do the preliminary setting of the controls
- Set the Function Selectors to Frequency A 1 Hz
- Set Display Time to max. position
- Observe the display and check that the counter is counting during 1 second and displays 10 000 kHz during 4 seconds when Memory push-button is depressed.

#### Reset

- Do the preliminary setting of the controls
- Set the Function Selectors to Frequency A 0.1 Hz
- Depress Memory push-button
- Check that counter displays zero as long as the Reset push-button is depressed.

### Display digits

- This test requires a 80 MHz pulse generator
- Do the preliminary setting of the controls
- Set the function selectors to Count A Gated by B
- Depress Memory push-button
- Set Trigger Level B to +2.5 V
- Connect Sync Out from the pulse generator to Input A
- Set the pulse generator to a repetition time of 1 second
- Check that digit N:o 9 is displaying all numbers from 0 to 9 when the Trigger Level B control is set from the +2.5 V position to the -2.5 V position
- Depress Reset push-button
- Set Trigger Level B control to the +2.5 V position
- Vary the Repetition Time of the pulse generator and check the remaining 8 digits as shown in table below

Digit N:o	1 (MSD)	2	3	4
Rep. time	12 ns	100 ns	1 $\mu$ s	10 $\mu$ s

Digit N:o	5	6	7	8	9 (LSD)
Rep. time	100 $\mu$ s	1 ms	10 ms	100 ms	1 s

### Trigger Level A and B

This test requires a voltmeter

- Do the preliminary setting of the controls
- Perform the test below

Trigger Level A setting	Measured voltage Monitor socket A	Trigger lamp A
-2.5 V position	-2.3 V ... -2.7 V	off
+2.5 V position	+2.3 V ... +2.7 V	on

- Repeat the test for Trigger Level B

### Hold off PM 6622

- Do the preliminary setting of the controls
- Set the Function Selectors to Period B 0.1  $\mu$ s
- Perform the test below

Hold off setting	Displayed value
10 $\mu$ s	less than 10 $\mu$ s
500 $\mu$ s	more than 500 $\mu$ s
0.5 ms	less than 500 $\mu$ s
100 ms	more than 100 ms

## Performance Check

### Positive and negative slopes A and B

This test requires a low frequency oscilloscope, a pulse generator and a BNC T-piece.

- Do the preliminary setting of the controls
- Set Function Selectors to Time Interval 0.1  $\mu$ s
- Depress AC/DC push-buttons
- Set Trigger Levels A and B to approximately 0.5 V

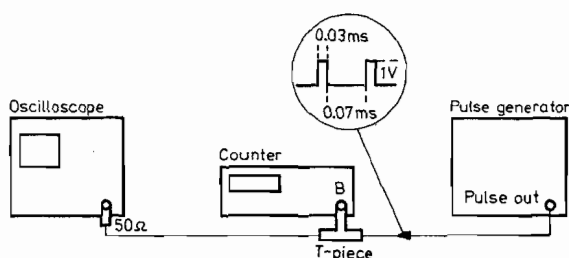

- Set the output signal from the pulse generator to an amplitude of 1 V, a repetition time of 0.1 ms and a duty factor of 0.3
- Perform the test below

Slope setting channel A	Slope setting channel B	Displayed value
		00000.1000 ms
		00000.0300 ms
		00000.1000 ms
		00000.0700 ms

### Sine wave sensitivity and ac/dc coupling Input A

This test requires a sine wave generator with a frequency range of 10 Hz to 80 MHz, a high frequency oscilloscope and a T-piece.

- Do the preliminary setting of the controls
- Set the Function Selectors to Frequency A 1 Hz

#### Test set up for 80 MHz measurement

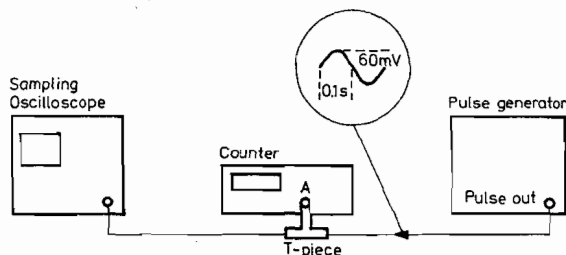

- Set the output signal from the sine wave generator to an amplitude of 60 mV<sub>p-p</sub> and a frequency of 10 Hz
- Perform the test below

Sine wave frequency	Coupling ac or dc	Displayed value
10 Hz	ac	000000.000 kHz
10 Hz	dc	000000.010 kHz
100 Hz	dc	000000.100 kHz
100 kHz	dc	000100.000 kHz
80 MHz	dc	080000.000 kHz

### Pulse sensitivity Input B

This test requires a 3 MHz pulse generator, a low frequency oscilloscope and a T-piece.

- Do the preliminary setting of the controls
- Set Input B to dc coupling and the Function Selectors to Period B 10<sup>2</sup>

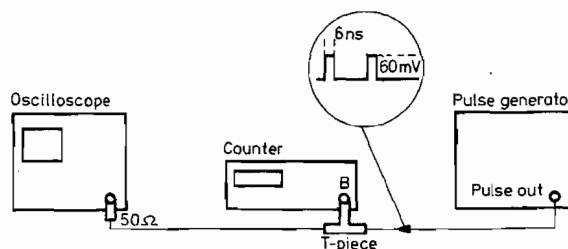

- Set the pulse generator:

Amplitude: 60 mV  
 Pulse width: 6 ns  
 Frequency: 100 Hz  
 Pulse mode: normal  
 Polarity: positive

- Adjust Trigger Level control B until counter displays correct display read out according to the table below

Pulse generator frequency	Function selector	Displayed value
100 Hz	Period B 10 <sup>2</sup>	001000000 ns
100 kHz	Period B 10 <sup>4</sup>	0010000.00 ns
3 MHz	Period B 10 <sup>6</sup>	00333.0000 ns

### Sine wave sensitivity Input C PM 6624

This test requires a sine wave generator with a frequency range of 50 MHz to 520 MHz, a high frequency oscilloscope and a T-piece.

- Do the preliminary setting of the controls
- Set the Function Selectors to Frequency C 10 Hz

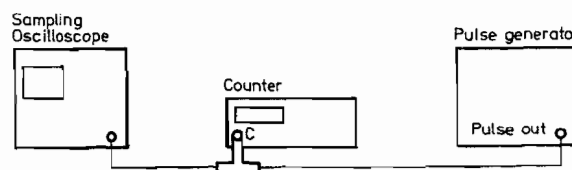

- Perform the test below

Sine wave frequency	Sine wave amplitude	Displayed value
50 MHz	30 mV <sub>p-p</sub>	0050.00000 MHz
200 MHz	30 mV <sub>p-p</sub>	0200.00000 MHz
520 MHz	30 mV <sub>p-p</sub>	0520.00000 MHz

**Performance Check**

**Sine wave sensitivity Input C PM 6625**

This test requires a sine wave source with a frequency range of 50 MHz to 1 000 MHz, a high frequency oscilloscope and a T-piece.

- Do the preliminary setting of the controls
- Set the Function Selectors to Frequency C 10 Hz

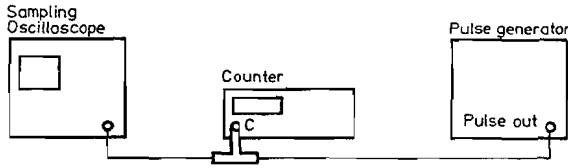

— Perform the test below

Sine wave frequency	Sine wave amplitude	Displayed value
50 MHz	30 mV <sub>p-p</sub>	0050.00000 MHz
400 MHz	30 mV <sub>p-p</sub>	0400.00000 MHz
960 MHz	30 mV <sub>p-p</sub>	0960.00000 MHz
1 000 MHz	40 mV <sub>p-p</sub>	1000.00000 MHz

**Gate open PM 6622**

This test requires a low frequency oscilloscope, a pulse generator and a T-piece.

- Do the preliminary setting of the controls
- Set the Function Selectors to Time Interval A to B 0.1 ms, the Hold Off time to 100 ms and depress SEP/COM push-button
- Set the amplitude of the output signal from the pulse generator to 1 V, the repetition time to 0.1 ms and the duty factor to 0.3

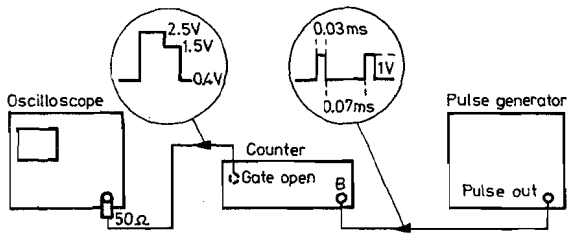

— Check that the oscilloscope displays the wave form below

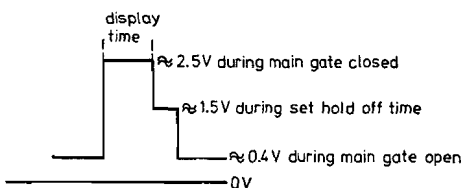

**Gate open PM 6624 and PM 6625**

This test requires a low frequency oscilloscope, a pulse generator and a BNC T-piece

- Do the preliminary setting of the controls
- Set Function Selectors to Time Interval A to B 0.1 ms and depress SEP/COM push-button
- Set the output signal from the pulse generator to an amplitude of 1 V, a repetition time of 0.1 ms and a duty factor of 0.3

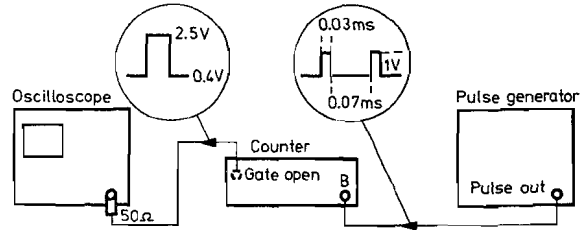

— Check that the oscilloscope displays the wave form below

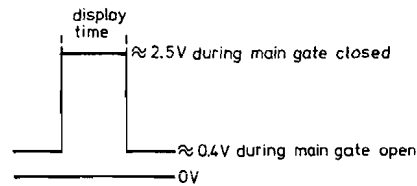

**External reset**

This test requires a pulse generator with dc offset

- Do the preliminary setting of the controls
- Set the function selectors to Frequency A 10 Hz
- Set the Function Selectors to Frequency A 10 Hz
- Pull Display Time switch
- Depress Check push-button
- Set the pulse generator to single shot and inverted pulse mode
- Set the pulse to a width of 100 ns, an amplitude of 2 V and +0.4 V dc offset.

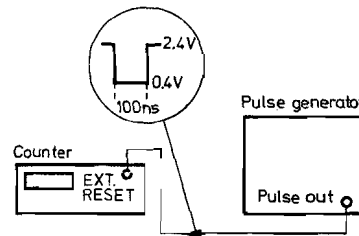

— Check that the Gate lamp is blinking and that digit N:o 1 (MSD) displays zero each time push-button Single Shot is depressed

**10 MHz Out**

This test requires a low frequency oscilloscope and a 500 Ω probe.

- Do the preliminary setting of the controls
- Connect the oscilloscope to socket D and check that the oscilloscope displays a wave form with an amplitude of 1.8 V<sub>p-p</sub> and a frequency of 10 MHz.

## Oscillator PM 9677

## Oscillator frequency check

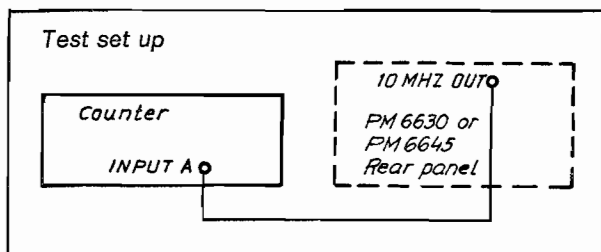

— This check requires a frequency standard having an accuracy of  $1 \times 10^{-6}$ . The oven enclosed oscillators Philips PM 9680, PM 9681 and PM 9690 meet this requirement. The check should preferably be made at an ambient temperature of  $+25^\circ \text{C}$ .

— Set the controls of the counter:

FUNCTION SELECTOR: FREQUENCY A 1 Hz

TRIGGER LEVEL A: pulled

— Check that display shows 10000.000 kHz  $\pm 10$  Hz.

## Oscillator frequency adjustment

This adjustment requires a reference oscillator having an accuracy of  $\leq 1 \times 10^{-6}$ .

The oven enclosed PHILIPS oscillators PM 9680\*, PM 9681\* and PM 9690\* meet this requirement.

The adjustment should preferably be made at an ambient temperature of  $+25^\circ \text{C}$ .

— Remove the bottom cover of the counter.

— Connect the reference signal available at socket 10 MHz OUT of the external counter to INPUT A of the counter to be adjusted.

— Set the controls of the counter to be adjusted:

FUNCTION SELECTOR: FREQUENCY A 1 Hz

TRIGGER LEVEL A: pulled

— Adjust trimming capacitor C 1 to 10000.000 kHz plus or minus 10 Hz.

## Component layout

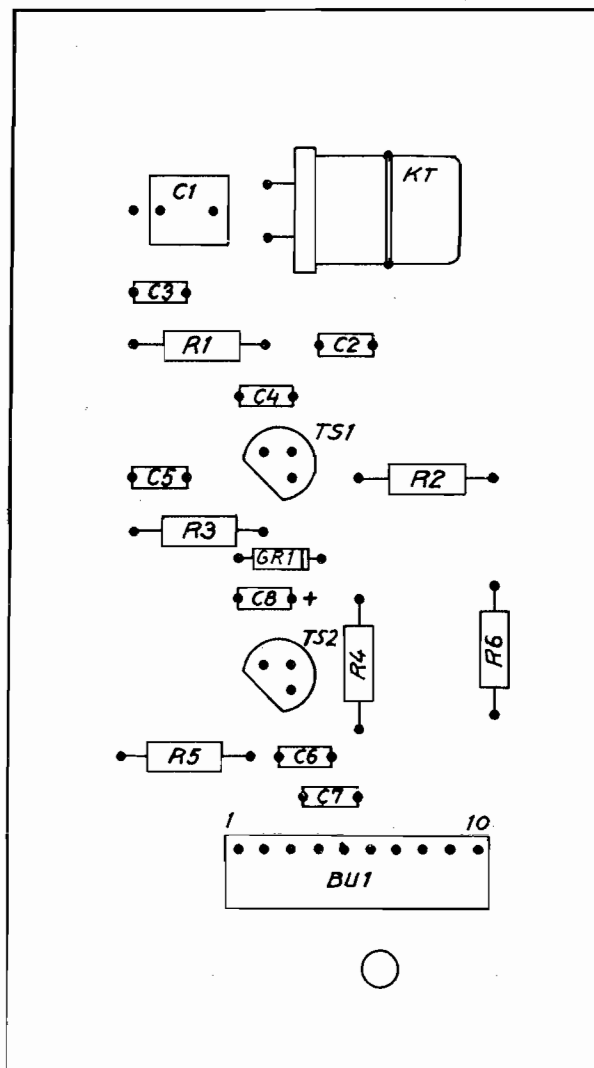

## Circuit diagram

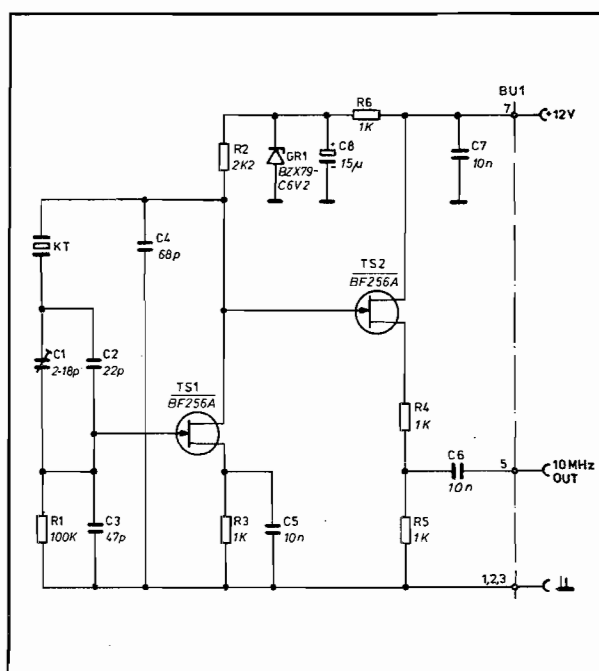

## Spare parts

Ordering no	$\Omega/F$	%	V/W	Item
4822 110 63161	100k	5	CR25	R1
4822 110 63116	2,2k	5	CR25	R2
4822 110 63107	1k	5	CR25	R3
4822 110 63107	1k	5	CR25	R4
4822 110 63107	1k	5	CR25	R5
4822 110 63107	1k	5	CR25	R6
5322 125 54029	2—18p		300	C1
4822 122 31063	22p	2	100	C2
4822 122 31072	47p	2	100	C3
4822 122 31076	68p	2	100	C4
5322 122 34041	10n	—20 +50	100	C5
5322 122 34041	10n	—20 +50	100	C6
5322 122 34041	10n	—20 +50	100	C7
5322 124 14036	15 $\mu$	—10 +50	16	C8

Ordering no	Description	Item
5322 130 44418	BF 256 A	TS1
5322 130 44418	BF 256 A	TS2
5322 130 30766	BZX79—C6V2	GR1
5322 242 74036	Crystal 10MHz	
5322 267 64031	Connector	BU1

## Oscillator PM 9678

### Oscillator frequency check

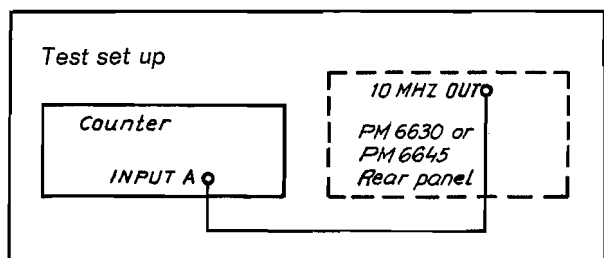

— This check requires a frequency standard having an accuracy of  $1 \times 10^{-7}$ .  
 The oven enclosed oscillators Philips PM 9680, PM 9681 and PM 9690 meet this requirement.  
 The check should preferably be made at an ambient temperature of  $+25^\circ \text{C}$ .

— Set the controls of the counter:

FUNCTION SELECTOR: FREQUENCY A 0.1 Hz  
 TRIGGER LEVEL A: pulled

— Check that the display shows 10000.0000 kHz  $\pm 1$  Hz.

### Oscillator frequency adjustment

— This adjustment requires a reference oscillator having an accuracy of  $\leq 1 \times 10^{-7}$ .  
 The oven enclosed PHILIPS oscillator PM 9680\*, PM 9681\* and PM 9690\* meet this requirement.  
 The adjustment should preferably be made at an ambient temperature of  $+25^\circ \text{C}$ .

— Remove the bottom cover of the counter.

— Connect the reference signal available at socket 10 MHz OUT of the external counter to INPUT A of the counter to be adjusted.

— Set the controls of the counter to be adjusted:

FUNCTION SELECTOR: FREQUENCY A 1 Hz  
 TRIGGER LEVEL A: pulled

— Adjust trimming capacitor C 1 to 10000.000 kHz plus or minus 1 Hz.

— Set FUNCTION SELECTION to position 0.1 Hz and check that display read out is the same as before. If not, adjust C 1 slightly to correct frequency.

### Spare parts

Ordering number	Description	Item
4822 110 63098	470 $\Omega$ 5 %	R 1
5322 125 50057	5—65 P 100 V	C 1
5322 124 14036	15 M —10+50 % 16 V	C 2
5322 267 64031	Connector	BU 1
5322 216 94047	Crystal 10 MHz	

### Component layout

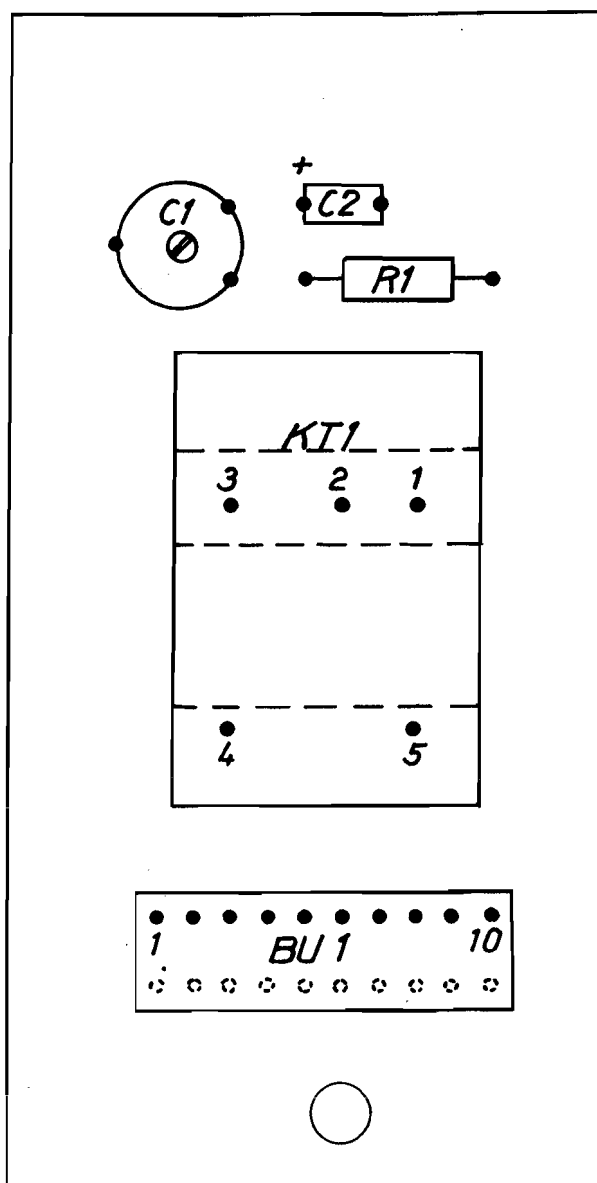

### Circuit diagram

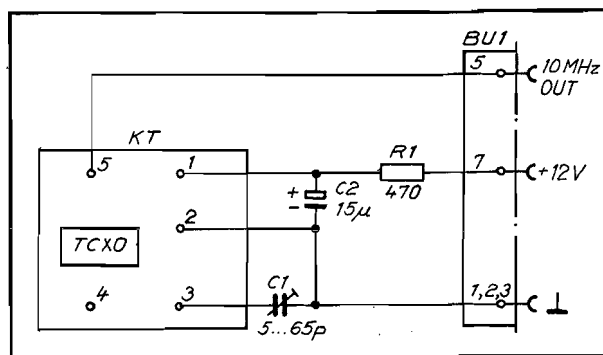



## Oven Oscillators PM 9679B, PM 9690 and PM 9691

## Oscillator frequency adjustment

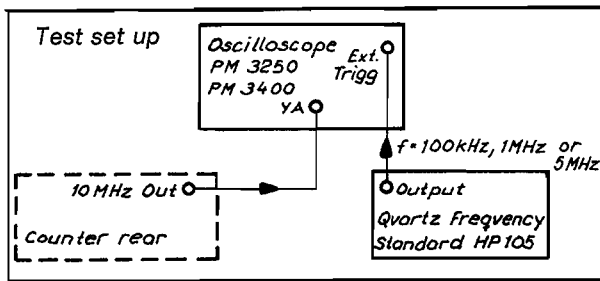

This adjustment requires a frequency standard having an accuracy of  $3 \times 10^{-8}$  for PM 9679B,  $10^{-9}$  for PM 9690 and better than  $5 \times 10^{-10}$  for PM 9691. Hewlett-Packard quartz frequency standard HP 105\* meets this requirement.

The adjustment should preferably be made at an ambient temperature of  $25^\circ\text{C}$  and the oscillator must have been operating continuously 72 h before any adjustment is made.

- Remove the bottom cover of the counter
- Do the test set up
- Set the oscilloscope to 100 ns/div and adjust the oscillator's fine trimmer until the waveform on the oscilloscope moves with a velocity of maximum 1 div/10 s (0.1 Hz).

If the adjustment range is too narrow a coarse trimmer is available under the oscillator's text plate.

\* To be adjusted against a frequency standard such as Draitwich or HBG.

## Repair of the oscillator

— Repair of this oscillator may not be carried out by the local service organisations. In case of breakdown the complete sealed oscillator box has to be sent to the factory for repair.

Factory address:

PHILIPS ELEKTRONIKINDUSTRIER AB  
INDUSTRIAL OPERATIONS  
FAK  
S-175 20 JÄRFÄLLA  
SWEDEN

## Pin configuration

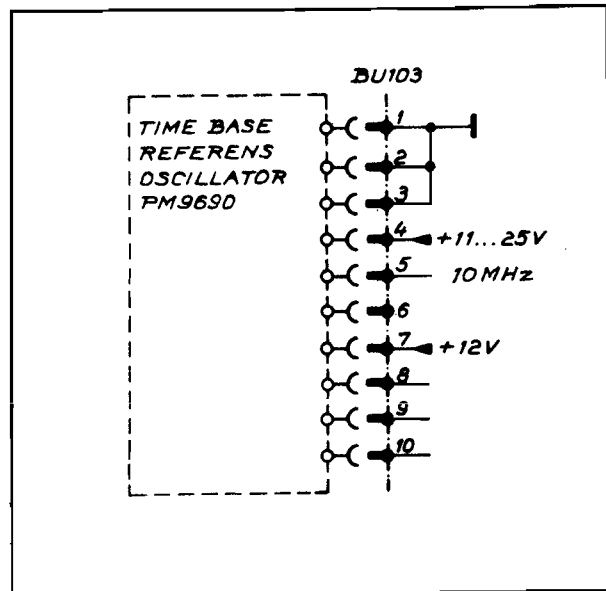

## Power supply

### General

The power supply operates from 115 V AC or 230 V AC 50 to 400 Hz or from the internal battery PM 9673 or from an external battery with an output voltage of 12 to 28 V. It provides five stabilised and overload-protected voltages of +120 V, +12 V, +5 V, -5 V and -50 V.

The power supply may be divided into the *power input circuit* mainly consisting of the mains transformer T 101 and rectifier GR 167, the *over-voltage protection circuit* mainly consisting of thyristor TS 150, TS 151 and zener diode GR 160, the *voltage regulation circuit* mainly consisting of voltage regulator IC 150, thyristor TS 154, the *DC-to-DC converter* mainly consisting of primary side of transformer T 102, driver TS 152 and switch TS 153.

### Power input circuit

When the power supply operates from the *mains*, the 115 V AC or 230 V AC is transformed to 20 V AC by transformer T 101, rectified in the diode-bridge GR 167, filtered by C 152 and C 161 and fed to the power supply circuits via switch SK 121 and SK 102.

When the power supply operates from an *external battery* the current to the power supply circuits is fed from BU 21 at the rear panel via protecting diode GR 164 and switches SK 121 and SK 102.

When the internal battery is used the current is fed from pin 8 of BU 105 via SK 121 and SK 102 to the power supply circuits.

### D.c. to d.c. converter

The DC to DC converter is basically a blocking oscillator consisting mainly of switch transistor TS 153 and terminals 4—9 of the transformer T 102. When switch SK 102 is set to position ON, the DC voltage from the *power input circuit* is fed to the transistor TS 155 which works as a constant current source of approximately 1 mA ( $I_1$ ).

The current  $I_1$  will cause switch transistor TS 153 to start conducting and the linearly increasing current  $I_2$  to flow.

This current  $I_2$  will cause a voltage across terminals 3—8 of the transformer and the current  $I_3$  will start to flow.

This will cause drive transistor TS 152 to saturate switch transistor TS 153. When the transistor no longer can saturate, current  $I_3$  will stop to increase and the induced voltage at terminal 3 of transformer T 102 will disappear.

This will cause TS 153 to switch off and the collector voltage to rise to the same level as the supply voltage. At this moment the magnetic flux will discharge through the secondary windings of T 102 and diodes GR 155—159.

### Current paths in d.c. to d.c. converter

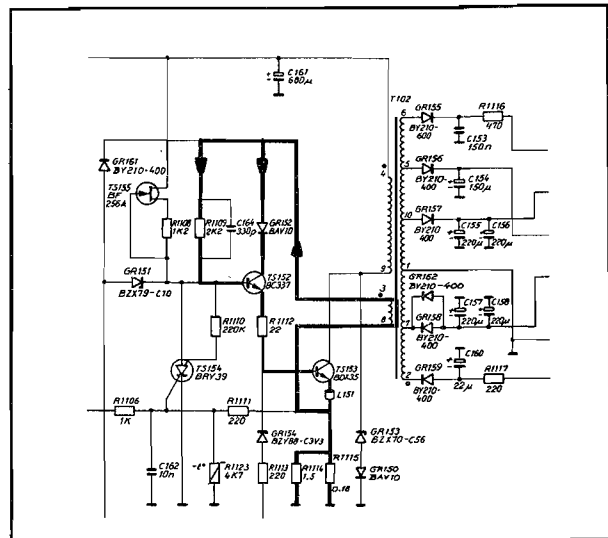
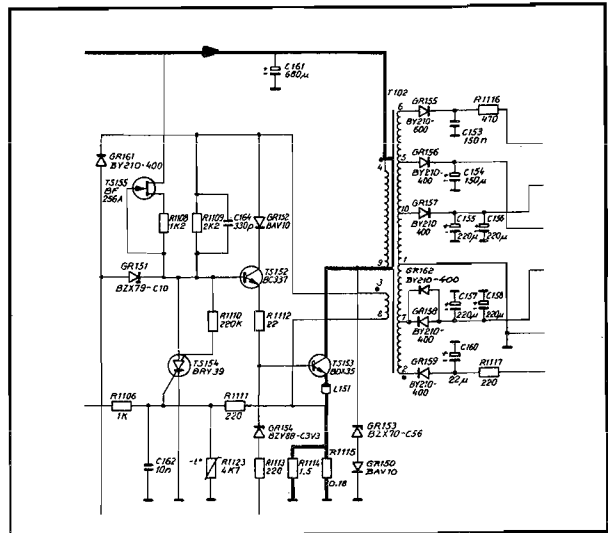
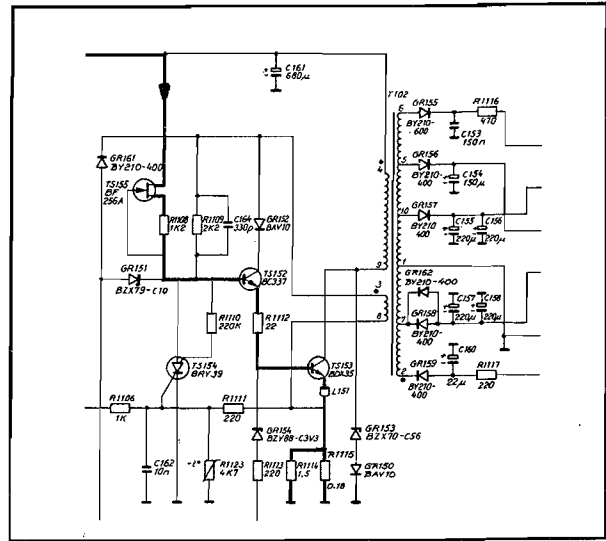

### Over voltage protection

The over-voltage protection circuit consists mainly of thyristors TS 150, TS 151 and zener diode GR 160.

The anode of GR 160 is connected to the +5 V output from the power supply. If this voltage increases to 5.6 V... 5.8 V, the zener diode GR 160 will start to conduct and a current will flow through resistor R 1121. The voltage drop across R 1121 is fed to the gate of thyristor TS 151 via resistor R 1120. The anode is connected to the +5 V output voltage via resistor R 1118.

The thyristor will switch on and a voltage drop arises across resistor R 1122. This voltage is fed to the gate of thyristor TS 150, whose anode is connected to the d.c. input voltage. The thyristor will switch on and blow fuse VL 150, or, if the counter is operating in the internal battery mode, fuse VL 1 in the battery unit PM 9673. The capacitor across the gate and cathode of thyristor TS 151 prevents transients from the mains to blow fuse VL 150 accidentally.

### Output voltage regulation circuit

The output voltage regulation circuit consists mainly of voltage regulator IC 150 and thyristor TS 154.

The purpose of the thyristor TS 154 is to switch off the drive transistor TS 152 in order to regulate the output voltage. The switching moment of thyristor TS 154 is determined by a voltage at the gate of the thyristor which is the sum of a DC regulation voltage from terminal 10 of IC 150 and a sawtooth voltage caused by the emitter current of TS 153 through resistor R 1114//R 1115.

The voltage regulator IC 150 is fed at terminal 12 with the supply voltage and at terminal 7 with a negative voltage, via GR 161, from winding 3—8 of transformer T 102.

IC 150 contains a differential amplifier with inputs at terminals 4 and 5.

The input at terminal 5 is grounded via R 1104 and the input at terminal 4 is connected to a voltage divider that consists of the reference output at terminal 6 and the negative voltage from winding 3—8 of transformer T 102 at terminal 7.

The differential amplifier is in balance when the voltage at terminal 7 is -5 V. When the supply voltage across windings 4—9 of transformer T 102 increases, the voltage at the differential amplifier at terminal 7 of IC 150 will go more negative, the DC regulation voltage at terminal 10 of IC 150 will go positive and turn on thyristor TS 154. This will connect the base of driver transistor to the ground and cause switch transistor TS 153 to switch off. The stored magnetic flux will then discharge in the secondary windings of T 102 and diodes GR 155—GR 159.

### Replacing parts in the power supply

When replacing parts in the power supply, in particular IC 150, always check the +5,0 V supply.

Proceed as follows:

— Connect a voltmeter to BU 107 pin +5.2 V and check that the voltage is 4.8—5.2 V.

If the measured voltage does not reach 4.8—5.2 V unsolder R 1103 and select a resistor value that gives the desired voltage. The value of this resistor may be 1 k $\Omega$  to 33 k $\Omega$ . Typical value is 8 k $\Omega$ .

— Check the d.c. voltages.

### D.C. voltages

— Connect the voltmeter to jumper connector BU 104 and check the d.c. voltages according to table below.

Test point	Measured voltage
+120	115... 130 V
+5.2	4.8... 5.2 V
+12	11.5... 13 V
-5.2	-5... -5.4 V
-50	-50... -60 V

### Dummy load

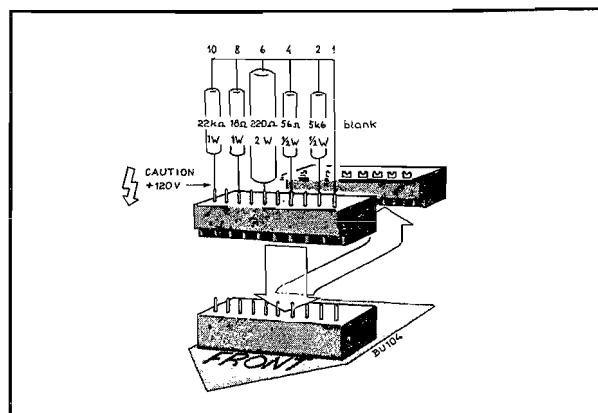

A fault in the power supply can be isolated easier if the counter circuits are disconnected by removing 10-pins connector BU 107. However, to simulate the load, a dummy load has to be fitted as shown in the figure. The dummy load can be assembled of the following components:

1 female connector 10 pins	5322 267 54102
1 carbon resistor 22 $\Omega$ , 1 W	4822 110 23143
1 carbon resistor 220 $\Omega$ , 1 W	4822 110 23089
1 carbon resistor, 18 $\Omega$ , 2 W	4822 110 10061
1 carbon resistor, 56 $\Omega$ , 0.5 W	4822 110 53074
1 carbon resistor, 5.6 k $\Omega$ , 0.5 W	4822 110 53127

**CAUTION:** + 120 V at pin 10 of the connector!

## Power Supply

### Troubleshooting the power supply

**Crowbar circuit.** The purpose of this circuit is to blow fuse VL 150 when the +5 V voltage becomes  $\approx +6$  V. If the fuse blows when the counter is switched on or off check TS 150. A simple way to check the performance of this circuit is to connect a dc source set to 1 A and 15 V to the external battery sockets at the rear panel of the counter and remove printed board BU 107. If the current limit lamp then turns on, indicating that TS 150 is conducting, the crowbar circuit is working properly.

**Voltage regulator.** The purpose of this circuits is to regulate the d.c. output levels by turning on TS 154 and stop the oscillating.

If the blocking oscillator does not oscillate check the voltage regulator by removing TS 154, if the blocking oscillator then starts to oscillate the fault may be caused by the voltage regulator.

**D.c. to d.c. converter.** This circuit is basically a blocking oscillator which is started by TS 155 and switched off by TS 154. If it is not oscillating check the voltage regulator and the base voltages at TS 152 ( $\approx 0.7$  V) and TS 153 ( $\approx 1.4$  V).

**Switch off transistor TS 154.** The purpose of this transistor is to switch off the blocking oscillator when the sum of the sawtooth voltage from the emitter of TS 153 and the dc voltage from terminal 10 of IC 150 becomes  $\approx 0.5$  V and turns on TS 154.

**Current generator TS 155.** The purpose of this transistor is to start the blocking oscillator by a bias current of  $\approx 1$  mA through base/emitter of TS 152 and TS 153. A voltage drop of  $\approx 1$  V across R1108 indicates that this circuit works properly.

### Component layout power supply

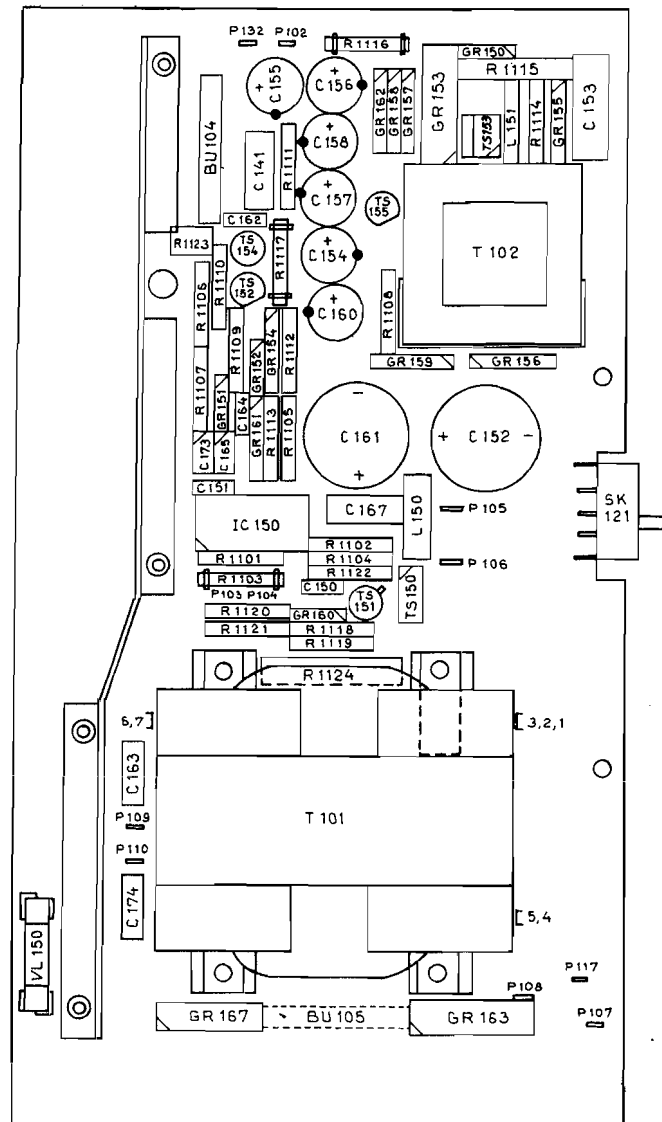

## Input amplifiers

## General

The input amplifiers are identically, input B is, however, functionally limited to 10 MHz. In common mode the input circuits of amplifier A are disconnected and the signal is fed from input B via the separate/ common switch to amplifier A.

The signal is analogue from the input socket to amplifier IC 101 and when measuring these circuits the oscilloscope should be earthed via the earth-pin at C 102 or C 112. From IC 101 to C 103 the signal has ECL levels. The output from TS 103:C and TS 104:C is a TTL signal. When measuring the ECL and TTL signals the oscilloscope should be earthed via the earth-pin at IC 102:1.

## Adjustment

## D.C. balance amplifier A

— Disconnect all input signals, release all push-buttons and set the controls of the counter:

Start/Stop                    upper position  
Trigg. level pot.            pulled

— Connect the voltmeter between IC 101:6 and ground and adjust R1104 until voltmeter shows 0 V  $\pm 2$  mV.

## D.C. balance amplifier B

— Disconnect all input signals, release all push-buttons and set the controls of the counter:

Start/Stop                    upper position  
Trigg. level pot.            pulled.

— Connect the voltmeter between IC 101:12 and ground and adjust R1104 until voltmeter shows 0 V  $\pm 2$  mV.

## Frequency compensation amplifier A

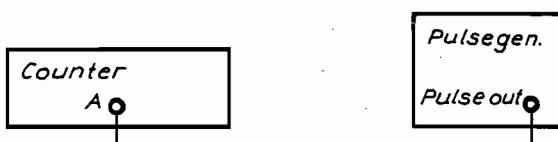

— Set the controls of the counter:

Attenuator                    200 mV position

— Set the controls of the pulse generator:

Frequency                    10 kHz  
Amplitude                    1 V  
Duty factor                    0.5

— Connect the oscilloscope via a well adjusted 10 M $\Omega$ /11 pF probe to terminal 6 of IC 101 and adjust C 102 to minimum distortion of the displayed waveform.

## Frequency compensation amplifier B

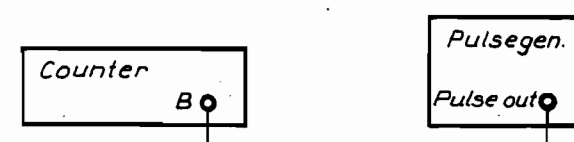

— Set the controls of the counter:

Attenuator                    200 mV position

— Set the controls of the pulse generator:

Frequency                    10 kHz  
Amplitude                    1 V  
Duty factor                    0.5

— Connect the oscilloscope via a well adjusted 10 M $\Omega$ /11 pF probe to terminal 12 of IC 101 and adjust C 112 to minimum distortion of the displayed waveform.

## Functional check

## Preliminary setting of the controls

- All push-buttons in released position.
- Display time potentiometer in power on position and minimum display time.
- Trigger level potentiometers in pulled position.
- Hold off in position off.
- Internal/external slide switch in position internal.

## Control circuits for prescaler and check modes

Truth table for channel A

	Check mode	Prescaler mode
SK 120		
pin 1	Floating	Ground
pin 3	Ground	
pin 4	High TTL	Ground
pin 6	Ground	
IC 101		
pin 1	Floating	Ground
pin 2	Low ECL	Don't care
pin 3	Low ECL	Don't care
IC 152		
pin 1	High TTL	Ground
pin 2	10 MHz	10 MHz
pin 3	10 MHz	High TTL
SK 108		
pin 2	High ECL	High ECL
pin 5	10 MHz ECL swing	High ECL
IC 103		
pin 5	Low ECL	Prescaler signal, ECL swing
pin 6	10 MHz ECL swing	Low ECL
IC 155:13	Low TTL	High TTL

## Amplifier and Schmitt-trigger IC 101

IC 101 is an amplifier and Schmitt trigger with analogue input and ECL output.

## Pin configuration IC 101

Enable	1	16	Ground
Out A	2	15	Out B
Out A	3	14	Out B
Clear A (−0.7 V)	4	13	Clear B (−0.7 V)
In −A	5	12	In +B
In +A	6	11	In −B
+5.0 V	7	10	+5.0 V
−5.2 V	8	9	Not connected

## Input amplifiers

### Tri state trigger indicator

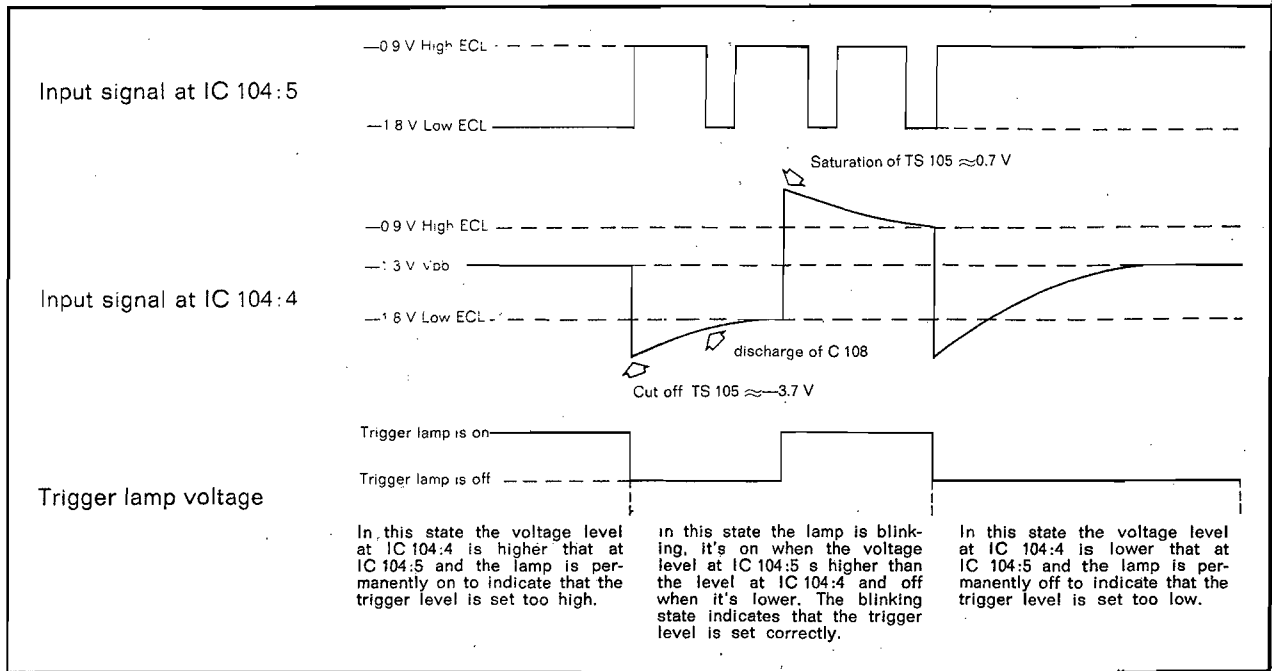

### Truth table IC 101

Ampl. A Pin 5 and 6	Ampl. B Pin 11 and 12	Ampl. A and B Pin 2 and 14	Ampl. A and B Pin 3 and 15	Enable Pin 1
6 > 5		H	H	Gnd
6 < 5		L	H	Gnd
	12 > 11	H	L	Gnd
	12 < 11	L	H	Gnd
Don't care	Don't care	—2.2 V	2...2.2 V	

H = -0.8 V    L = -1.8 V

### ECL/TTL converter

The input signal to IC 103 from the gate circuits has ECL levels. The A1 and A2 signals has TTL levels. The emitter signals of TS 103 and TS 104 has a voltage swing of approximately -0.8 V to -1.3 V.

### Prescaler level detector

The prescaler level detector will feed the signal from the prescaler unit at IC 104:10 to the ECL/TTL converter when voltage level at IC 104:9 is V<sub>bb</sub> (-1.3 V). When the prescaler unit is not used the voltage level at IC 104:9 is low ECL.

### Trigger level controls

- Do the preliminary setting of the counter.
- Depress trigger level controls and set them to fully CCW position.
- Check that the voltage at the monitor sockets are  $-2.7 \pm 0.2$  V and that the trigger indicator lamps are off.
- Set the trigger level controls to CW position.
- Check that the voltage at the monitor sockets are  $+2.7 \pm 0.2$  V and that the trigger indicator lamps are on.

### Slope controls

- Do the preliminary setting of the controls.
- Set the function selector to time interval A to B 0.1 ns and set the separate/common selector to common position.
- Connect a pulse generator to input B and set repetition time to 100 ms, duration to 30 ms and the amplitude to 1 V.
- Set the slope controls and check the display read-out according to table below.

Slope setting A and B	Display read-out	Unit
pos.    neg.	00000030.0	ms
pos.    pos.	00000100.0	ms
neg.    pos.	00000070.0	ms
neg.    neg.	00000100.0	ms

### ac/dc coupling

- Do the preliminary setting of the controls.
- Connect a square wave pulse with a frequency of 1 MHz, an amplitude of + 2 V and a dc level of + 2.5 V to the counter's A input.
- Set the function selector to Frequency A 1 Hz, the attenuator to 200 mV and the ac/dc selector to ac position.
- Check that display read out is 1000 kHz.
- Set ac/dc selector to dc position and check that display read out is zero.
- Set the function selectors to period  $\approx 0.1$   $\mu$ s, the attenuator to 200 mV and the ac/dc selector to ac position.
- Check that display read out is 0.0010 ms.
- Set ac/dc selector to dc position and reset the counter.
- Check that display read out is zero.

**Main Gate and Display Time Circuits**

The three Reset Loops below are presented in the same order as they are closed during a Main Gate and Display time sequence.

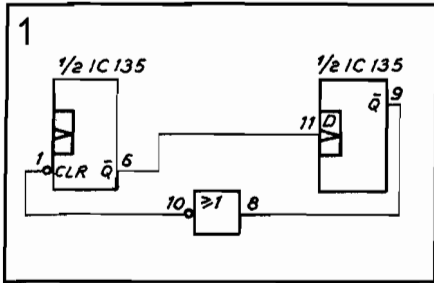

This Reset Loop makes a Low Clear in the Main Gate flip flop in the beginning of the Display Time. See time  $t_2$  in the timing diagram.

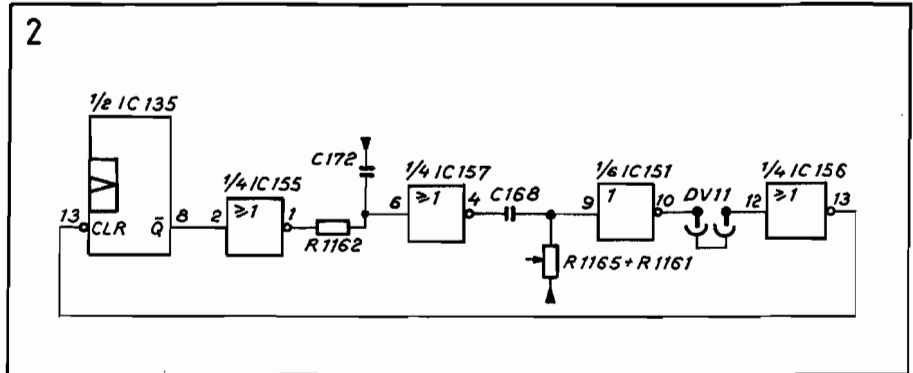

This Reset Loop makes a Low Clear in the Display flip flop when Reset arrives. See time  $t_3$  in the timing diagram.

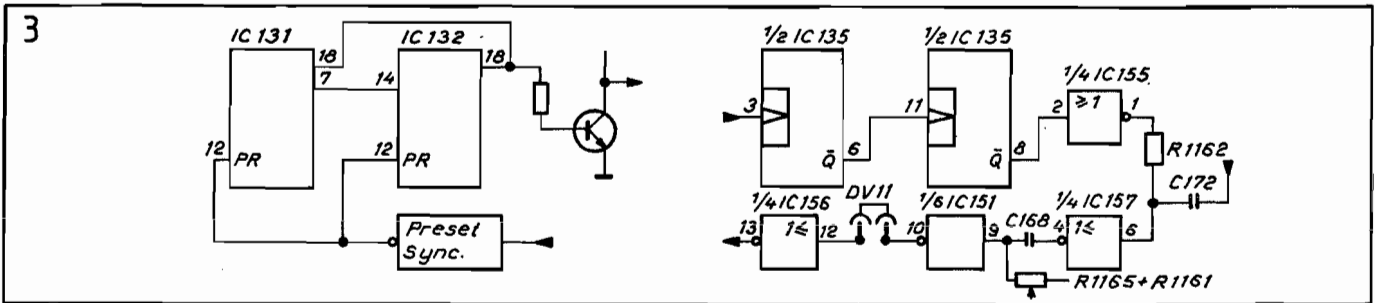

This Reset Loop makes a Low Preset in the Time Base Divider IC 131 and IC132.

**Trouble shooting the Reset Loops**

A fault in the Reset Loops can give fault symptoms in the Time Base, Main Gate and Display Time circuits. To isolate a fault in the Reset Loops use the following procedure.

- Set the controls of the counter. Function Selectors: Single Period B 0.1 ms
- Slope: positive
- Attenuator: 20 mV
- Coupling: dc
- Trigger Level: ~0.5 V
- Display Time: around mid position
- Hold Off: off

— Connect Sync Out from a pulse generator set to Single Shot mode to Input B of the counter.

— Reset the counter and measure the logic levels as shown in the Reset truth table. See time  $t_1$  in the timing diagram.

Push Single Shot once and measure the logic levels as shown in the First Single Shot truth table. See the time interval  $t_1$  to  $t_2$  in the timing diagram.

Terminal	Reset												
	Level	:1	:2	:3	:4	:5	:6	:8	:9	:10	:11	:12	:13
IC 135	H	H		H	L	H	H	L	H	H	H	H	H
IC 151								H	L				
IC 154				H	L	H							
IC 155	L	H	L	L	H	L							
IC 156	L	H	H	H	L	L	L	L	H	L	L	L	H
IC 157				H	L	L	H	H	L	H	L	L	L
IC 158	L	L	H	H	H	L					L	H	H

Terminal	First Single Shot												
	Level	:1	:2	:3	:4	:5	:6	:8	:9	:10	:11	:12	:13
IC 135	H	L		H	H	L	H	L	H	L	H	H	H
IC 151								H	L				
IC 154				H	H	L							
IC 155	L	H	L	L	H	L							
IC 156	L	H	H	H	L	L	L	L	H	L	L	L	H
IC 157				H	L	L	L	L	H	L	L	L	H
IC 158	L	L	H	H	H	L					L	H	H

Logic

Push Single Shot a second time and measure the logic levels as shown in the Second Single Shot truth table immediately after the single shot is given. See time interval  $t_2$  to  $t_3$  in the timing diagram. This, and the following truth table, might be somewhat difficult to measure because of the influence from the RC network R1156//C173, R1159//C172 and the display time R1157 + R1158//C171.

Second Single Shot

Terminal / Level	:1	:2	:3	:4	:5	:6	:8	:9	:10	:11	:12	:13
IC 135	L	H		H	L	H	L	H	H	H	L	H
IC 151								H	L			
IC 154				H	L	H						
IC 155	H	L	L	L	H	H						
IC 156	L	H	H	⌋	⌋	L	H	L	L	L	L	H
IC 157				H	H	L	H	H	L	H	L	L
IC 158	L	L	H	⌋	H	⌋				L	H	H

The last truth table shows the logic levels in the time interval  $t_3$  to  $t_1$  in the timing diagram. After the display time is out the logic levels will return to what is shown in the first truth table (Reset).

$t_3$  to  $t_1$

Terminal / Level	:1	:2	:3	:4	:5	:6	:8	:9	:10	:11	:12	:13
IC 135	L	H		H	L	H	H	L	H	H	H	L
IC 151								L	H			
IC 154				H	L	H						
IC 155	L	H	L	L	H	L						
IC 156	H	L	L	H	L	L	L	H	L	L	H	L
IC 157				L	H	H	H	H	L	H	L	L
IC 158	L	L	H	H	H	L				L	H	H

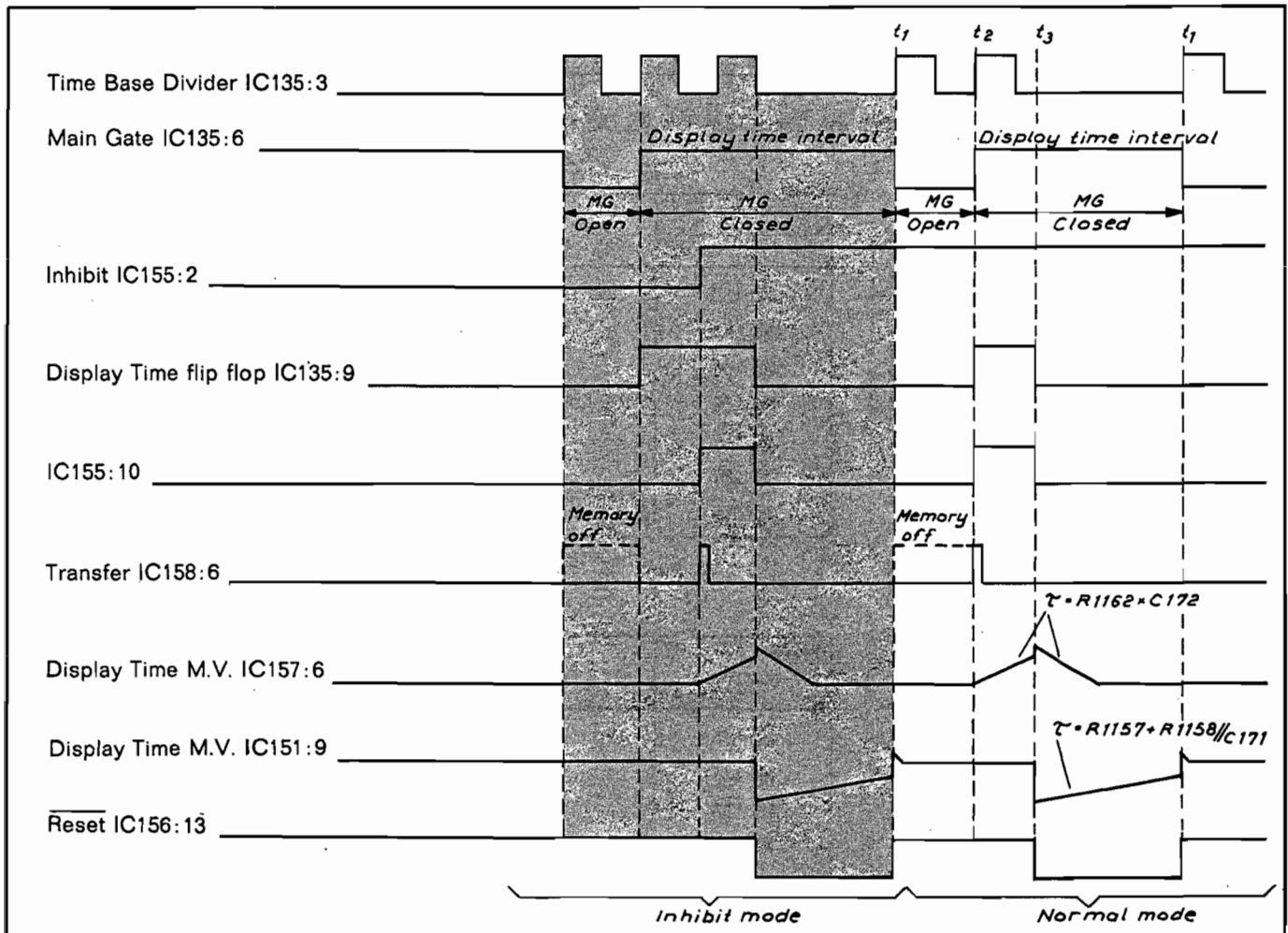



**Quad Decade IC 132...133 and IC 177...178**

The Quad Decade contains four separate decades and a flip-flop, in this application the flip-flop is not used. The Preset Input is a common input for the decades, a High level applied to this input will preset all decades to 19999.

The Reset Input is also a common input and a High level applied to this input will reset all decades to zero.

The Count Input is an exclusive input for the first decade, the signal to be counted is applied to this input. Each decade has a Carry Output which is connected to the Carry Input of the following decade.

All carry signals except from the first decade are available for measurement, in this application only Carry 10 000 is used.

The carry signal is active Low and its pulse width is equal to the repetition time of the signal at the Count Input.

Each decade has also a BCD output and a Latch.

The latch is a memory where the BCD information from the decades are stored.

The Transfer Input is a common input for the decades, a High Level applied to this input will open all latches and feed the BCD information stored in the latches to the multiplexer.

The Multiplexer is a programmable selector, the signals applied at the digit select inputs determines which latch the multiplexer will select, in this application input C is not used.

The BCD output is a tri state output, it can be logic 1, logic 0 or high-ohmic.

A High Level at Chip Enable Input will allow the multiplexer pass the BCD information in the preselected latch to the BCD output, a Low level makes the output high-ohmic.

Input A	Input B	Decade selection
L	L	Decade 1
H	L	Decade 2
L	H	Decade 3
H	H	Decade 4

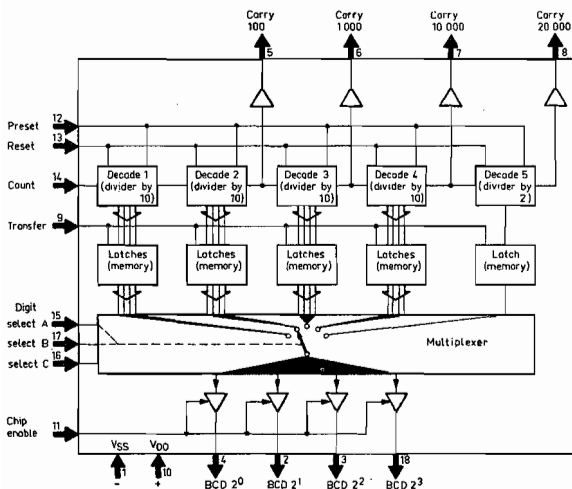

See also the Timing Diagram in the Main Gate and Display Time description.

**First Decade**

The First Decade is working up to 80 MHz and is designed with discrete integrated circuits.

It contains a divider by 10 IC 174, a memory IC 175 and a gate output with open collector IC 176.

**Decimal point setting**

The Decimal Point Signals are fed from output 1 to 6 of the Address Decoder via the Decimal Point Switch to input 6 of the 7 Segment Decoder. A table in Logic Circuits diagram shows which settings of the Function Selector will interconnect which pins of the Decimal Point Switch and thereby connect one of the decimal point outputs from the Address Decoder to the decimal point input of the 7 Segment Decoder.

**Gate Lamp Multivibrator**

This circuit extends the fastest main gate signal and makes it suitable for driving the gate lamp. The input to this circuit is the main gate signal at IC 157:3 and the output is the signal to the gate lamp at BU 101:7.

**Blanking Pulse Generator**

This circuit turns off the display between the presentation of each digit to prevent streamers between adjacent digits.

The input to this circuit is the display clock signal at R1176 and the output is the blanking signal to the emitters of TS 180...188 and IC 181:1.

Positive going pulse from the display clock will turn off TS 177 and thereby the cathode and anode voltages to the display. Test points 6 and 7 show the display clock signal and the blanking signal.

**Display**

The display is a 9 digits gas discharge display, each digit has 7 segments and a decimal point.

Each one of the digits are connected to a driving transistor which is connected to an output of the Address Decoder.

A low input from the Address Decoder turns on the transistor and its digit, this is shown in oscillogram number 8 in the logic circuit diagram.

In one scanning cycle the outputs go from High to Low in the order 10:1:2:3:4:5:6:7:9, output number 10 is connected to the least significant digit and output number 9 is connected to the most significant digit.

Only one digit will be presented at a time and before the next digit is presented a blanking pulse turns off the display. The blanking pulse is shown in oscillogram number 7 in the logic circuit diagram.

**Display Clock and Address Counter**

The Display Clock is an oscillator with a frequency of approximately 5 kHz. Test point 6 shows the output from the Display Clock to the Blanking Pulse Generator.

The Address Counter is a 1 of 10 to BCD converter and it is converting the Display Clock signal from IC 151:12 to Address Signals in BCD form.

Logic

Decades and 7 Segment Decoder

The address from the Address Counter selects which of the decades IC 176, IC 177 or IC 178 that will be presented on the display.

D bit from the Address Decoder selects the first decade, C and D bits select the first Quad Decade (2 to 5 decade) and the C bit selects the second Quad Decade (6 to 9 decade).

The A and B bits from the Address Decoder select which of the four decades in the quad decade that will be selected.

The outputs from the three decades are connected via a bus line to the 7 Segment Decoder.

Display scanning and blanking pulse generation

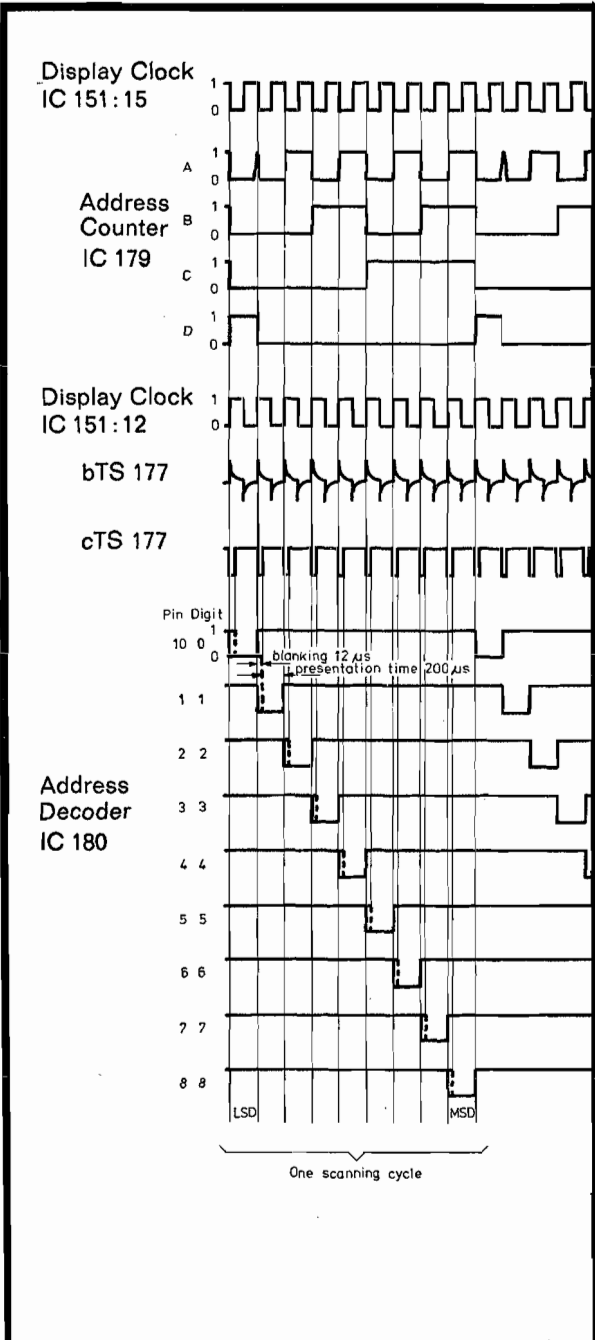

Hold Off Circuits

The Hold Off Circuits extend the closing time of the Main Gate to prevent unwanted stop signals to end the measurement.

Display presentation

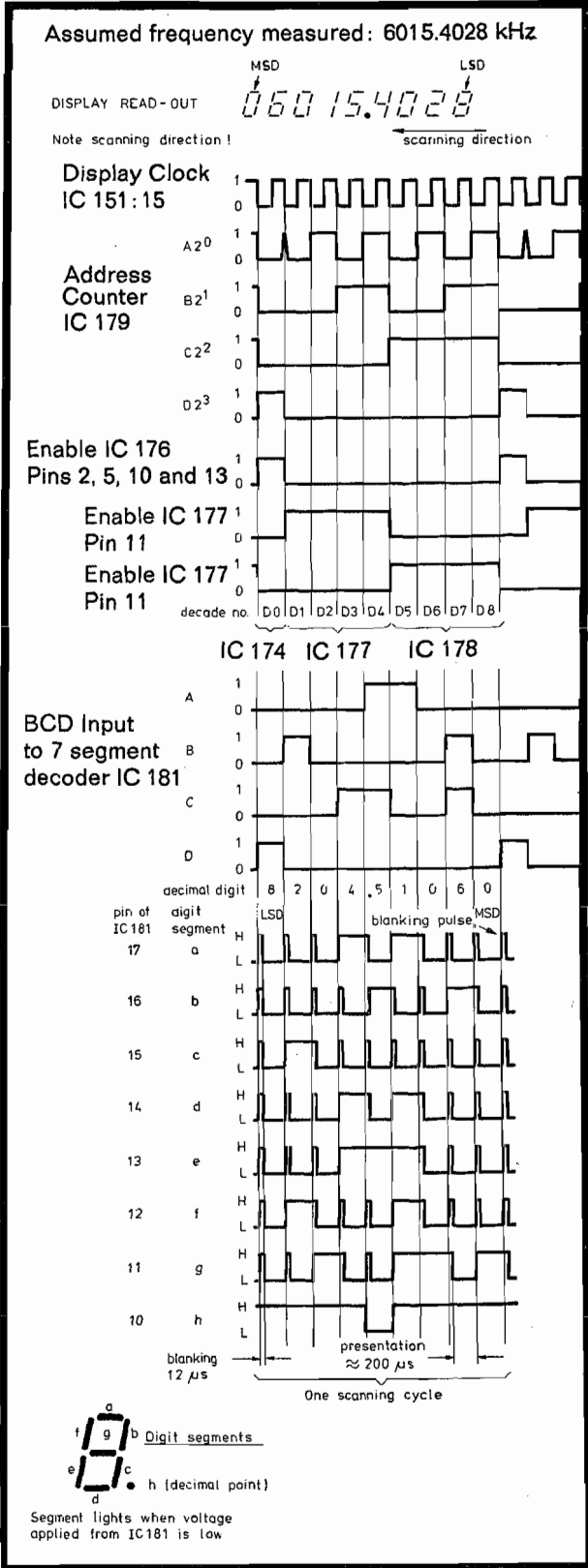

## Basic board

Ordering no	$\Omega$	%	Type	Item	Ordering no	$\Omega$	%	Type	Item
4822 110 63214	10M	10	CR25	R1003	4822 110 63098	470	5	CR25	R1134
4822 110 63189	1.2M	10	CR25	R1004	4822 110 63098	470	5	CR25	R1135
4822 110 63189	1.2M	10	CR25	R1005	4822 110 63098	470	5	CR25	R1136
4822 110 63154	56	5	CR25	R1006	4822 110 63098	470	5	CR25	R1137
5322 116 54984	68	5	PR37	R1007	4822 110 63152	47K	5	CR25	R1138
4822 110 63165	150K	5	CR25	R1008	4822 110 63125	4.7K	5	CR25	R1139
4822 110 63134	10K	5	CR25	R1009	4822 110 63107	1.0	5	CR25	R1140
4822 110 63134	10K	5	CR25	R1010	4822 110 63107	1.0	5	CR25	R1141
4822 110 63081	100	5	CR25	R1011	4822 110 63134	10K	5	CR25	R1142
4822 110 60006	390	5	CR25	R1012	4822 110 63152	47K	5	CR25	R1143
4822 110 63094	330	5	CR25	R1013	4822 110 63152	47K	5	CR25	R1144
4822 110 63116	2.2K	5	CR25	R1017	4822 110 63152	47K	5	CR25	R1145
4822 110 63092	270	5	CR25	R1018	4822 110 63152	47K	5	CR25	R1146
4822 110 63087	180	5	CR25	R1019	4822 110 63134	10K	5	CR25	R1147
4822 110 63107	1.0K	5	CR25	R1020	4822 110 63107	1.0	5	CR25	R1150
4822 110 63098	470	5	CR25	R1021	4822 110 63107	1.0	5	CR25	R1151
4822 110 63098	470	5	CR25	R1022	4822 110 60006	390	5	CR25	R1152
4822 110 63134	10K	5	CR25	R1023	4822 110 63214	10M	10	CR25	R1153
4822 110 63109	1.2K	5	CR25	R1024	4822 110 63143	22K	5	CR25	R1154
4822 110 63089	220	5	CR25	R1025	4822 110 63123	3.9K	5	CR25	R1156
4822 110 63132	8.2K	5	CR25	R1026	4822 110 63107	1.0	5	CR25	R1157
4822 110 63098	470	5	CR25	R1028	4822 110 63089	220	5	CR25	R1158
4822 110 63098	470	5	CR25	R1029	4822 110 63134	10K	5	CR25	R1160
4822 110 63121	3.3K	5	CR25	R1030	4822 110 63134	10K	5	CR25	R1161
4822 110 63214	10M	10	CR25	R1033	4822 110 63187	1M	5	CR25	R1162
4822 110 63189	1.2M	10	CR25	R1034	4822 110 63134	10K	5	CR25	R1163
4822 110 63189	1.2M	10	CR25	R1035	4822 110 63107	1.0	5	CR25	R1164
4822 110 63154	56	5	CR25	R1036	4822 110 63125	4.7K	5	CR25	R1166
5322 116 54984	68	5	PR37	R1037	4822 110 63114	1.8K	5	CR25	R1167
4822 110 63165	150K	5	CR25	R1038	4822 110 63114	1.8K	5	CR25	R1168
4822 110 63134	10K	5	CR25	R1039	4822 110 63185	820K	5	CR25	R1170
4822 110 63134	10K	5	CR25	R1040	4822 110 63098	470	5	CR25	R1171
4822 110 63081	100	5	CR25	R1041	4822 110 63098	470	5	CR25	R1172
4822 110 60006	390	5	CR25	R1042	4822 110 63114	1.8K	5	CR25	R1173
4822 110 63094	330	5	CR25	R1043	4822 110 63114	1.8K	5	CR25	R1174
4822 110 63116	2.2K	5	CR25	R1047	4822 110 63116	2.2K	5	CR25	R1175
4822 110 63092	270	5	CR25	R1048	4822 110 63125	4.7K	5	CR25	R1176
4822 110 63087	180	5	CR25	R1049	4822 110 63143	22K	5	CR25	R1177
4822 110 63105	820	5	CR25	R1050	4822 110 63129	6.8K	5	CR25	R1178
4822 110 63098	470	5	CR25	R1051	4822 110 63138	15K	5	CR25	R1180
4822 110 63098	470	5	CR25	R1052	4822 110 63138	15K	5	CR25	R1181
4822 110 63134	10K	5	CR25	R1053	4822 110 63138	15K	5	CR25	R1182
4822 110 63134	10K	5	CR25	R1054	4822 110 63138	15K	5	CR25	R1183
4822 110 63089	220	5	CR25	R1055	4822 110 63138	15K	5	CR25	R1184
4822 110 63098	470	5	CR25	R1058	4822 110 63138	15K	5	CR25	R1185
4822 110 63098	470	5	CR25	R1059	4822 110 63138	15K	5	CR25	R1186
4822 110 63121	3.3K	5	CR25	R1060	4822 110 63138	15K	5	CR25	R1187
5322 116 50524	3.01K	1	MR25	R1101	4822 110 63138	15K	5	CR25	R1188
5322 116 54011	5.62K	1	MR25	R1102	4822 110 63098	470	5	CR25	R1189
	SELECTED*		CR25	R1103	4822 110 63116	2.2K	5	CR25	R1190
4822 110 63107	1.0K	5	CR25	R1104	4822 110 63116	2.2K	5	CR25	R1191
4822 110 63121	3.3K	5	CR25	R1105	4822 110 63116	2.2K	5	CR25	R1192
4822 110 63107	1.0K	5	CR25	R1106	4822 110 63116	2.2K	5	CR25	R1193
4822 110 63107	1K			R1107	4822 110 63116	2.2K	5	CR25	R1194
4822 110 63109	1.2K	5	CR25	R1108	4822 110 63116	2.2K	5	CR25	R1195
4822 110 63116	2.2K	5	CR25	R1109	4822 110 63116	2.2K	5	CR25	R1196
4822 110 63169	220K	5	CR25	R1110	4822 110 63116	2.2K	5	CR25	R1197
4822 110 63089	220	5	CR25	R1111					
4822 110 63063	22	5	CR25	R1112					
4822 110 63089	220	5	CR25	R1113					
4822 110 63032	1.5	5	CR25	R1114					
5322 116 54963	0.18	10		R1115					
4822 110 63098	470	5	CR25	R1116					
4822 110 63089	220	5	CR25	R1117					
4822 110 63072	47	5	CR25	R1118					
4822 110 63169	220	5	CR25	R1119					
4822 110 63107	1.0K	5	CR25	R1120					
4822 110 63081	100	5	CR25	R1121					
4822 110 63081	100	5	CR25	R1122					
4822 116 30114	4.7K	NTC	NTC	R1123					
4822 113 60084	1.0	10		R1124					
4822 110 63134	10K	5	CR25	R1127					
4822 110 63107	1.0	5	CR25	R1128					
4822 110 63107	1.0	5	CR25	R1129					
4822 110 63107	1.0	5	CR25	R1130					
4822 110 63163	120K	5	CR25	R1131					
4822 110 63152	47K	5	CR25	R1132					
4822 110 63089	220	5	CR25	R1133					

Ordering no	$\Omega$	Description	Item
5322 101 14011	100	TRIMM POTM	R1014
5322 101 64017	47K	SK109	R1015
5322 101 14011	100	TRIMM POTM	R1044
5322 101 64017	47K	SK119	R1045
5322 101 94007	1M	SK101 SK102	R1165

Ordering no	F	%	V	Item
4822 121 40407	22N	10	630	C101
4822 122 31076	68P	2	100	C103
4822 122 31168	270P	2	500	C104
4822 122 31072	47P	2	100	C105
5322 122 34041	10N	+20+50	100	C106
5322 121 40323	100N	10	100	C107
5322 124 14053	33M	+10+50	10	C108
4822 121 40407	22N	10	630	C111
4822 122 31076	68P	2	100	C113

# Basic board

Ordering no	F	%	V	Item
4822 122 31168	270P	2	500	C114
4822 122 31072	47P	2	100	C115
5322 122 34041	10N	-20+50	100	C116
5322 121 40323	100N	10	100	C117
5322 124 14053	33M	-10+50	100	C118
4822 122 31081	100P	2	100	C119
5322 124 14053	33M	-10+50	10	C121
5322 122 34041	10N	-20+50	100	C122
5322 124 14053	33M	-10+50	10	C123
5322 122 34041	10N	-20+50	100	C124
5322 122 34041	10N	-20+50	100	C125
5322 122 34041	10N	-20+50	100	C126
5322 122 34041	10N	-20+50	100	C127
5322 122 34041	10N	-20+50	100	C128
5322 122 34041	10N	-20+50	100	C129
4822 121 40407	22N	10	630	C130
4822 122 31036	2.2P	2	100	C131
5322 122 34041	10N	-20+50	100	C132
5322 124 14053	33M	-10+50	10	C133
5322 124 14053	33M	-10+50	10	C134
5322 122 34041	10N	-20+50	100	C136
5322 122 34041	10N	-20+50	100	C137
4822 124 10197	47M	-10+50	6.3	C139
4822 124 10197	47M	-10+50	6.3	C140
4822 121 40232	220N	10	100	C141
5322 122 34041	10N	-20+50	100	C144
4822 122 30113	180P	2	100	C146
5322 122 34041	10N	-20+50	100	C147
5322 122 34041	10N	-20+50	100	C150
4822 122 31081	100P			C151
4822 124 20534	680M	-10+50	40	C152
4822 121 40104	150N	10	250	C153
4822 124 20586	150M	-10+50	16	C154
4822 124 20589	220M	-10+50	10	C155
4822 124 20589	220M	-10+50	10	C156
4822 124 20589	220M	-10+50	10	C157
4822 124 20499	22M	-10+50	63	C160
4822 124 20534	680M	-10+50	40	C161
5322 122 34041	10N	-20+50	100	C162
5322 124 24116	1M			C163
4822 122 31165	330P	10	100	C164
5322 124 14075	1M	-10+50	25	C165
5322 122 34041	10N	-20+50	100	C166
4822 121 40232	220N	10	100	C167
5322 124 14066	10M	-10+50	6.3	C168
5322 122 34041	10N	-20+50	100	C169
4822 122 31081	100P	2	100	C170
5322 121 40323	100N	10	100	C172
5322 121 40323	100N	10	100	C176
4822 122 30114	2.2N	10	100	C178
5322 122 34041	10N	-20+50	100	C179
4822 121 41156	68N	10	250	C180
5322 121 44137	68N	10	250	C181
5322 121 44137	68N	10	250	C182
5322 121 44137	68N	10	250	C183
5322 121 44137	68N	10	250	C184
5322 121 44137	68N	10	250	C185
5322 121 44137	68N	10	250	C186
5322 121 44137	68N	10	250	C187
5322 121 44137	68N	10	250	C188
4822 121 40104	150N	10	250	C189

Ordering no	F	V	Item
5322 125 54024	2-9P	300	C102
5322 125 54024	2-9P	300	C112

Ordering no	Description	Item
5322 130 44578	E411 SILICONIX	TS101
5322 130 44578	E411 SILICONIX	TS102
5322 130 44435	2N5770	TS103
5322 130 44435	2N5770	TS104
5322 130 44215	MPSL08	TS105
5322 130 44215	MPSL08	TS106
5322 130 40407	2N2369	TS142
4822 130 40855	BC337	TS146

Ordering no	Description	Item
5322 130 24035	BT100A-02	TS150
5322 130 40482	BRY39	TS151
4822 130 40855	BC337	TS152
5322 130 44417	B0X35	TS153
5322 130 40482	BRY39	TS154
5322 130 44418	BF256A	TS155
4822 130 40937	BC548B	TS156
5322 130 44256	BC557	TS177
5322 130 44247	BSS68	TS180
5322 130 44247	BSS68	TS181
5322 130 44247	BSS68	TS182
5322 130 44247	BSS68	TS183
5322 130 44247	BSS68	TS184
5322 130 44247	BSS68	TS185
5322 130 44247	BSS68	TS186
5322 130 44247	BSS68	TS187
5322 130 44247	BSS68	TS188
5322 209 85408	MC1651L	1C101
5322 209 84643	MC10102P	1C102
5322 209 85409	GXB10110	1C103
5322 209 84825	MC10216P	1C104
5322 209 84183	SN74S74N	1C125
5322 209 84183	SN74S74N	1C126
5322 209 84304	SN75107AN	1C127
5322 209 85406	N74LS54A	1C128
5322 209 84628	N7403A	1C129
5322 209 84528	SN7400N	1C130
5322 209 84722	GZF1201P MOS	1C131
5322 209 84722	GZF1201P MOS	1C132
5322 209 85001	SN74LS157N	1C133
5322 209 84996	SN74LS10N	1C134
5322 209 84183	SN74LS74N	1C135
5322 209 84724	SN74S64N	1C136
5322 209 85407	N74S02A	1C137
5322 209 84655	723PC	1C150
5322 209 85085	F34049PC SELECTED	1C151
5322 209 84983	SN74LS00N	1C152
5322 209 85412	CD4093BE MOS	1C153
5322 209 84983	SN74LS00N	1C154
5322 209 84993	SN74LS02N	1C155
5322 209 84993	SN74LS02N	1C156
5322 209 84976	1CF4001PC	1C157
5322 209 84983	SN74LS00N	1C158
5322 209 84984	SN74LS04N	1C159
5322 209 85411	74S196	1C174
5322 209 80059	74LS75	1C175
5322 209 84529	SN7403N	1C176
5322 209 84722	GZF1201P MOS	1C177
5322 209 84722	GZF1201P MOS	1C178
5322 209 80072	SN7490AN	1C179
5322 209 80142	SN7442AN	1C180
5322 209 84723	DM8884AN	1C181
5322 111 94015	6X1.0K	1C190
5322 111 94015	6X1.0K	1C191
5322 111 94031	6X47K	1C192
5322 111 94031	6X47K	1C193
5322 111 94012	6X6.8K	1C194
5322 111 94012	6X6.8K	1C195
5322 111 94031	6X47K	1C196
5322 111 94012	6X6.8K	1C197
5322 111 94026	6X470K	1C198
4822 130 30509	BZY88-C4V3	GR101
5322 130 30613	BAW62	GR102
5322 130 30613	BAW62	GR103
4822 130 30509	BZY88-C4V3	GR104
5322 130 34563	BZX79-C2V7	GR105
5322 130 30613	BAW62	GR106
5322 130 34563	BZX79-C2V7	GR107
5322 130 30613	BAW62	GR108
4822 130 30509	BZY88-C4V3	GR111
5322 130 30613	BAW62	GR112
5322 130 30613	BAW62	GR113
4822 130 30509	BZY88-C4V3	GR114
5322 130 34563	BZX79-C2V7	GR115
5322 130 30613	BAW62	GR116
5322 130 34563	BZX79-C2V7	GR117
5322 130 30613	BAW62	GR118

## Basic board

Ordering no	Description	Item
5322 130 30613	BAW62	GR121
5322 130 34047	BZX75-C1V4	GR122
5322 130 30613	BAW62	GR125
5322 130 30613	BAW62	GR138
5322 130 30613	BAW62	GR139
5322 130 30613	BAW62	GR140
5322 130 30613	BAW62	GR141
5322 130 30613	BAW62	GR142
5322 130 30613	BAW62	GR143
5322 130 30613	BAW62	GR144
5322 130 30613	BAW62	GR145
5322 130 30594	BAV10	GR150
5322 130 30774	BZX79-C10	GR151
5322 130 30594	BAV10	GR152
5322 130 34401	BZX70-C56	GR153
5322 130 30392	BZY88-C3V3	GR154
4822 130 30868	BY207	GR155
4822 130 30839	BY206	GR156
4822 130 30868	BY210-400	GR157
4822 130 30868	BY210-400	GR158
4822 130 30839	BY206	GR159
5322 130 34167	BZX79-B6V2	GR160
4822 130 30868	BY210-400	GR161
5322 130 30192	BY126	GR163
5322 130 30414	BY164	GR167
5322 130 30613	BAW62	GR170
5322 130 34049	BZX75-C2V1	GR171
5322 130 30613	BAW62	GR172
5322 130 30613	BAW62	GR173
5322 130 30613	BAW62	GR175
5322 130 34189	BAW20	GR180
5322 130 34189	BAW20	GR181
5322 130 34189	BAW20	GR182
5322 130 34189	BAW20	GR183
5322 130 34189	BAW20	GR184
5322 130 34189	BAW20	GR185
5322 130 34189	BAW20	GR186
5322 130 34189	BAW20	GR187
5322 130 34189	BAW20	GR188
5322 130 34166	BZX79-C51	GR189

Ordering no	Description	Item
4822 252 20001	THERMAL FUSE	VL101
5322 131 94042	DISPLAY	B101
5322 462 34127	GUIDE RAIL	FOR U1
5322 158 10289	INDUCTANCE 0.68MH	L101
5322 158 10289	INDUCTANCE 0.68MH	L102
5322 158 10243	INDUCTANCE 100MH	L103
5322 158 10284	INDUCTANCE 47MH	L104
5322 158 10284	INDUCTANCE 47MH	L105
5322 158 10052	CHOKE	L150
4822 526 10097	FXC BEAD	L151
5322 158 10052	CHOKE	L152

Ordering no	Description	Item
5322 456 14054	TEXT PLATE	PM6622
5322 456 14055	TEXT PLATE	PM6624
5322 456 14056	TEXT PLATE	PM6625
5322 450 64059	WINDOW	
5322 414 34076	FUNCTION KNOB	SK105
5322 414 74019	COVER FUNCTION KNOB	SK105
5322 414 34091	DISPLAY KNOB	SK101
5322 414 74015	COVER DISPLAY KNOB	SK101
5322 414 34091	HOLD OFF KNOB	SK403
5322 414 74015	COVER HOLD OFF KNOB	SK403
5322 414 34091	TRIGGER KNOBS	
5322 414 74015	COVER TRIGGER KNOBS	
5322 414 14011	PUSH BUTTON KNOBS	
5322 267 10004	INPUT SOCKETS A B	BU1 BU2

Ordering no	Description	Item
5322 267 34059	EXT BATTERY SOCKET	BU21
5322 267 34059	EXT BATTERY SOCKET	BU22
5322 265 30066	MAINS INPUT SOCKET	BU23
5322 267 10004	INPUT 0-10MHZ OUT	BU24
5322 267 10004	EXT. RESET	BU25
5322 267 10004	GATE OPEN	BU27
5322 277 24017	INT EXT STD SWITCH	SK22

Ordering no	Description	Item
5322 256 34031	FUSEHOLDER	VL150
5322 255 44107	IC HOLDER 16 PINS	D.I.L
5322 255 44112	IC HOLDER 18 PINS	D.I.L
5322 255 40089	TRANSISTOR HOLDER	TO 18-3
5322 255 40089	TRANSISTOR HOLDER	TO 18-4
5322 265 54006	TRANSISTOR HOLDER	TS153
5322 265 54006	FEMALE CONNECTOR	BU 102
5322 265 54018	MALE CONNECTOR	BU 102
5322 265 44064	MALE CONNECTOR	BU103
5322 265 44064	MALE CONNECTOR	BU104
5322 265 44064	MALE CONNECTOR	BU105
5322 255 44107	FEMALE CONNECTOR	BU106
5322 265 54006	FEMALE CONNECTOR	BU107
5322 101 94007	COMBINED SWITCH	SK101
5322 101 94007	COMBINED SWITCH	SK102
5322 276 14117	PUSH BUTTON SWITCH	SK103
5322 276 14117	PUSH BUTTON SWITCH	SK104
5322 273 74008	ROTARY SWITCH	SK105
5322 276 14117	PUSH BUTTON SWITCH	SK106
5322 276 14117	PUSH BUTTON SWITCH	SK107
5322 276 14117	PUSH BUTTON SWITCH	SK108
5322 101 64017	COMBINED SWITCH	SK109
5322 276 14117	PUSH BUTTON SWITCH	SK110
5322 276 14117	PUSH BUTTON SWITCH	SK116
5322 276 14117	PUSH BUTTON SWITCH	SK117
5322 276 14117	PUSH BUTTON SWITCH	SK118
5322 101 64017	COMBINED SWITCH	SK119
5322 276 14117	PUSH BUTTON SWITCH	SK120
5322 277 24006	SLIDE SWITCH	SK121
5322 146 14079	MAINS TRANSFORMER	T101
5322 142 64027	DC-DC TRANSFORMER	T102
4822 253 20022	FUSE 1.6A FAST	VL150

Ordering no	Description	Qty
5322 498 54048	HANDLE ARM	2
5322 498 54054	HANDLE PROFILE	1
5322 520 34164	BEARING BUSH	2
5322 414 64053	CAP HANDLE ARM	2
5322 447 84467	TOP COVER	1
5322 447 84466	BOTTOM COVER	1
5322 466 85335	FRONT ORNAMENT	1
5322 459 24054	REAR ORNAMENT	1
5322 462 44181	REAR FOOT	4
5322 462 44179	BOTTOM FOOT	4
4822 462 70497	PLUG BOTTOM FOOT	4

Ordering no	Description	Item
5322 321 24389	CABLE COMPLETE	U3 TO U1
5322 268 24073	TEST SOCKET	BU302
5322 268 24073	TEST SOCKET	BU303
5322 130 34562	LD35/II	GR301
5322 130 34562	LD35/II	GR302
5322 130 34562	LD35/II	GR303
5322 130 34562	LD35/II	GR304
5322 130 34562	LD35/II	GR305
5322 130 34562	LD35/II	GR306
5322 130 34562	LD35/II	GR307

Ordering no	Description	Item
5322 321 24391	CABLE COMPLETE	U4 TO U1
5322 277 24006	SLIDE SWITCH	SK401
5322 277 24006	SLIDE SWITCH	SK402
5322 101 54008	COMBINED	SK403-SK404R401
5322 121 54118	CAPACITOR 150NF 63V C401	

Prescaler PM 6624

Ordering no	$\Omega$	%	Type	Item
4822 116 51142	150	5	PR37	R201
5322 116 54396	68	5	PR52	R202
5322 116 54396	68	5	PR52	R203
5322 116 50417	162	5	MR25	R204
4822 111 30328	330	5	CR16	R205
4822 110 63125	4.7K	5	CR25	R206
4822 110 63147	33K	5	CR25	R207
4822 110 63107	1K	5	CR25	R208
4822 110 63125	4.7K	5	CR25	R209
4822 110 63152	47K	5	CR25	R210
4822 110 63107	1K	5	CR25	R211
4822 110 63138	15K	5	CR25	R212
4822 111 30067	33	5	CR16	R213
4822 110 63134	10K	5	CR25	R214
4822 110 63141	18K	5	CR25	R215
4822 110 63101	560	5	CR25	R216
4822 111 30264	2.7K	5	CR16	R217
4822 111 30323	270	5	CR16	R218
4822 111 30272	680	5	CR16	R219
4822 111 30245	47	5	CR16	R220
4822 111 30347	10	5	CR16	R221
4822 110 63161	100K	5	CR25	R222
4822 110 63116	2.2K	5	CR25	R223
4822 110 63125	4.7K	5	CR25	R224
4822 110 63134	10K	5	CR25	R225
4822 110 63098	470	5	CR25	R226
4822 110 63116	2.2K	5	CR25	R227
4822 110 63054	10	5	CR25	R228
4822 111 30272	680	5	CR25	R229
4822 110 63098	470	5	CR25	R230
4822 110 63116	2.2K	5	CR25	R231
4822 110 63125	4.7K	5	CR25	R238

Ordering no	Description	Item
5322 158 14119	COIL	L201
5322 158 14119	COIL	L202
5322 158 10276	INDUCTANCE 4.7MH	L203
5322 158 14119	COIL	L204
4822 526 10025	FXC BEAD	L205
4822 526 10025	FXC BEAD	L207
4822 526 10025	FXC BEAD	L208
4822 526 10025	FXC BEAD	L209
4822 526 10025	FXC BEAD	L210
5322 526 14019	BEAD	L211
5322 265 54006	FEMALE CONNECTOR	BU201 1
5322 265 54018	MALE CONNECTOR	BU201 1
5322 535 94711	DISTANCE PIECE	FOR U2 2
5322 462 34054	GUIDE RAIL	FOR U2 2
5322 255 44122	IC HOLDER 14 PINS	DIL 1
5322 255 40089	TRANSISTOR HOLDER	TO18-3 2

Ordering no	F	%	V	Item
4822 122 31177	470P	10	100	C201
4822 122 31177	470P	10	100	C202
4822 122 31177	470P	10	100	C203
4822 122 31177	470P	10	10	C204
4822 122 30043	10N	-20+80	63	C205
5322 122 34043	47P	2	50	C206
4822 122 31175	1N	10	100	C207
5322 124 14079	68M		6.3	C208
4822 122 31043	3.9P	2	63	C209
4822 122 31173	220P	10	100	C211
4822 122 30094	220P	10	100	C212
4822 122 31177	470P	10	100	C213
4822 122 30043	10N	-20+80	63	C214
5322 124 14036	15M		16	C215
4822 122 31175	1N	10	100	C216
5322 122 34043	47P	2	100	C217
4822 122 31072	47P	10	100	C218
4822 122 30043	10N	-20+80	63	C219
4822 122 31175	1N	10	100	C220
5322 122 34043	47P	2	50	C221
4822 122 31175	1N	10	100	C222
4822 122 31175	1N	10	100	C223
5322 124 14079	68M		6.3	C224
4822 122 30043	10N	-20+80	63	C225
4822 122 31072	47P	10	100	C226
4822 122 31173	220P	10	100	C227

Ordering no	Description	Item
5322 130 34283	HP5082-2835	GR203
5322 130 34283	HP5082-2835	GR204
5322 130 34364	BA379	GR205
5322 130 34364	BA379	GR206
5322 130 34364	BA379	GR207
5322 130 30613	BAW62	GR208
5322 130 34283	HP5082-2835	GR209
5322 130 34283	HP5082-2835	GR210
5322 130 30666	BZX79-C7V5	GR211
5322 209 85414	QM334	IC201
5322 209 85414	QM334	IC202
5322 209 84721	SP670B	IC203
5322 209 84163	SN72741P	IC204
5322 209 84163	SN72741P	IC205
5322 209 84163	SN7474N	IC206
5322 209 84165	SN7474N	IC207
4822 130 40937	BC548B	TS201
5322 130 40348	BC178B	TS202
5322 130 44179	BFR90	TS203
4822 130 40937	BC548B	TS204
5322 130 40343	BC108B	TS205
5322 130 34364	BA379	GR201
5322 130 34364	BA379	GR202

Prescaler PM 6625

Ordering no	$\Omega$	%	Type	Item
5322 116 54393	150	5	PR52	R201
5322 116 54396	68	5	PR52	R202
5322 116 54396	68	5	PR52	R203
5322 116 50417	162	5	MR25	R204
4822 111 30328	330	5	CR16	R205
4822 110 63125	4.7K	5	CR25	R206
4822 110 63147	33K	5	CR25	R207
4822 110 63107	1K	5	CR25	R208
4822 110 63125	4.7K	5	CR25	R209
4822 110 63152	47K	5	CR25	R210
4822 110 63107	1K	5	CR25	R211
4822 110 63138	15K	5	CR25	R212
4822 111 30348	27	5	CR16	R213
4822 110 63134	10K	5	CR25	R214
4822 110 63141	18K	5	CR25	R215
4822 110 63094	330	5	CR25	R216
4822 111 30265	2.2K	5	CR16	R217
4822 111 30331	470	5	CR16	R218
4822 111 30312	4.7K	5	CR16	R219
4822 111 30327	220	5	CR16	R220
4822 111 30347	10	5	CR16	R221
4822 110 63161	100K	5	CR25	R222
4822 110 63116	2.2K	5	CR25	R223
4822 110 63116	2.2K	5	CR25	R224
4822 110 63134	10K	5	CR25	R225
4822 110 63098	470	5	CR25	R226
4822 110 63116	2.2K	5	CR25	R227
4822 110 63054	10	5	CR25	R228
4822 111 30272	680	5	CR16	R229
4822 110 63098	470	5	CR25	R230
4822 110 63116	2.2K	5	CR25	R231
4822 111 30324	100	5	CR16	R233
4822 111 30328	330	5	CR16	R234
4822 111 30328	330	5	CR16	R235
4822 110 63098	470	5	CR16	R236
4822 110 63069	39	5	CR16	R237
4822 110 63125	4.7K	5	CR16	R238

Ordering no	F	%	V	Item
5322 122 34071	470P	20	50	C201
5322 122 34071	470P	20	50	C202
5322 122 34071	470P	20	50	C203
5322 122 34071	470P	20	50	C204
4822 122 30043	10N	-20+80	63	C205
5322 122 34043	47P	10	50	C206
4822 122 31175	1N	10	100	C207
5322 124 14079	68M	-10+50	6.3	C208
5322 122 34043	47P	10	50	C209
4822 122 31173	220P	10	100	C210
4822 122 31173	220P	10	100	C211
4822 122 31173	220P	10	100	C212
5322 122 34071	470P	10	50	C213
4822 122 30043	10N	-20+80	63	C214
5322 124 14036	15M	-10+50	16	C215
4822 122 31175	1N	10	100	C216
5322 122 34071	470P	20	50	C217
5322 122 34042	12P	10	50	C218
4822 122 30043	10N	-20+80	63	C219
4822 122 31175	1N	10	100	C220
4822 122 30043	10N	-20+80	63	C221
5322 122 34043	47P	10	50	C222
5322 122 34071	470P	20	50	C223
5322 124 14079	68M	-10+50	6.3	C224
5322 122 34071	470P	10	50	C225
4822 122 31072	47P	2	100	C226
5322 122 34071	470P	20	50	C227
4822 122 31072	47P	2	100	C228
4822 122 30043	10N	-20+80	63	C229
5322 122 34043	47P	10	50	C230
4822 122 31054	10P	2	100	C231

Ordering no	Description	Item
5322 158 14119	COIL	L201
5322 158 14119	COIL	L202
5322 158 10276	INDUCTANCE 4.7MH	L203
5322 158 14119	COIL	L204
5322 158 14119	COIL	L205
5322 158 14119	COIL	L206
5322 158 14119	COIL	L207
5322 158 14119	COIL	L208
5322 157 44024	COIL	L209
4822 526 10025	FXC BEAD	L210
4822 526 10025	FXC BEAD	L211
4822 526 10025	FXC BEAD	L212
4822 526 10025	FXC BEAD	L214
5322 265 54006	FEMALE CONNECTOR	BU201 1
5322 265 54018	MALE CONNECTOR	BU201 1
5322 535 94711	DISTANCE PIECE FOR U2	2
5322 255 44122	IC HOLDER 14 PINS DIL	1
5322 255 40089	TRANSISTOR HOLDER TO18-3	2
5322 462 34054	GUIDE RAIL	2

Ordering no	Description	Item
5322 209 85414	OM334	1C201
5322 209 85414	OM334	1C202
5322 209 84725	SP8616B	1C203
5322 209 84165	SN72741P	1C204
5322 209 84165	SN72741P	1C205
5322 209 84165	SN7474N	1C206
5322 209 84165	SN7474N	1C207
5322 209 84729	SP8600B	1C208
4822 130 40937	BC548B	TS201
5322 130 40348	BC178B	TS202
5322 130 44179	BFR90	TS203
4822 130 40937	BC548B	TS204
5322 130 40343	BC108B	TS205
5322 130 44435	2N5770	TS206
5322 130 34364	BA379	GR201
5322 130 34364	BA379	GR202
5322 130 34283	HP5082-2835	GR203
5322 130 34283	HP5082-2835	GR204
5322 130 34364	BA379	GR205
5322 130 34364	BA379	GR206
5322 130 34364	BA379	GR207
5322 130 30613	BAW62	GR208
5322 130 34283	HP5082-2835	GR209
5322 130 34283	HP5082-2835	GR210
5322 130 30666	BZX79-C7V5	GR211
5322 130 34364	BA379	GR212
5322 130 30666	BZX79-C7V5	GR213
5322 130 30411	BZX79-C3V9	GR214
5322 130 30411	BZX79-C3V9	GR215

**CODING SYSTEM OF FAILURE REPORTING FOR QUALITY  
ASSESSMENT OF T & M INSTRUMENTS  
(excl. potentiometric recorders)**

The information contents of the coded failure description is necessary for our computerized processing of quality data.

Since the reporting of repair and maintenance routines must be complete and exact, we give you an example of a correctly filled-out PHILIPS SERVICE Job sheet.

①	②	③	/Version	④
Country	Day Month Year	Typenumber		Factory/Serial no.
3 2	1 5 0 4 7 5	O P M 3 2 6 0 0 2		D O 0 0 7 8 3

**CODED FAILURE DESCRIPTION**

⑤	⑥																																																																
Nature of call	Location	Component/sequence no.	Category	⑦	Job completed	⑧	Working time																																																										
<input type="checkbox"/> Installation <input type="checkbox"/> Pre sale repair <input type="checkbox"/> Preventive maintenance <input checked="" type="checkbox"/> Corrective maintenance <input type="checkbox"/> Other	<table border="1" style="width: 100%; height: 100%; border-collapse: collapse;"> <tr><td> </td><td> </td><td> </td><td> </td></tr> <tr><td> </td><td> </td><td> </td><td> </td></tr> <tr><td>0 0</td><td>2 1</td><td> </td><td> </td></tr> <tr><td> </td><td> </td><td> </td><td> </td></tr> <tr><td> </td><td> </td><td> </td><td> </td></tr> </table>									0 0	2 1											<table border="1" style="width: 100%; height: 100%; border-collapse: collapse;"> <tr><td>T</td><td>S</td><td>0</td><td>6</td><td>0</td><td>7</td></tr> <tr><td>R</td><td>0</td><td>0</td><td>6</td><td>3</td><td>1</td></tr> <tr><td>9</td><td>9</td><td>0</td><td>0</td><td>0</td><td>1</td></tr> <tr><td> </td><td> </td><td> </td><td> </td><td> </td><td> </td></tr> <tr><td> </td><td> </td><td> </td><td> </td><td> </td><td> </td></tr> </table>	T	S	0	6	0	7	R	0	0	6	3	1	9	9	0	0	0	1													<table border="1" style="width: 100%; height: 100%; border-collapse: collapse;"> <tr><td>5</td></tr> <tr><td>2</td></tr> <tr><td>4</td></tr> <tr><td> </td></tr> <tr><td> </td></tr> </table>	5	2	4			<input type="checkbox"/> <input checked="" type="checkbox"/>	<input type="checkbox"/>	<table border="1" style="width: 100%; height: 100%; border-collapse: collapse;"> <tr><td> </td><td> </td><td>1</td><td>2</td></tr> </table> Hrs			1	2
0 0	2 1																																																																
T	S	0	6	0	7																																																												
R	0	0	6	3	1																																																												
9	9	0	0	0	1																																																												
5																																																																	
2																																																																	
4																																																																	
		1	2																																																														

Detailed description of the information to be entered in the various boxes:

①Country: 3 2 = Switzerland

②Day Month Year 1 5 0 4 7 5 = 15 April 1975

③Type number/Version O P M 3 2 6 0 0 2 = Oscilloscope PM 3260, version 02 (in later oscilloscopes this number is placed in front of the serial no)

④Factory/Serial number D O 0 0 7 8 3 = DO 783 These data are mentioned on the type plate of the instrument

⑤ Nature of call: Enter a cross in the relevant box

⑥ Coded failure description

**Location**

--	--	--	--

These four boxes are used to isolate the problem area. Write the code of the part in which the fault occurs, e.g. unit no or mechanical item no of this part (refer to 'PARTS LISTS' in the manual).

Example: 0001 for Unit 1  
000A for Unit A  
0075 for item 75

If units are not numbered, do not fill in the four boxes; see Example Job sheet.

**Component/sequence no.**

--	--	--	--	--	--

These six boxes are intended to pinpoint the faulty component. A. Enter the component designation as used in the circuit diagram. If the designation is alfa-numeric, the letters must be written (starting from the left) in the two left-hand boxes and the figures must be written (in such a way that the last digit occupies the right-most box) in the four right-hand boxes. B. Parts not identified in the circuit diagram:

- 990000 Unknown/Not applicable
- 990001 Cabinet or rack (text plate, emblem, grip, rail, graticule, etc.)
- 990002 Knob (incl. dial knob, cap, etc.)
- 990003 Probe (only if attached to instrument)
- 990004 Leads and associated plugs
- 990005 Holder (valve, transistor, fuse, board, etc.)
- 990006 Complete unit (p.w. board, h.t. unit, etc.)
- 990007 Accessory (only those without type number)
- 990008 Documentation (manual, supplement, etc.)
- 990009 Foreign object
- 990099 Miscellaneous

**Category**

--

- 0 Unknown, not applicable (fault not present, intermittent or disappeared)
- 1 Software error
- 2 Readjustment
- 3 Electrical repair (wiring, solder joint, etc.)
- 4 Mechanical repair (polishing, filing, remachining, etc.)
- 5 Replacement (of transistor, resistor, etc.)
- 6 Cleaning and/or lubrication
- 7 Operator error
- 8 Missing items (on pre-sale test)
- 9 Environmental requirements are not met

⑦ Job completed: Enter a cross when the job has been completed.

⑧ Working time: Enter the total number of working hours spent in connection with the job (excluding travelling, waiting time, etc.), using the last box for tenths of hours.

1 2 = 1,2 working hours (1 h 12 min.)



# Prescaler PM 6624

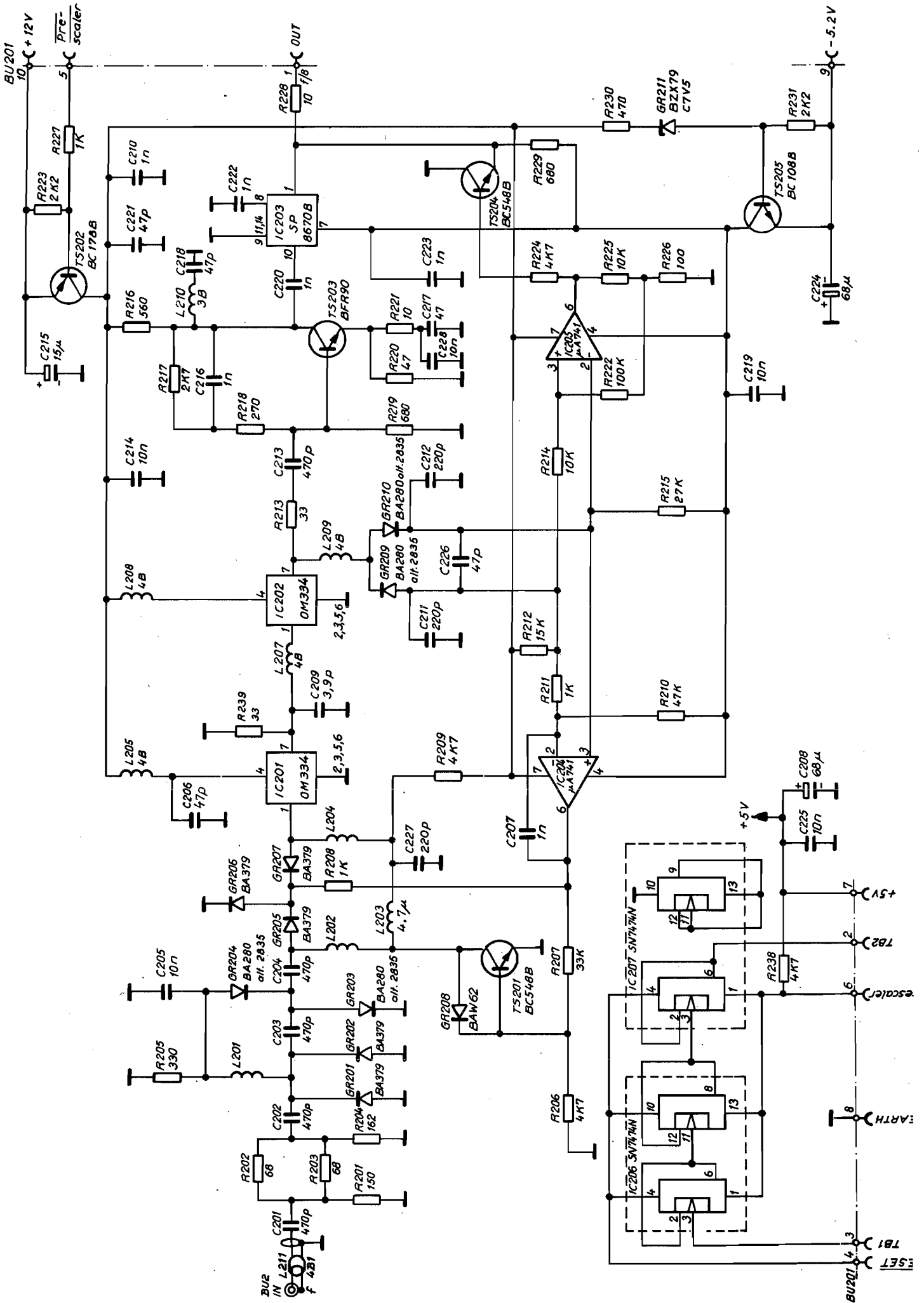

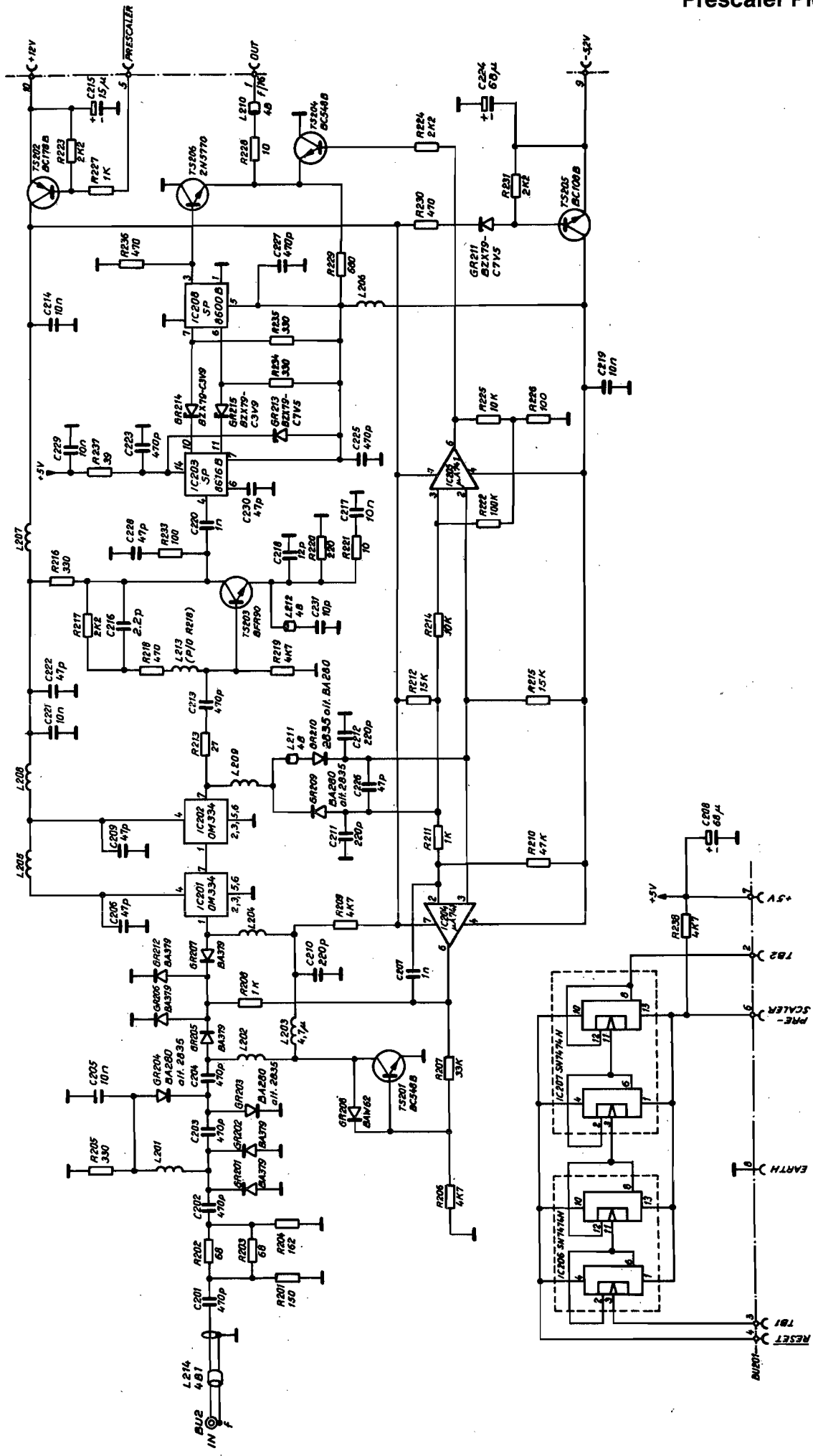

Standard symbols for logic elements

Circuit	I.E.C.	DIN norm 40700	American standard	Boolean function
AND				$X = AB$
OR				$X = A + B$
NAND				$X = \overline{AB}$
NOR				$X = \overline{A + B}$
NAND with one inverting input				$X = \overline{A\overline{B}}$
NOR with one inverting input				$X = \overline{\overline{A} + B}$
INHIBIT GATE				$X = (A + B)\overline{C}$
EXCLUSIVE OR				$X = A\overline{B} + \overline{A}B$
COMPARATOR				$X = AB + \overline{A}\overline{B}$
Distributed AND				
Distributed OR				
DELAY				
FLIP-FLOP				

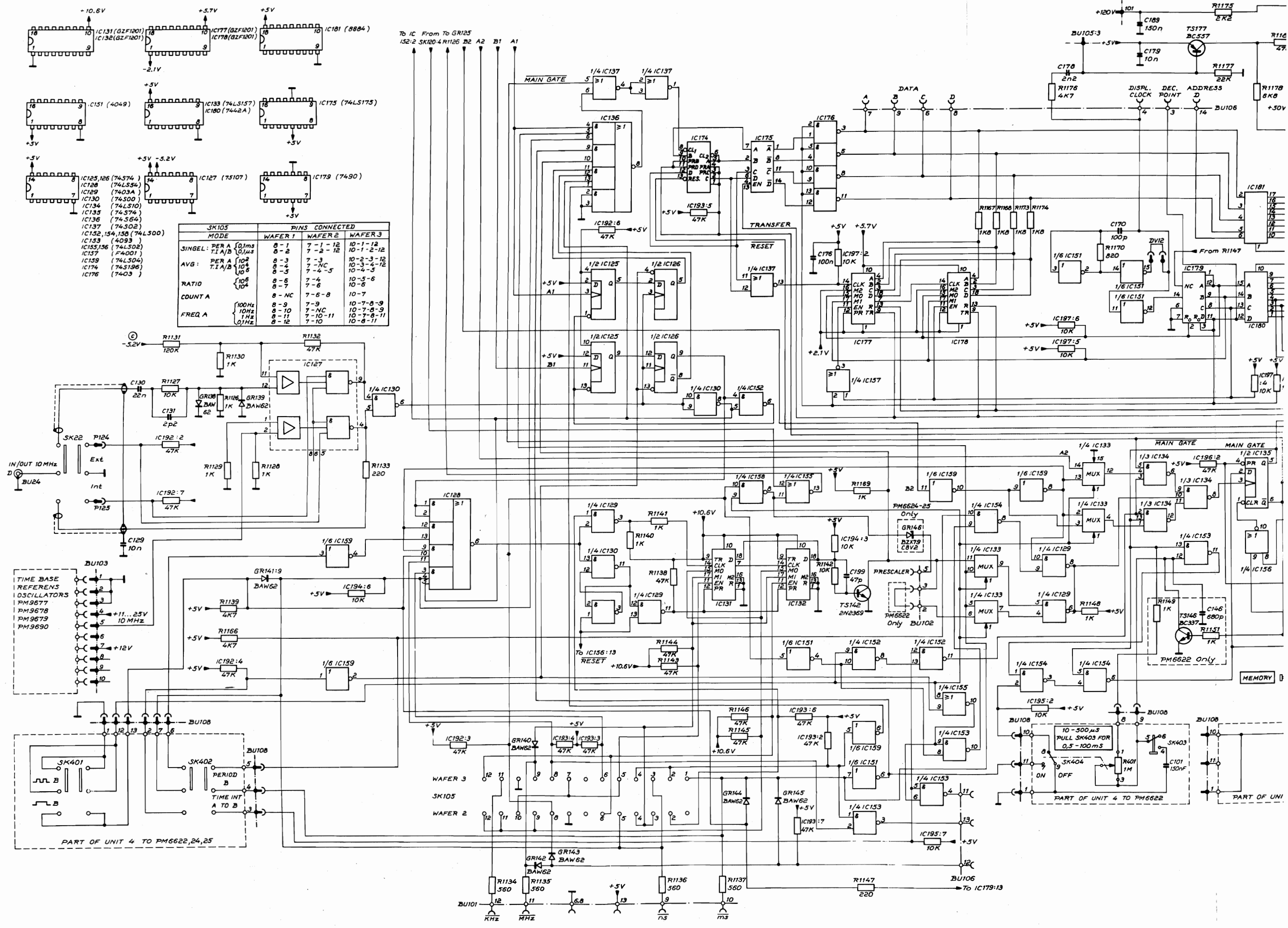

MODE	PINS CONNECTED			
	WAFER 1	WAFER 2	WAFER 3	
SINGEL:	PER A (0.1ms)	8-1	7-1-12	10-1-12
	T.I.A/B (0.1ms)	8-2	7-2-12	10-1-2-12
AVG:	PER A (10 <sup>2</sup> )	8-3	7-3	10-2-3-12
	T.I.A/B (10 <sup>2</sup> )	8-4	7-NC	10-3-4-12
	T.I.A/B (10 <sup>5</sup> )	8-5	7-4-5	10-4-5-12
RATIO	10 <sup>5</sup>	8-6	7-4	10-5-6
	10 <sup>4</sup>	8-7	7-6	10-6
COUNT A		8-NC	7-6-8	10-7
FREQ A	100Hz	8-9	7-9	10-7-8-9
	10Hz	8-10	7-NC	10-7-8-9
	1Hz	8-11	7-10-11	10-7-8-11
	0.1Hz	8-12	7-10	10-8-11

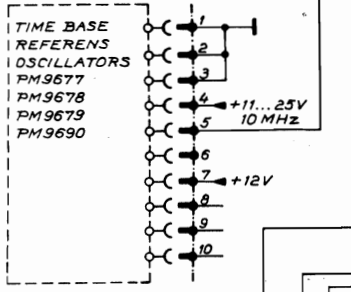

PART OF UNIT 4 TO PM622,24,25

PART OF UNIT 4 TO PM622

PART OF UNI

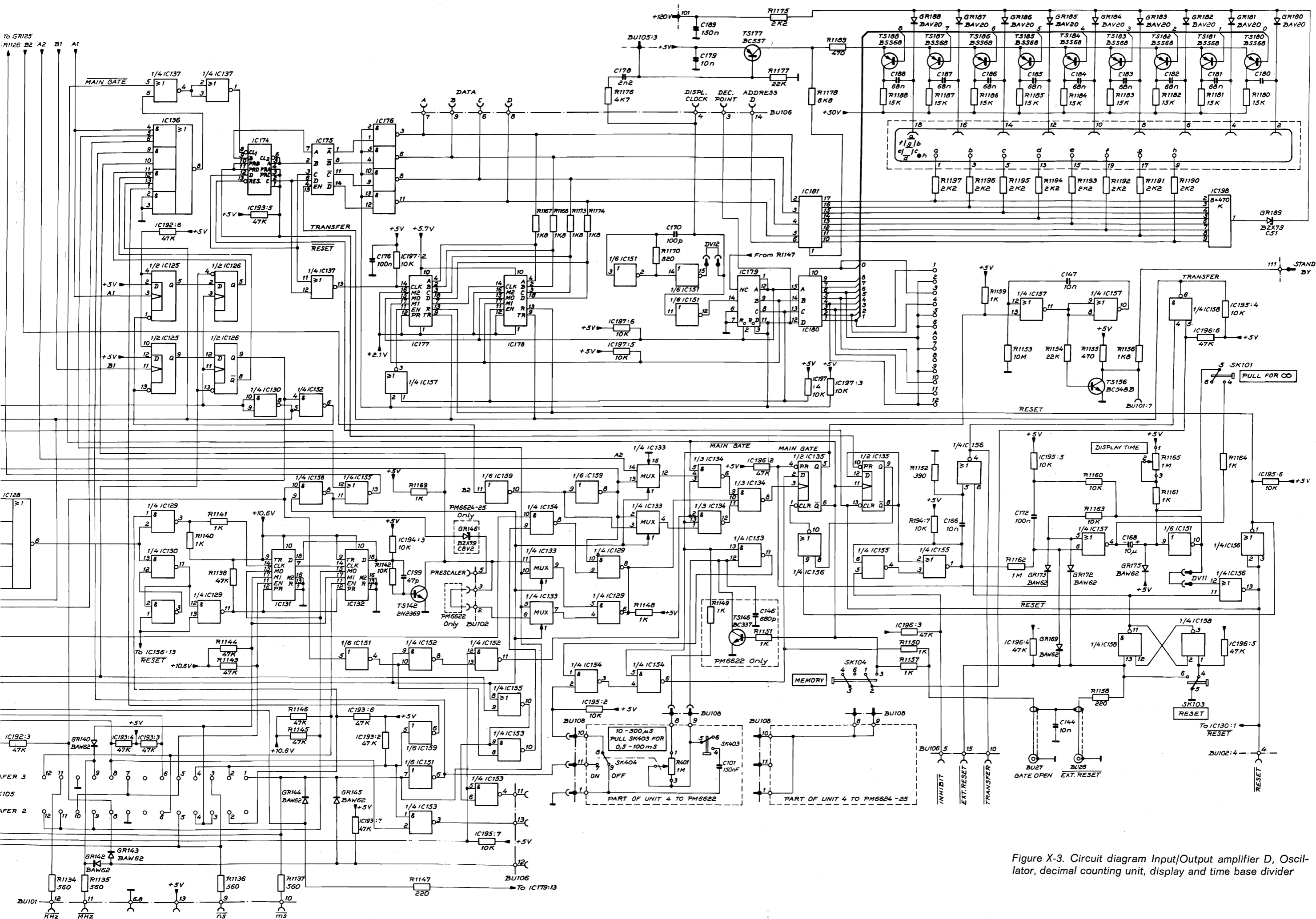

Figure X-3. Circuit diagram Input/Output amplifier D, Oscillator, decimal counting unit, display and time base divider

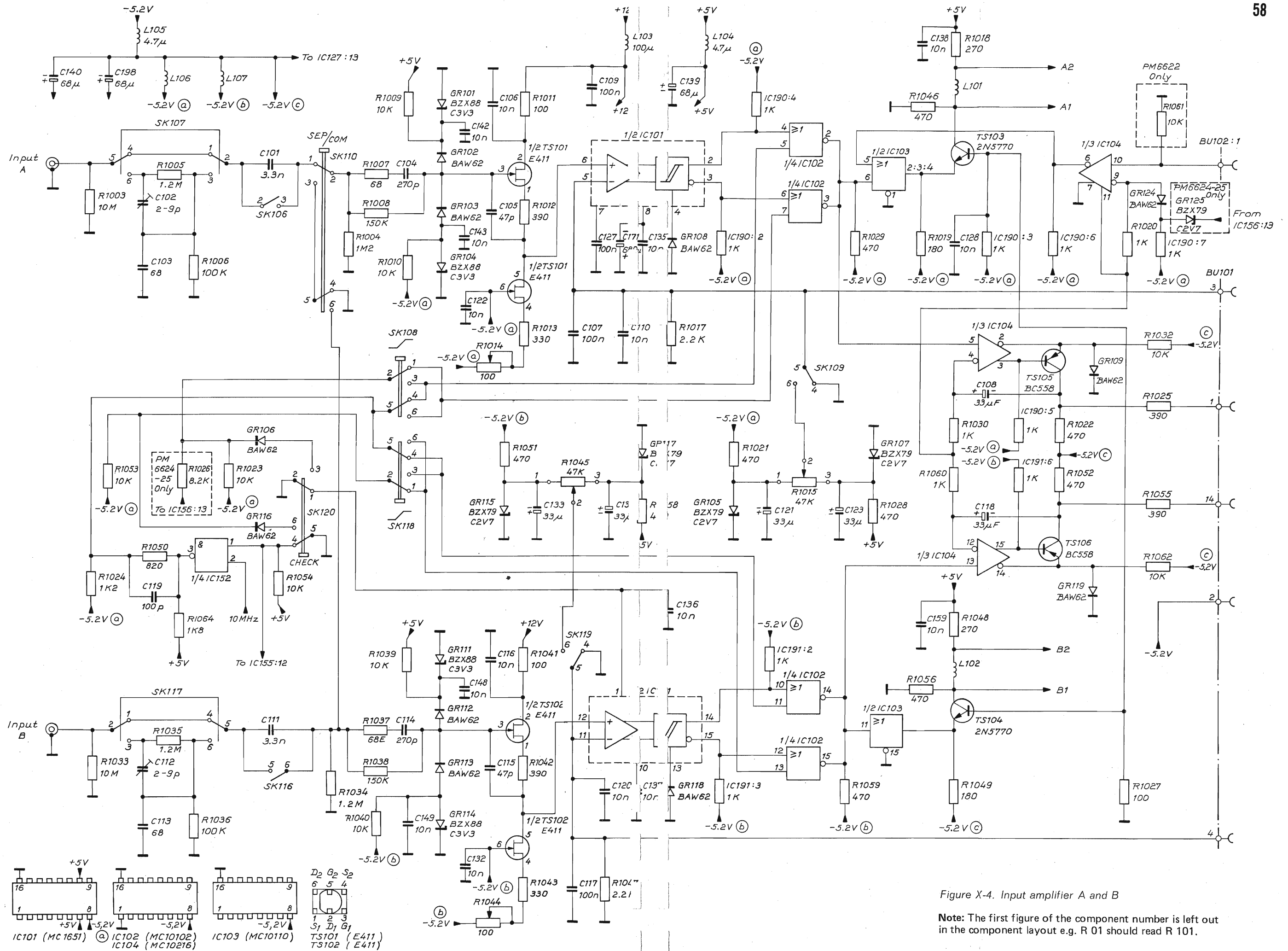

Figure X-4. Input amplifier A and B

Note: The first figure of the component number is left out in the component layout e.g. R 01 should read R 101.

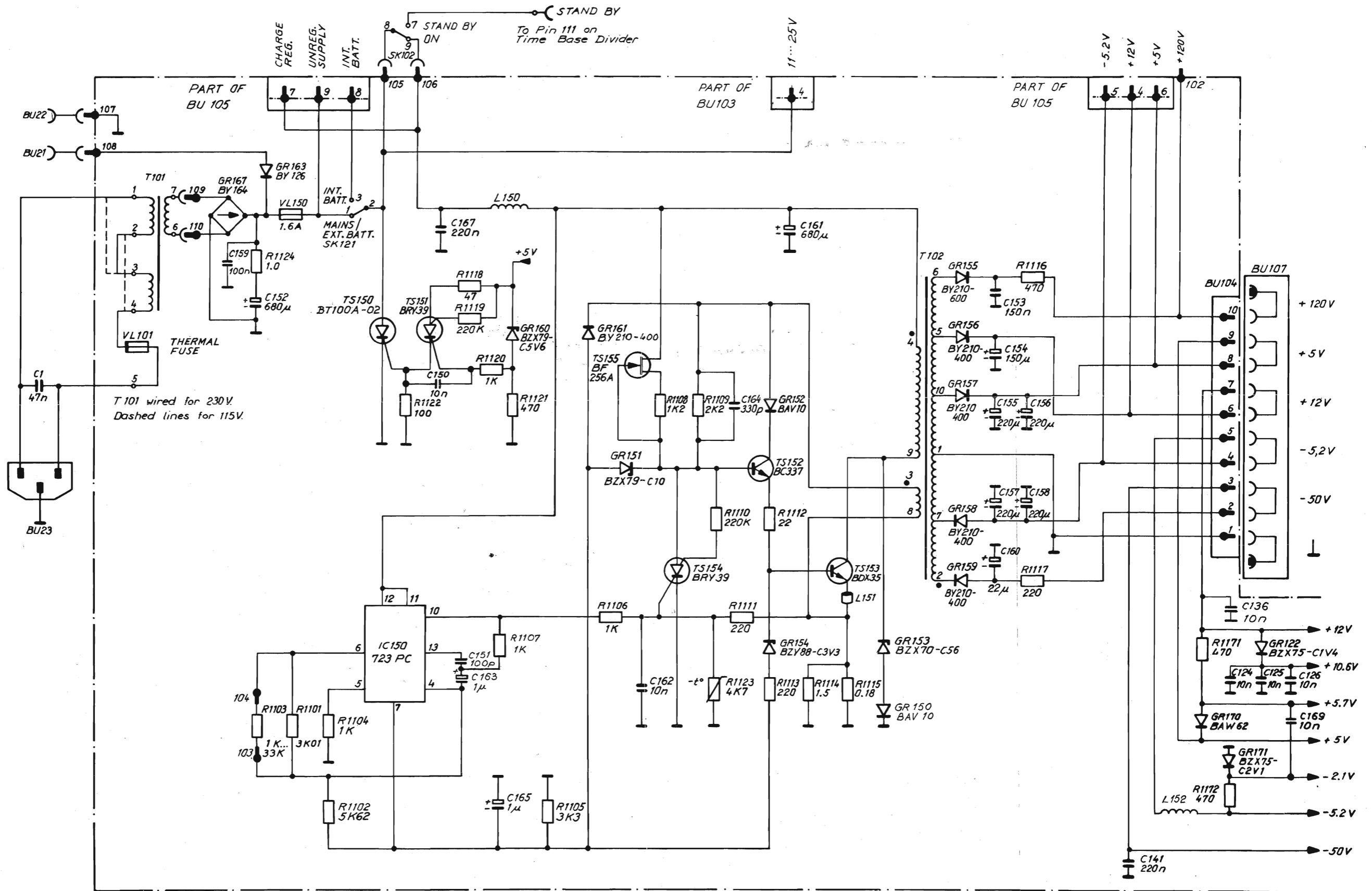

Figure X-5. Power supply

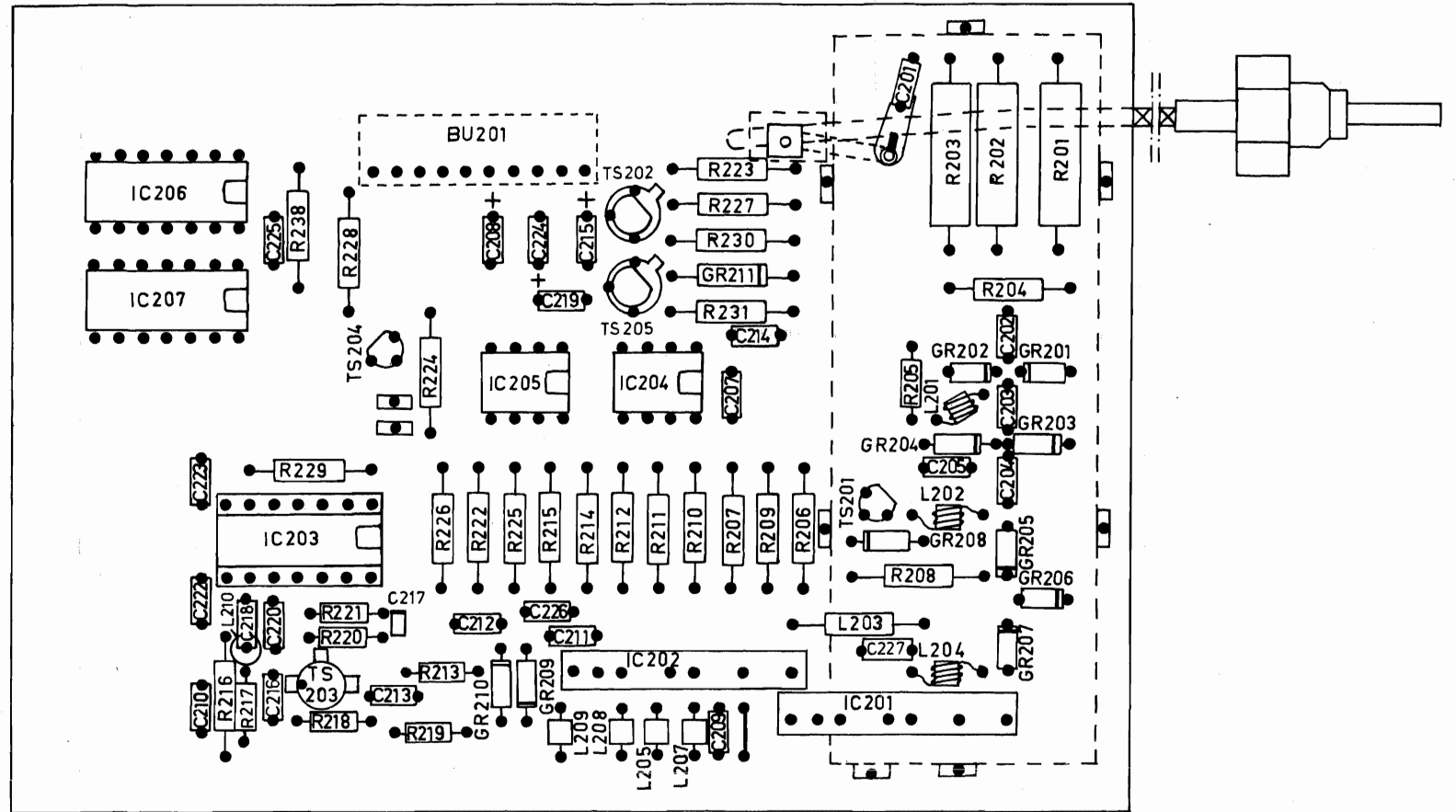

Figure X-6. Component layout prescaler PM 6624, Component side

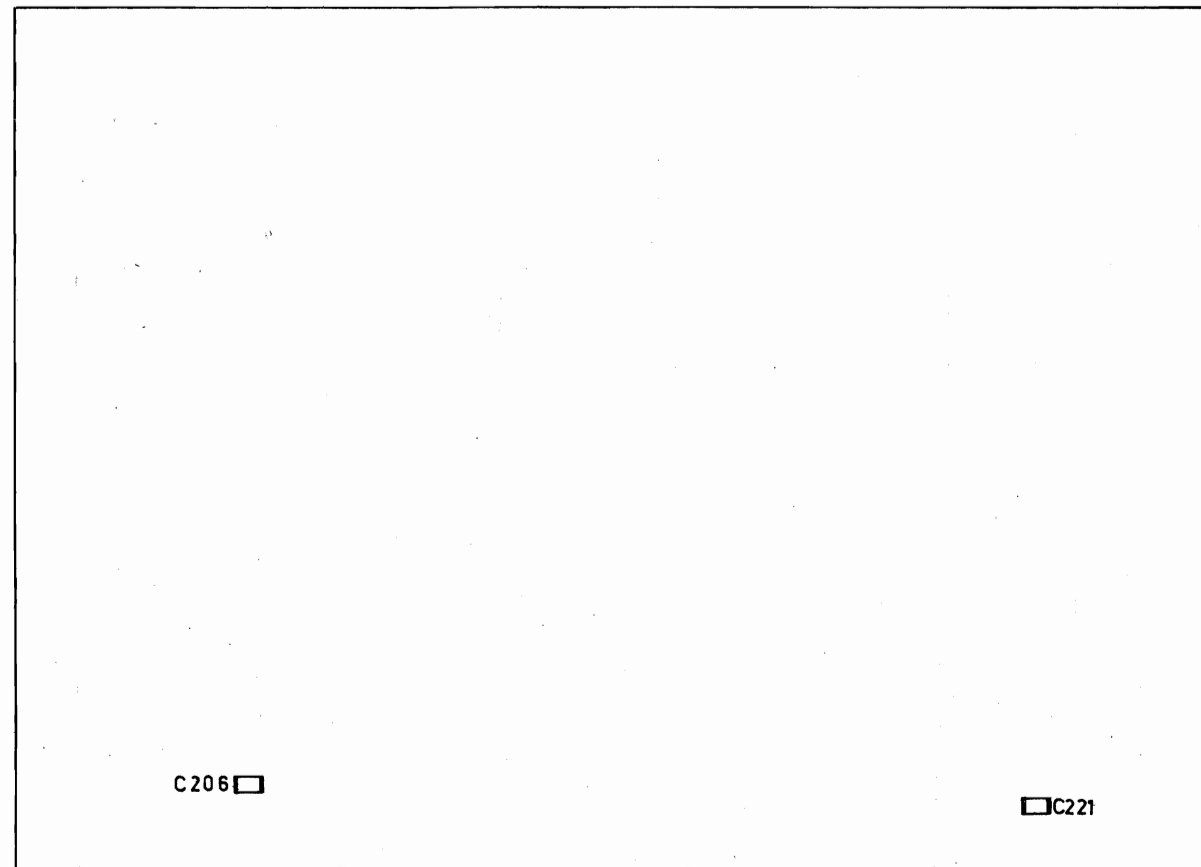
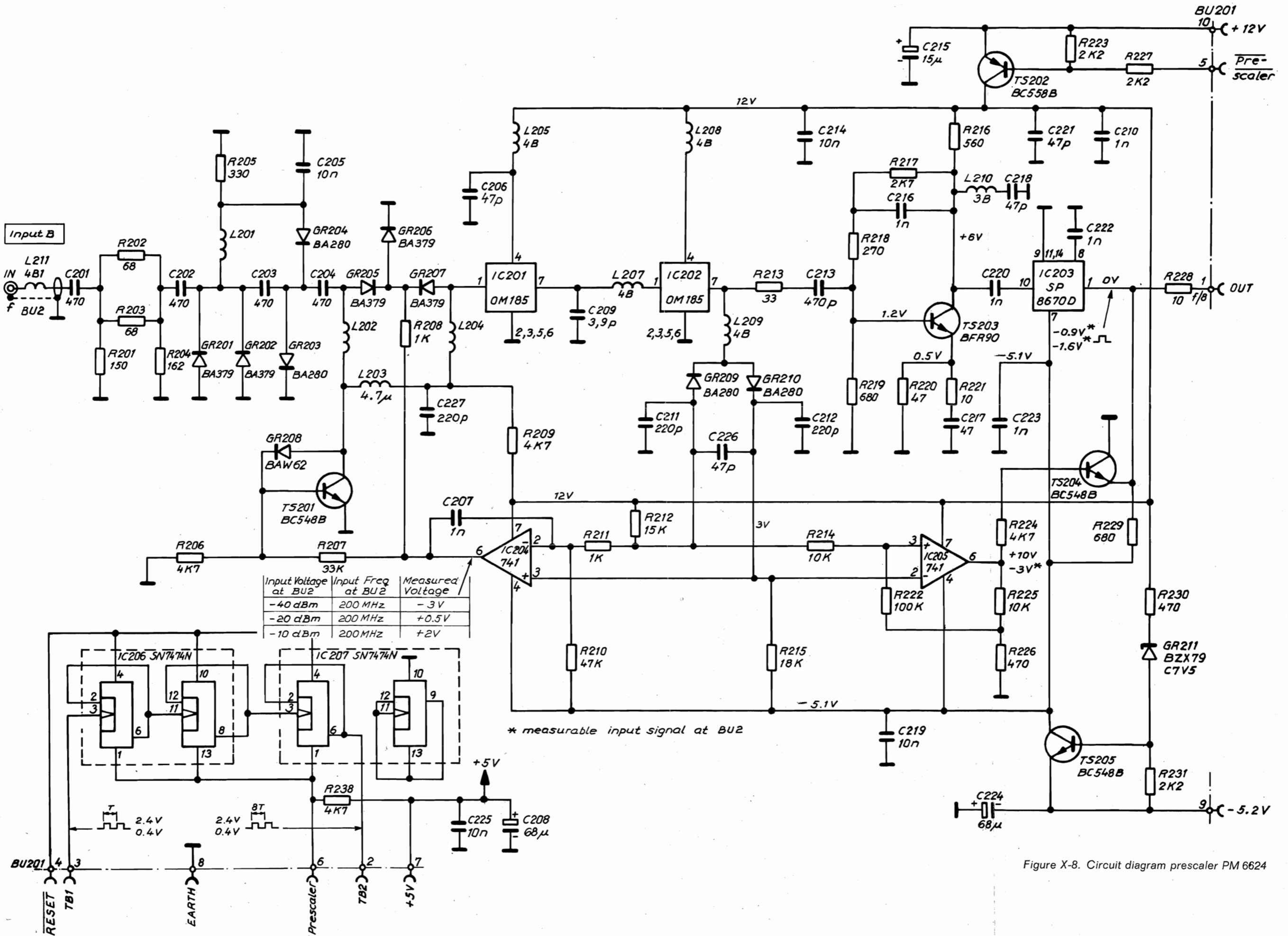

Figure X-7. Component layout prescaler PM 6624, Soldering side





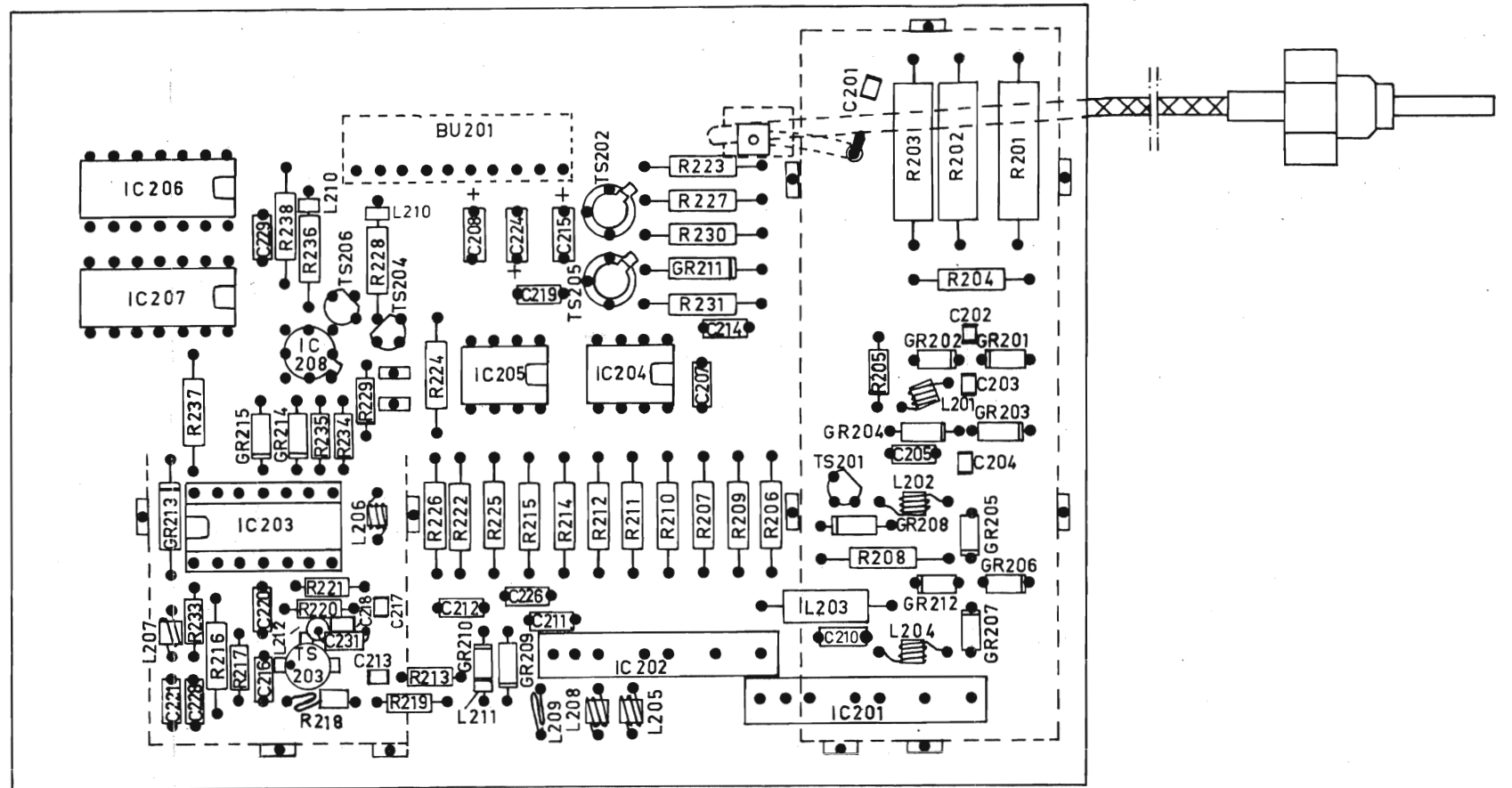

Figure X-9. Component layout prescaler PM 6625, Component side

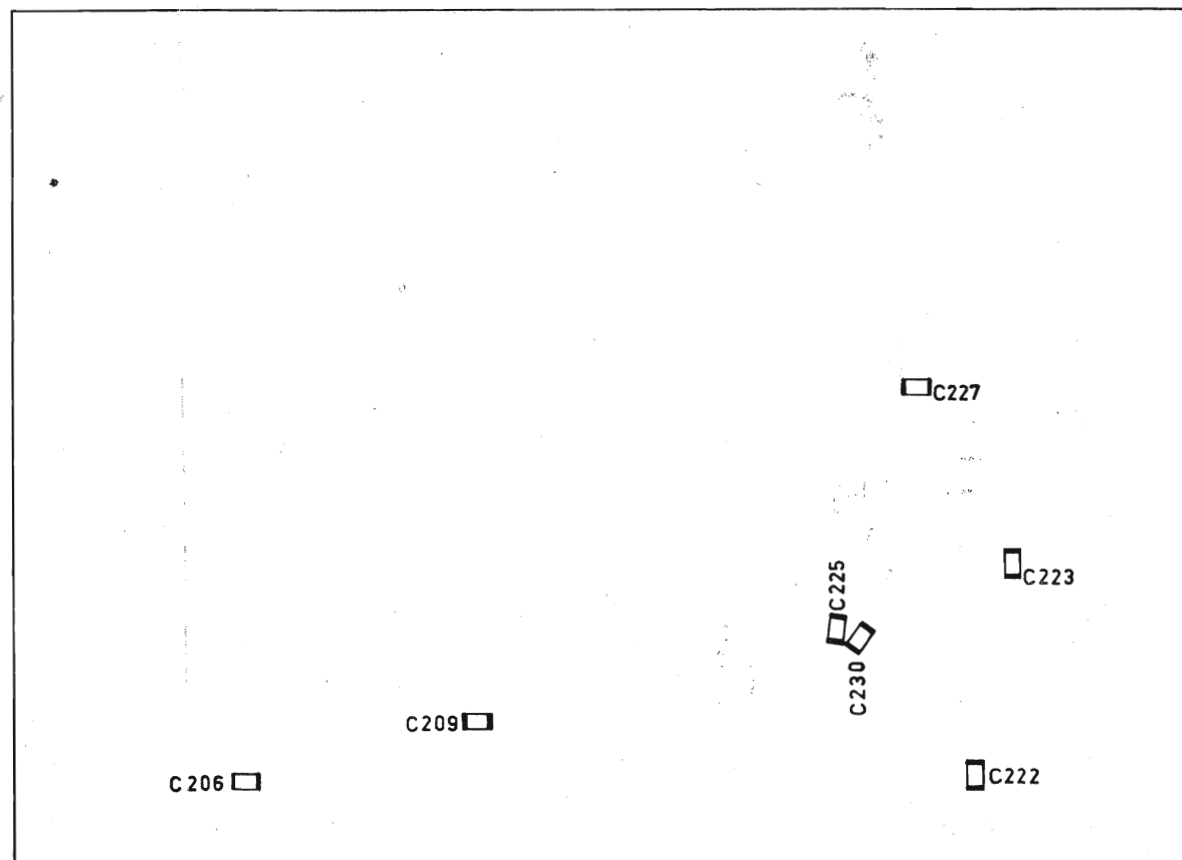

Figure X-10. Component layout prescaler PM 6625, Soldering side

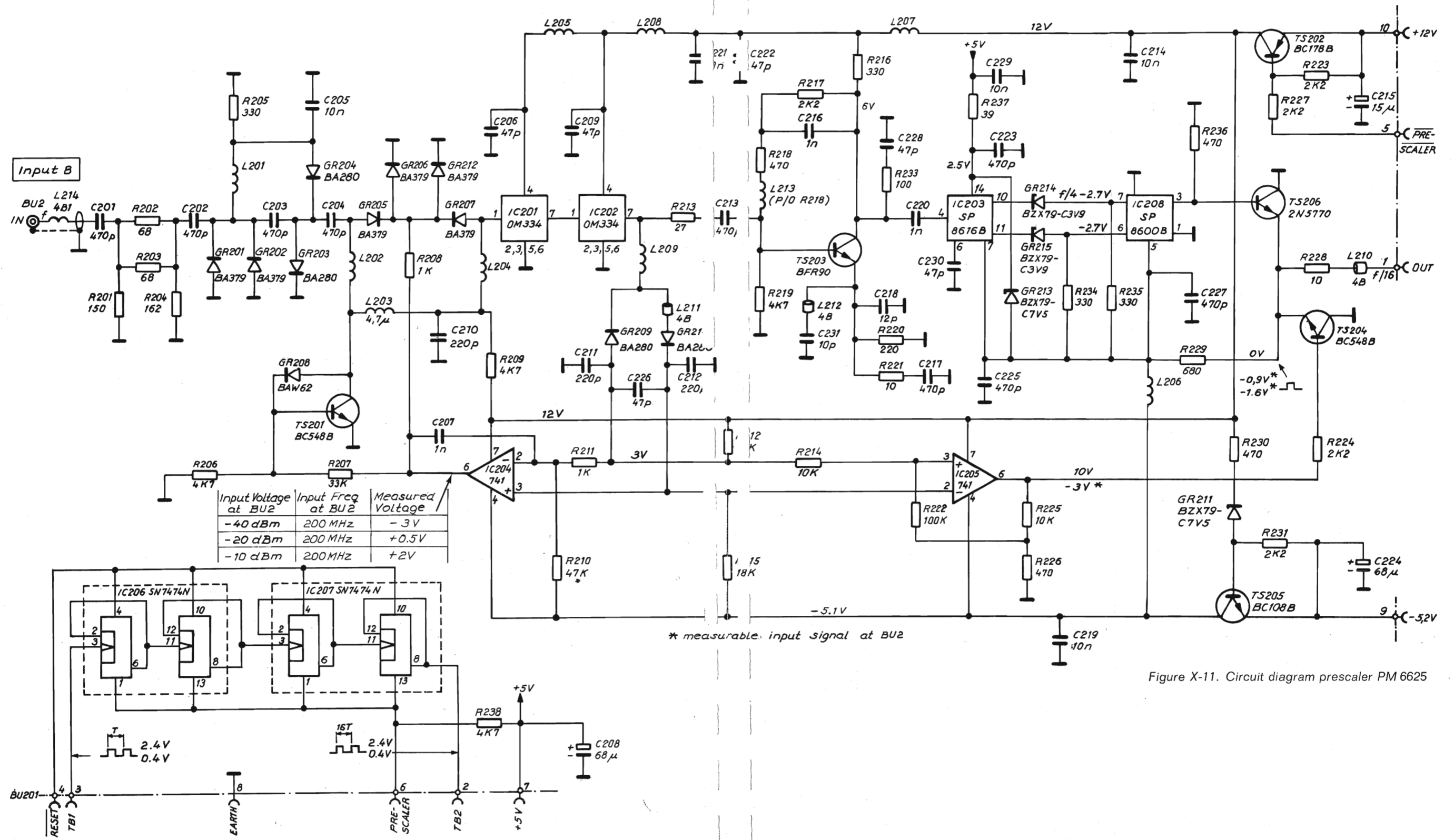

Figure X-11. Circuit diagram prescaler PM 6625

## QUALITY REPORTING

## CODING SYSTEM FOR FAILURE DESCRIPTION

The following information is meant for Philips service workshops only and serves as a guide for exact reporting of service repairs and maintenance routines on the workshop charts.

For full details reference is made to Information G1 (Introduction) and Information Cd 689 (Specific information for Test and Measuring Instruments).

## LOCATION

Unit number

e.g. 000A or 0001 (for unit A or 1; not 00UA or 00U1)

or: Type number of an accessory (only if delivered with the equipment)

e.g. 9051 or 9532 (for PM 9051 or PM 9532)

or: Unknown/Not applicable  
0000

## COMPONENT/SEQUENCE NUMBER

Enter the identification as used in the circuit diagram, e.g.:

GR1003	Diode GR1003
TS0023	Transistor TS23
IC0101	Integrated circuit IC101
R0....	Resistor, potentiometer
C0....	Capacitor, variable capacitor
B0....	Tube, valve
LA....	Lamp
VL....	Fuse
SK....	Switch
BU....	Connector, socket, terminal
T0....	Transformer
LO....	Coil
X0....	Crystal
CB....	Circuit block
RE....	Relay
BA....	Battery
TR....	Chopper

## CATEGORY

0 Unknown, not applicable (fault not present, intermittent or disappeared)

1 Software error

2 Readjustment

3 Electrical repair (wiring, solder joint, etc.)

4 Mechanical repair (polishing, filing, remachining, etc.)

5 Replacement

6 Cleaning and/or lubrication

7 Operator error

8 Missing items (on pre-sale test)

9 Environmental requirements are not met

Parts not identified in the circuit diagram:

990000 Unknown/Not applicable

990001 Cabinet or rack (text plate, emblem, grip, rail, graticule, etc.)

990002 Knob (incl. dial knob, cap, etc.)

990003 Probe (only if attached to instrument)

990004 Leads and associated plugs

990005 Holder (valve, transistor, fuse, board, etc.)

990006 Complete unit (p.w. board, h.t. unit, etc.)

990007 Accessory (only those without type number)

990008 Documentation (manual, supplement, etc.)

990009 Foreign object

990099 Miscellaneous

## Sales and service all over the world

**Alger:** Sadel, 41 Rue des Frères Mouloud Alger; tel. 656613-656607

**Argentina:** Philips Argentina S.A., Cassila Correo 3479, Buenos Aires; tel. T.E. 70, 7741 al 7749

**Australia:** Philips Electrical Pty Ltd., Philips House, 69-79 Clarence Street, Box 2703 G.P.O., Sydney; tel. 2.0223

**België/Belgique:** M.B.L.E, Philips Bedrijfs-apparatuur, 80 Rue des Deux Gares, Bruxelles; tel. 02/13.76.00

**Bolivia:** Industrias Bolivianas Philips S.A. LA Jón postal 2964 La Paz tel. 50029

**Brasil:** S.A. Philips Do Brasil; Avenida Paulista 2163; P.O. Box 8681; Sao Paulo S.P.; tel. 81-2161.

**Burundi:** Philips S.A.R.L., Avenue de Grèce, B.P. 900, Bujumbura

**Canada:** Philips Electronic Industries Ltd., Scientific and Electronic Equipment Division, Philips House, 116 Vanderhoof Avenue, Toronto 17 M 4G 2 J1. tel. (416)-425-5161.

**Chile:** Philips Chilena S.A., Casilla 2687, Santiago de Chile; tel. 94001

**Colombia:** Industrias Philips de Colombia S.A., Calle 13 no. 51-03, Apartado Nacional 1505, Bogota; tel. 473640

**Costa Rica:** Philips de Costa Rica Ltd., Apartado Postal 4325, San José; tel. 210111

**Danmark:** Philips Elektronik Systemer A/S Afd. Industri & Forskning; Strandlodsvej 4 2300-København S; Tel (0127) AS 2222; telex 27045

**Deutschland (Bundesrepublik):** Philips Elektronik Industrie GmbH, 2000 Hamburg 73, Meiendorferstraße 205; Postfach 730 370; tel. 6797-1

**Ecuador:** Philips Ecuador S.A., Casilla 343, Quito; tel. 239080

**Egypt:** Ph. Scientific Bureau 5 Sherif Str. Cairo - A.R. Egypt P.O. Box 1807; tel. 78457-57739

**Eire:** Philips Electrical (Ireland) Ltd., Newstead, Clonskeagh, Dublin 14; tel. 976611

**El Salvador:** Philips de El Salvador, Apartado Postal 865, San Salvador; tel. 217441

**España:** Philips Ibérica S.A.E., Avenida de America, Apartado 2065, Madrid 17; tel. 2462200

**Ethiopia:** Philips Ethiopia (Priv. Ltd. Co.), P.O.B. 2565; Cunningham Street, Addis Abeba; tel. 48300

**Finland:** Oy Philips Ab, Postboks 10255, Helsinki 10; tel. 10915

**France:** Philips Industrie, Division de ia S.A. Philips Industrielle et Commerciale 105 Rue de Paris, 93 002 Bobigny; tel. 830-11-11

**Ghana:** Philips (Ghana) Ltd., P.O.B. M 14, Accra; tel. 66019

**Great Britain:** Pye Unicam Ltd., York Street, Cambridge; tel. (0223) 58866

**Guatemala:** Philips de Guatemala S.A., Apartado Postal 238, Guatemala City; tel. 64857

**Hellas:** Philips S.A. Hellénique, 54, Ave Syngrou, Athens; tel. 230476, P.O. Box 153

**Honduras:** Hasbun de Honduras Apartado Postal 83, Tegucigalpa; tel. 2-9121...5

**Hong kong:** Philips Hong Kong Ltd., P.O.B. 2108, St. George's Building, 21st floor, Hong Kong; tel. 5-249246

**India:** Philips India Ltd., Shivsagar Estate, Block "A", Dr. Annie Besant Road, P.O.B. 6598, Worli, Bombay 18; tel. 370071

**Indonesia:** P. T. Philips Development Corporation, Jalan Proklamasi 33, P.O.B. 2287, Jakarta; tel. 51985-51986

**Iran:** Philips Iran Ltd., P.O.B. 1297, Teheran; tel. 662281

**Iraq:** Philips Iraq W.L.L. Munir Abbas Building 4th Floor; South Gate. P.O. box 5749 Baghdad; tel. 80409

**Island:** Heimilistaeki SF, Saetún 8, Reykjavik; tel. 24000

**Islas Canarias:** Philips Ibérica S.A.E., Triana 132, Las Palmas; Casilla 39-41, Santa Cruz de Tenerife

**Italia:** Philips S.p.A., Sezione PIT; Viale Elvezia 2, 20052 Monza; tel. (039) 361-441; telex 35290

**Kenya:** Philips (Kenya) Ltd., P.O.B. 30554, Nairobi; tel. 29981

**Malaysia:** Philips Malaya Sdn Bhd. P.O. Box 332, Kuala Lumpur; Selangor W. Malaysia; tel. 774411

**Mexico:** Philips Comercial S.A. de C.V., Uruapan 7, Apdo 24-328. Mexico 7 D.F.; tel. 25-15-40

**Nederland:** Philips Nederland B.V., Boschdijk, Gebouw VB, Eindhoven; tel. 793333

**Ned. Antillen:** N.V. Philips Antillana, Postbus 523, Willemstad; tel. Curaçao 36222-35464

**New Zealand:** Philips Electronical Industries (N.Z.) Ltd., Professional and Industrial Division, 70-72 Kingsford Smith Street, P.O.B. 2097, Lyall Bay, Wellington; tel. 73-156

**Nigeria:** Philips (Nigeria) Ltd., 6 Ijora Causeway, P.O.B. 1921, Lagos; tel. 45414/7

**Nippon:** Nihon Philips Corporation, P.O.B. 13, World Trade Center, 32<sup>nd</sup> Floor, Tokyo 105; tel. (03) 435-5211

**Norge:** Norsk A.S. Philips, Postboks 5040, Oslo; tel. 463890

**Österreich:** Oesterreichische Philips Industrie GmbH, Abteilung Industrie Elektronik, Triesterstrasse 64, A-1101 Wien; tel. (0222) 645511/31

**Pakistan:** Philips Electrical Co. of Pakistan Ltd., El-Markaz, M.A. Jinnah Road, P.O.B. 7101, Karachi; tel. 70071

**Paraguay:** Philips del Paraguay S.A., Casilla de Correo 605, Asuncion; tel. 8045-5536-6666

**Perú:** Philips Peruana S.A., Apartado Postal 1841, Lima; tel. 326070

**Philippines:** Philips Industrial Development Inc., 2246 Pasong Tamo P.O.B. 911, Makati

Rizal D-708; tel. 889453 to 889456

**Portugal:** Philips Portuguesa S.A.R.L., Av. Eng.° Duarte Pacheco, 6 - Lisboa - 1

**Rwanda:** Philips Rwanda S.A.R.L., B.P. 449, Kigali

**Saudi Arabia:** A. Rajab and A. Silsilah P.O. box 203 Jeddah - Saudi Arabia; tel. 5113-5114

**Schweiz-Suisse-Svizzera:** Philips A.G., Binzstrasse 15, Postfach 8027, Zürich; tel. 051-442211

**Singapore:** Philips Singapore Private Ltd. P.O. Box 340; Toa Payoh Central Post Office; Singapore 12; tel. 538811

**South Africa:** South African Philips (Pty) Ltd., P.O.B. 7703, 2, Herb Street, New Doornfontein, Johannesburg; tel. 24-0531

**Sverige:** Svenska A.B. Philips, Fack, Liding-övågen 50, Stockholm 27; tel. 08/635000

**Syria:** Philips Moyen-Orient S.A. Rue Fardoss 79 Immeuble Kassas and Sadate B.P. 2442 Damas; tel. 18605-21650

**Taiwan:** Yung Kang Trading Co. Ltd., San Min Building, Gnd Floor, 57-1 Chung Shan N Road, 2 Section, P.O.B. 1467, Taipei; tel. 577281

**Tanzania:** Philips (Tanzania) Ltd., Box 20104, Dar es Salaam; tel. 29571

**Thailand:** Philips Thailand Ltd., 283, Silom Road, Bangkok; tel. 36980, 36984-9

**Turkey:** Türk Philips Ticaret A.S., Posta Kutusu 504, Beyoglu; Gümüssüyük Caddesi 78/80 Istanbul 1 Turkey

**Uganda:** Philips Uganda Ltd. p.o. Box 5300 Kampala; tel. 59039

**Uruguay:** Industrias Philips del Uruguay, Avda Uruguay 1287, Montevideo; tel. 915641 Casilla de Correo 294

**U.S.A.:** Philips Test and Measuring Instruments Inc.; 400 Crossways Park Drive, Woodbury, N.Y. 11797; tel. (516) 921-8880

**Venezuela:** C.A. Philips Venezolana, Apartado Postal 1167, Caracas; tel. 360511

**Zaire:** Philips S.Z.R.L., B.P. 1798, Kinshasa; tel. 31887-31888-31693

**Zambia:** Philips Electrical Ltd., Professional Equipment Division, P.O.B. 553 Kitwe; tel. 2526/7/8; Lusaka P.O. Box 1878

75101

### For information on change of address:

N.V. Philips  
Test and Measuring Instruments Dept.  
Eindhoven - The Netherlands

### For countries not listed:

N.V. Philips PIT Export Dept.  
Test and Measuring Instruments Dept.  
Eindhoven - The Netherlands

Block diagram

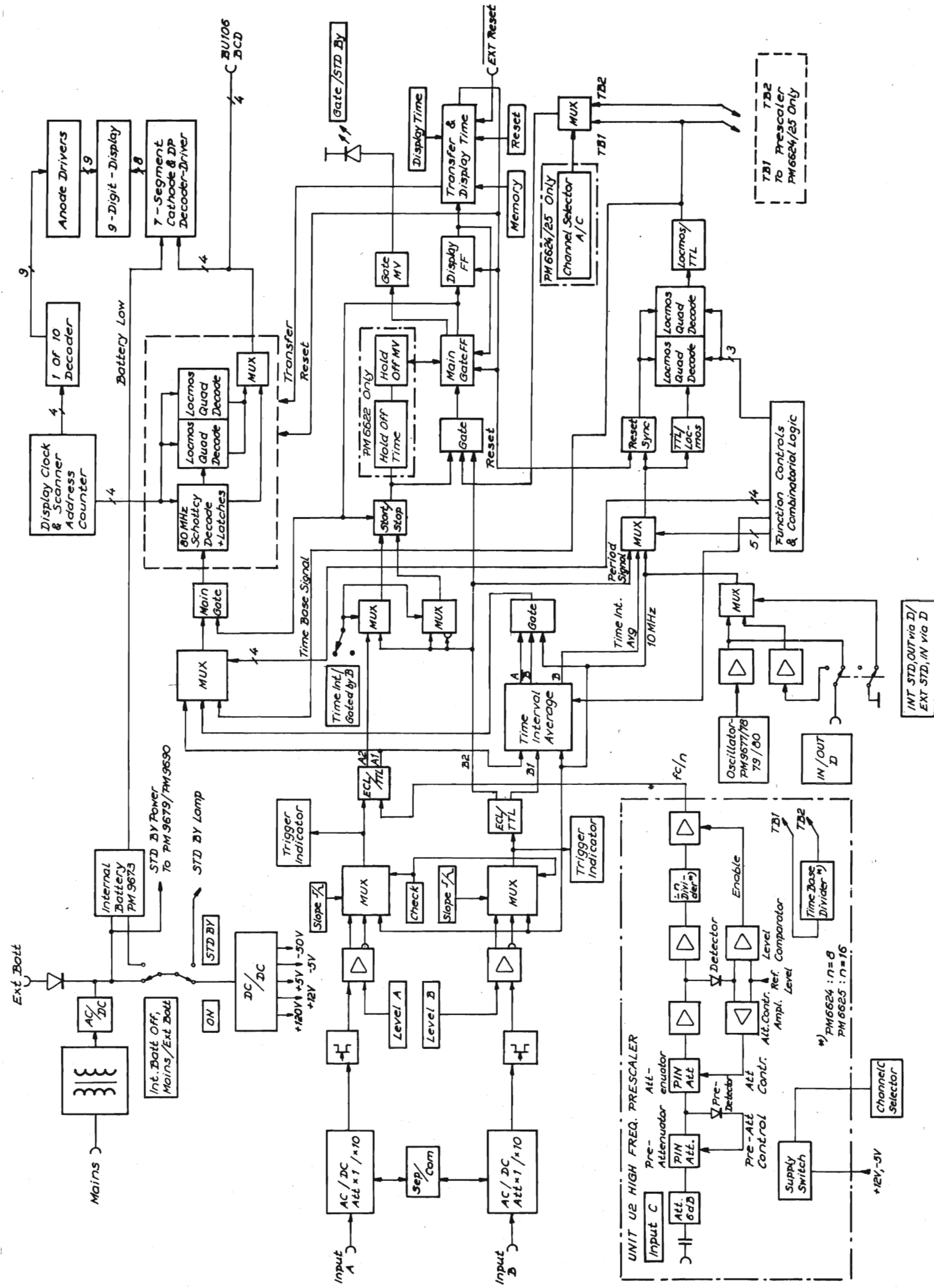

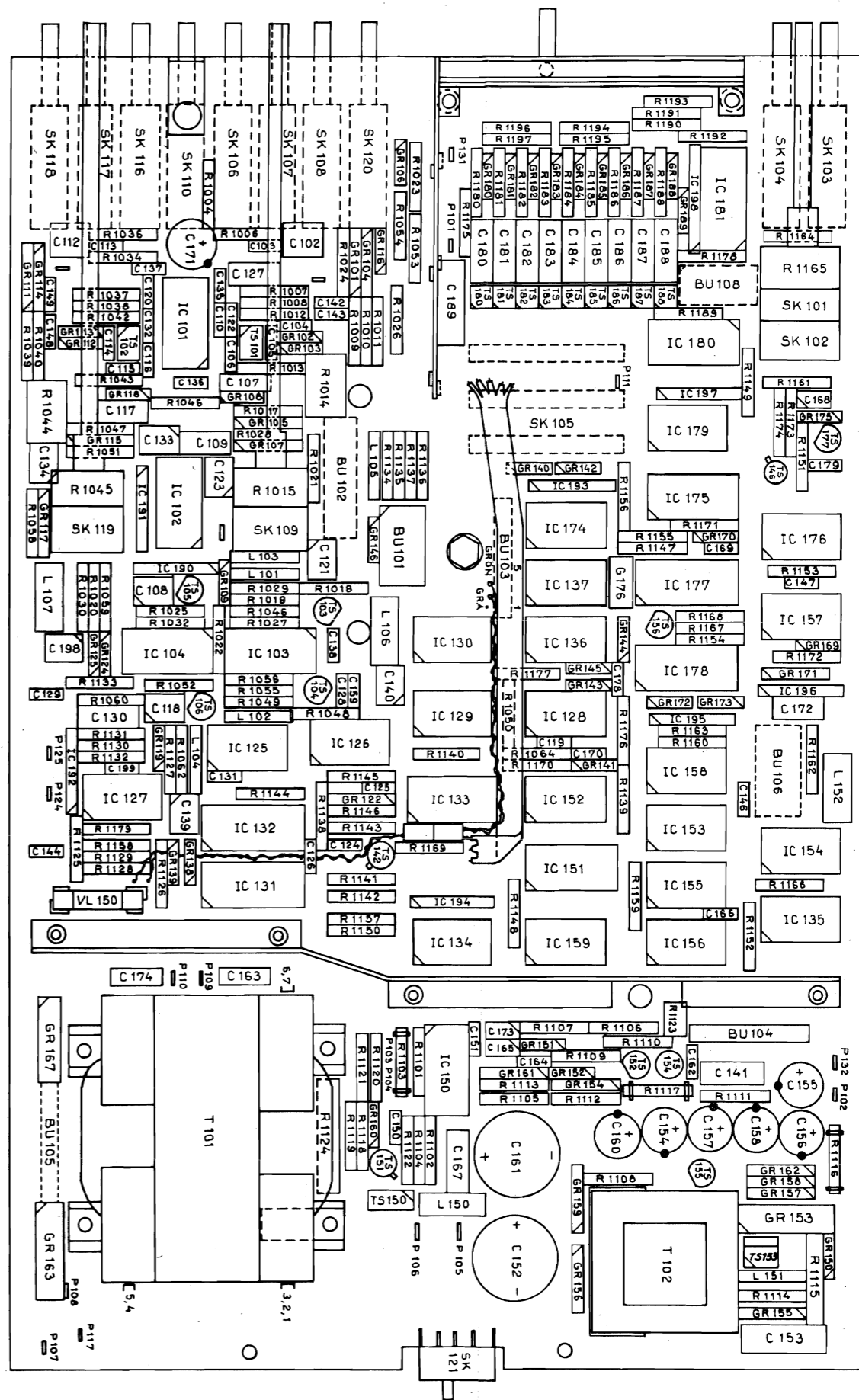
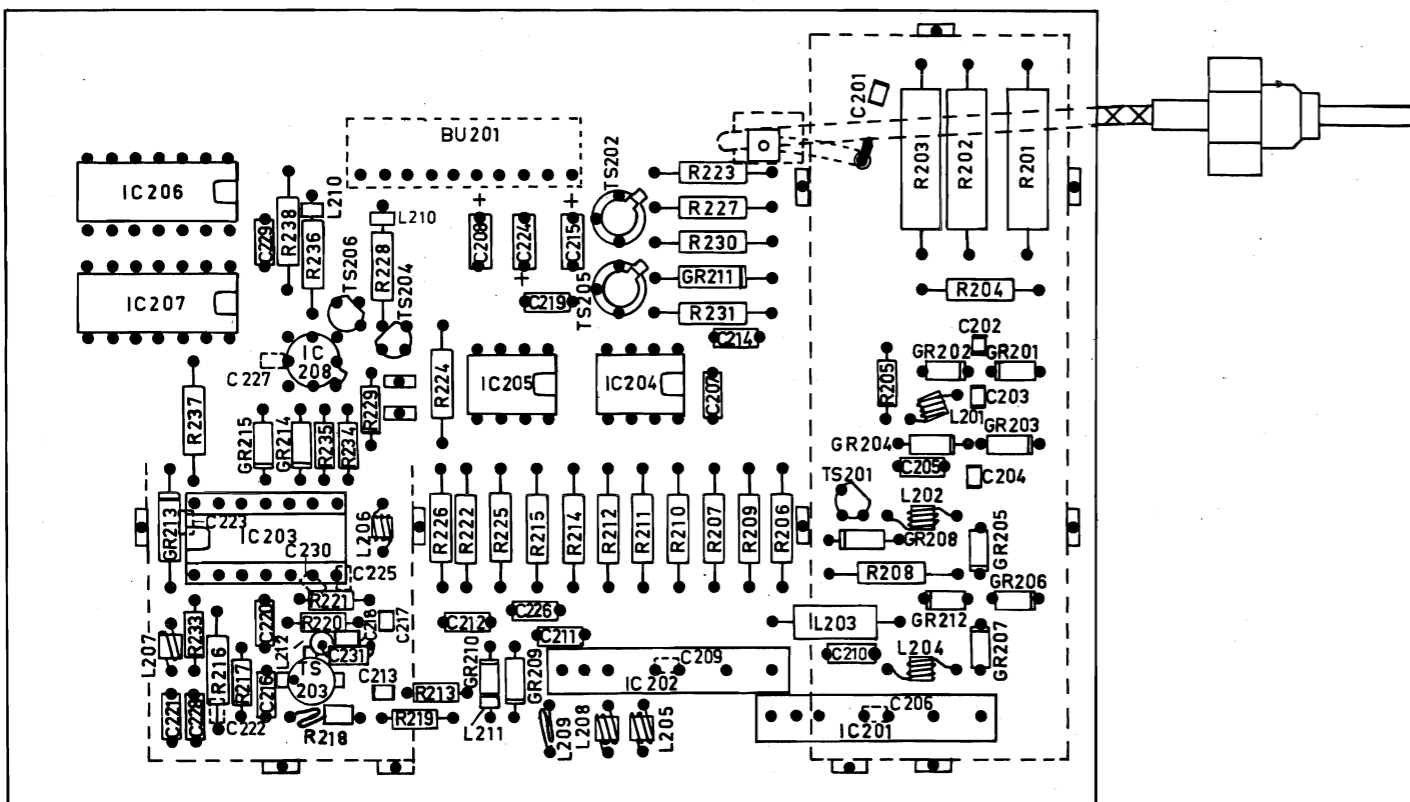
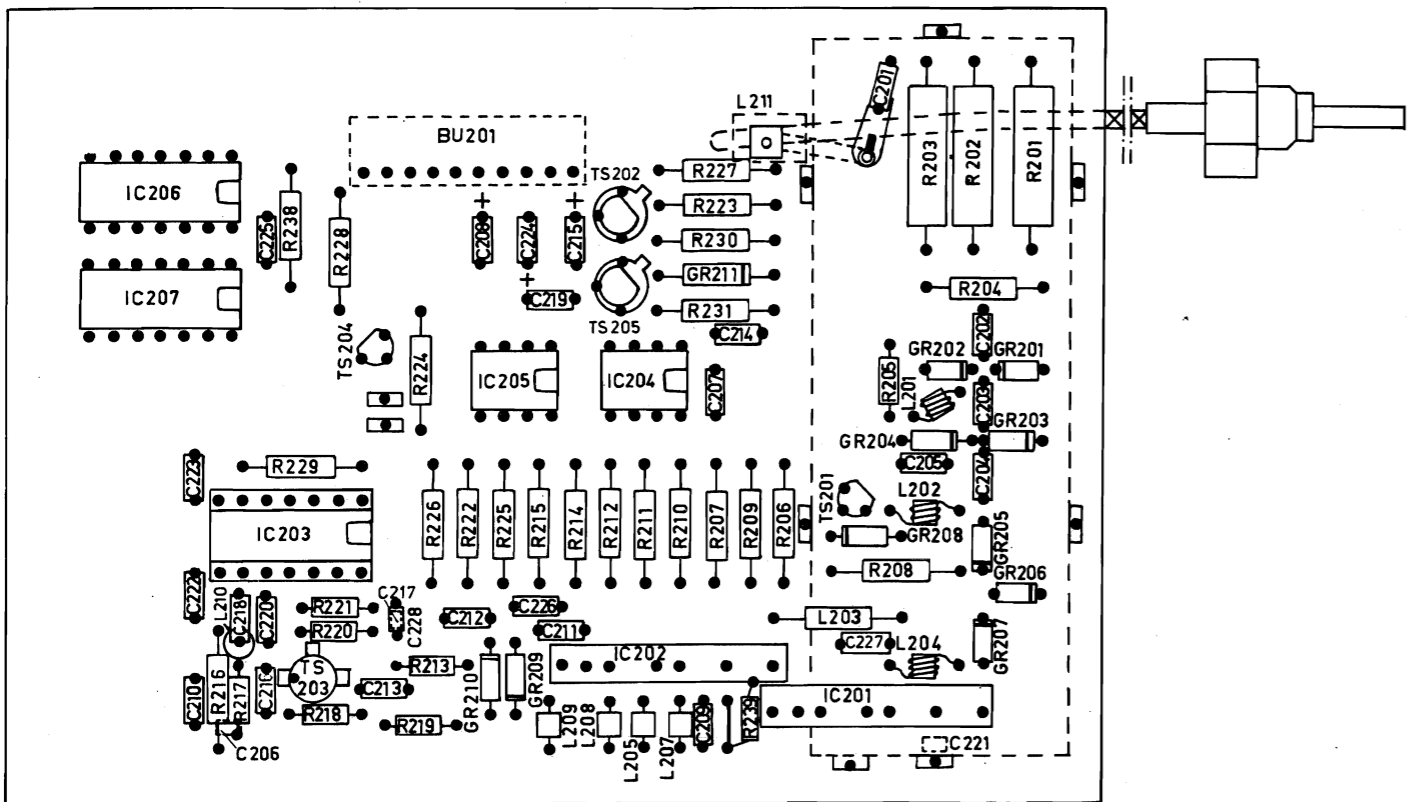

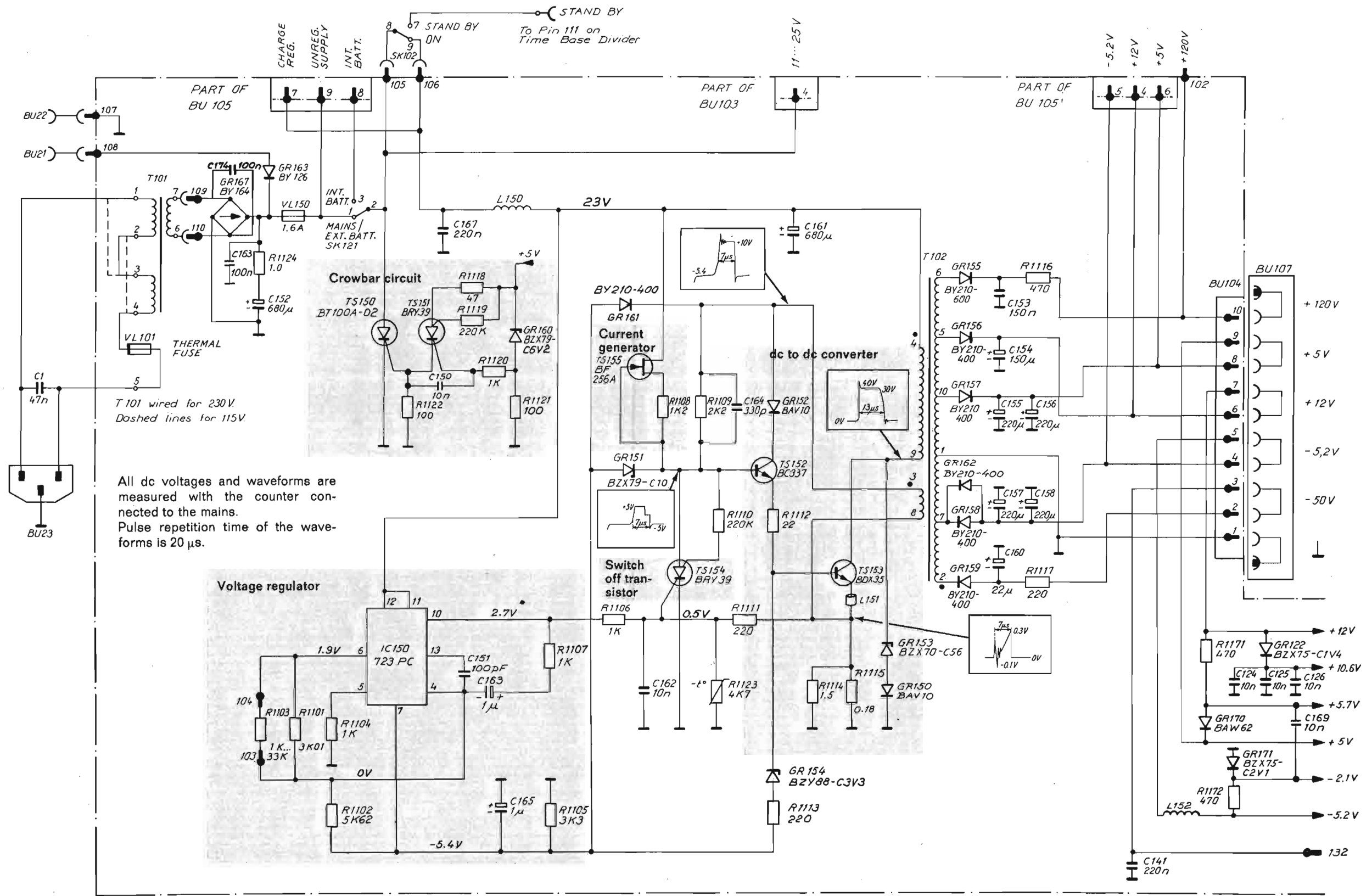

All dc voltages and waveforms are measured with the counter connected to the mains. Pulse repetition time of the waveforms is 20 µs.

Voltage regulator

Crowbar circuit

Current generator

dc to dc converter

Switch off transistor

T101 wired for 230V. Dashed lines for 115V.

BU22

BU21

BU23

BU104

BU107

BU108

BU109

BU110

BU111

BU112

BU113

BU114

BU115

BU116

BU117

BU118

BU119

BU120

BU121

BU122

BU123

BU124

BU125

BU126

BU127

BU128



The waveforms are re-recorded with a 50 MHz 2 channels oscilloscope. The preliminary setting of the counter is minimum display time, Check mode and Frequency A 100 Hz. The rest of the controls is set to neutral position.

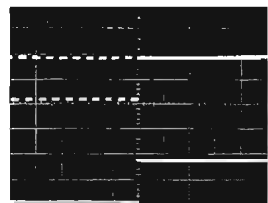

Inputsignal: 1 KHz

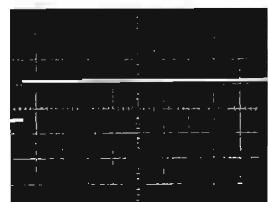

Frequency A 0.1 Hz



Frequency A 10 Hz  
Display: 10.00000



Single Period 0.1 ms  
Hold off is on



Input C



IC 181:17  
0.2 ms/div  
50 V/div

①  
2 ms/div  
2 V/div  
  
IC 134:5  
2 ms/div  
2 V/div

②  
2 μs/div  
5 V/div

③  
0.2 ms/div  
5 V/div

④  
0.2 ms/div  
5 V/div

⑤  
0.5 ms/div  
2 V/div  
  
IC 134:5  
0.5 ms/div  
2 V/div

⑥  
50 μs/div  
2 V/div

⑦  
50 μs/div  
2 V/div

⑧  
0.2 ms/div  
50 V/div  
  
IC 181:17  
0.2 ms/div  
50 V/div

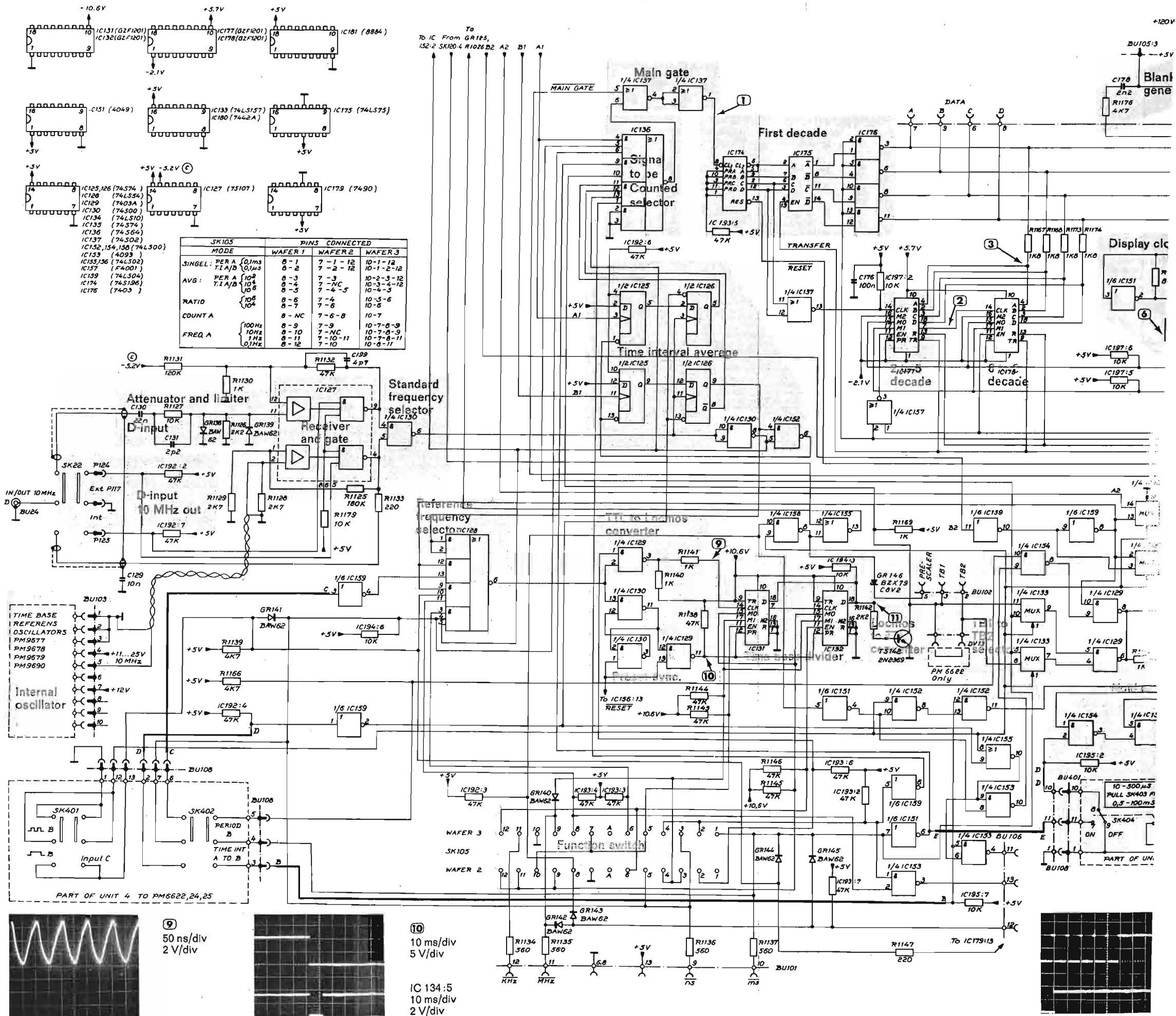

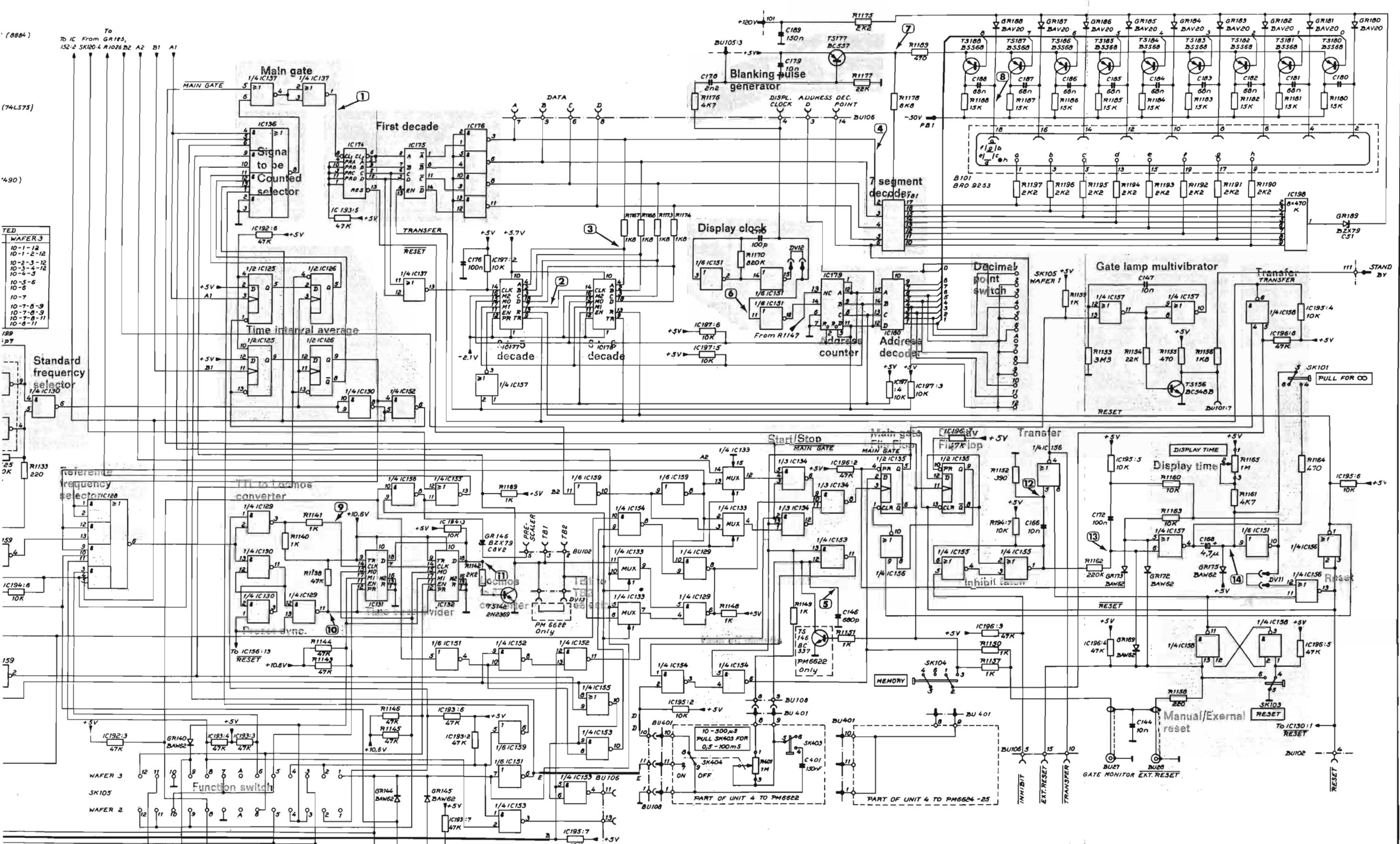

WAFER 3

10-1-12
10-1-2-12
10-2-3-12
10-3-4-12
10-5-6
10-7
10-7-8-9
10-7-8-9
10-7-8-11
10-8-11

Standard frequency selector

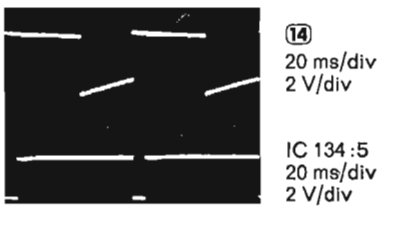
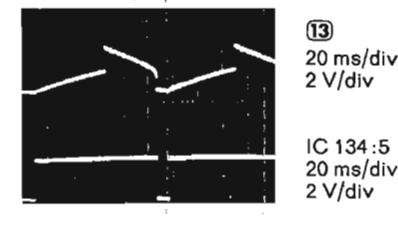
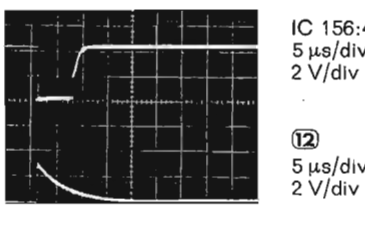
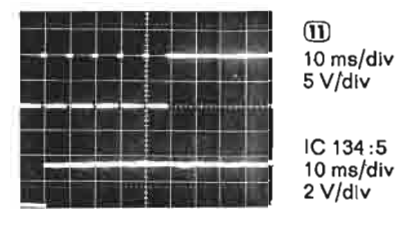
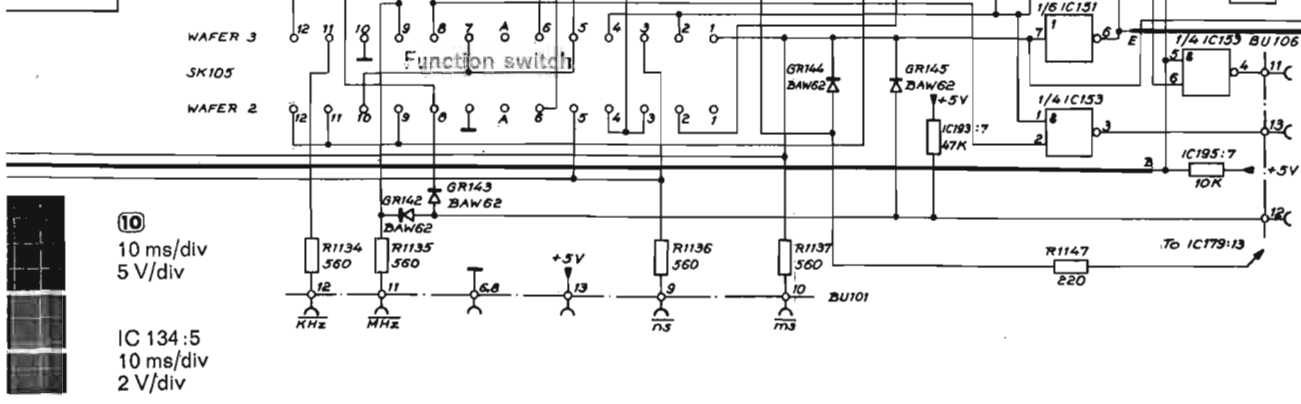
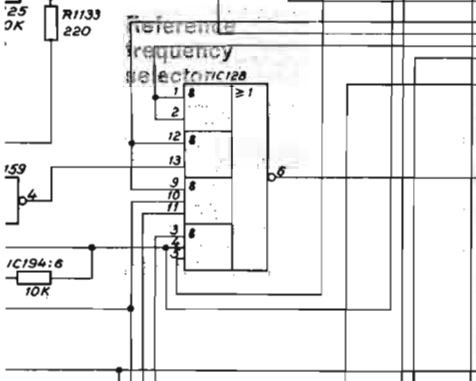





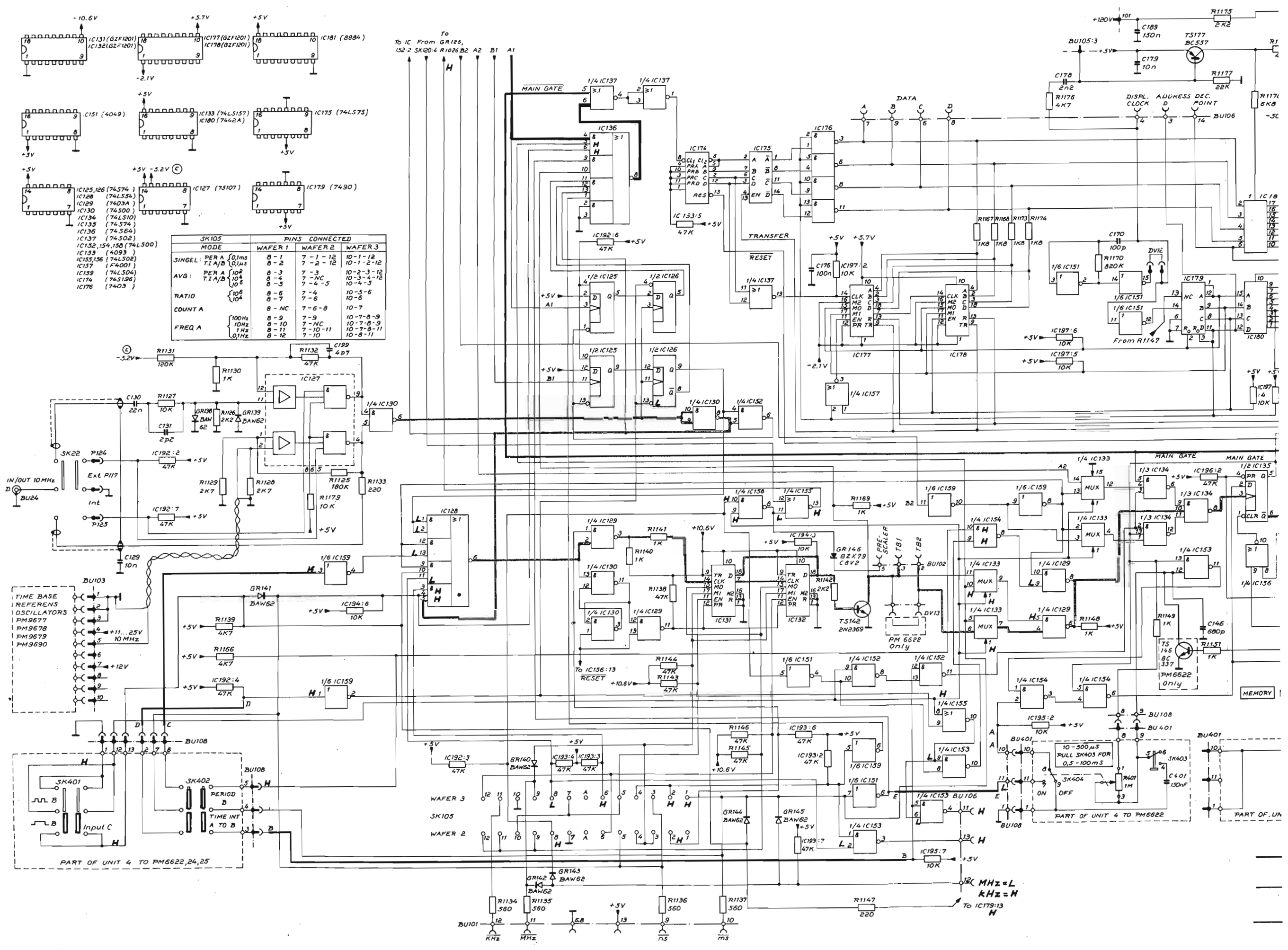

SK105		PINS CONNECTED		
MODE		WAFER 1	WAFER 2	WAFER 3
SINGEL:	PER A	8-1	7-1-12	10-1-12
	T.I.A/B	8-2	7-2-12	10-1-2-12
AVG:	PER A	8-3	7-3	10-2-3-12
	T.I.A/B	8-4	7-NC	10-3-4-12
		8-5	7-4-5	10-4-5
RATIO		8-5	7-4	10-5-6
		8-7	7-6	10-6
COUNT A		8-NC	7-6-8	10-7
FREQ A	100Hz	8-9	7-9	10-7-8-9
	10Hz	8-10	7-NC	10-7-8-9
	0.1Hz	8-11	7-10-11	10-7-8-11
		8-12	7-10	10-8-11

- TIME BASE REFERENCE OSCILLATORS
- PM9677
  - PM9678
  - PM9679
  - PM9690

PART OF UNIT 4 TO PM6622, 24, 25

10-500 μS PULL SK403 FOR 0.5-100MS

PART OF UNIT 4 TO PM6622

PART OF UNIT 4 TO PM6622

12C MHz=L  
kHz=H  
H

To IC175:13



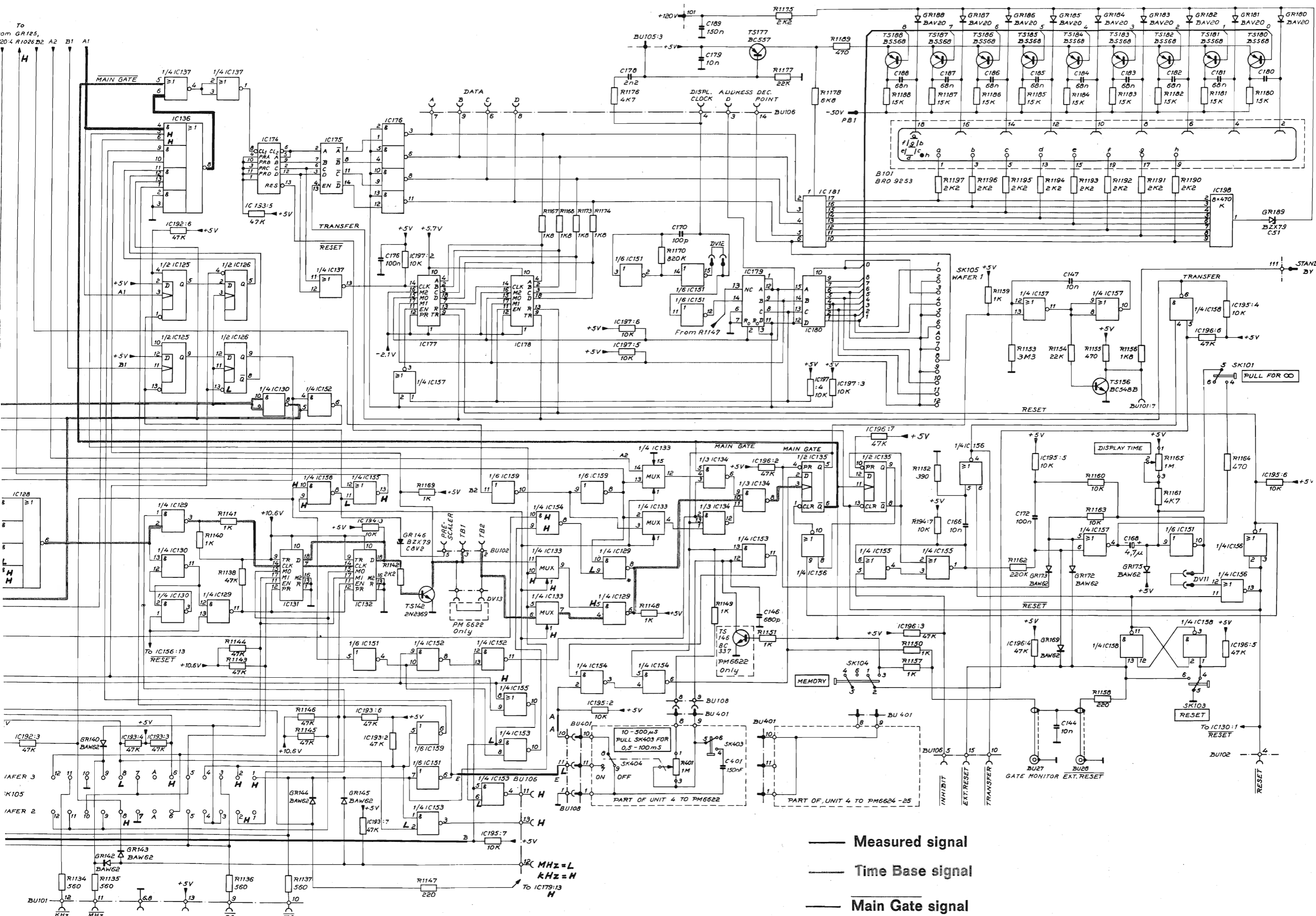

— Measured signal  
 - - - Time Base signal  
 . . . Main Gate signal

32 MHz = L  
 kHz = H  
 To IC178:13 H

10-500 μs  
 PULL SK403 FOR  
 0.5-100ms

PART OF UNIT 4 TO PM6622  
 PART OF UNIT 4 TO PM6624-25

GATE MONITOR EXT. RESET

To IC130:1  
 RESET

BU102  
 RESET

SK103  
 RESET

RESET

RESET

RESET

RESET

RESET

RESET

RESET

RESET

RESET

RESET

RESET

RESET

RESET

RESET

RESET

RESET

RESET

RESET

RESET

RESET

RESET

RESET

RESET

RESET

RESET

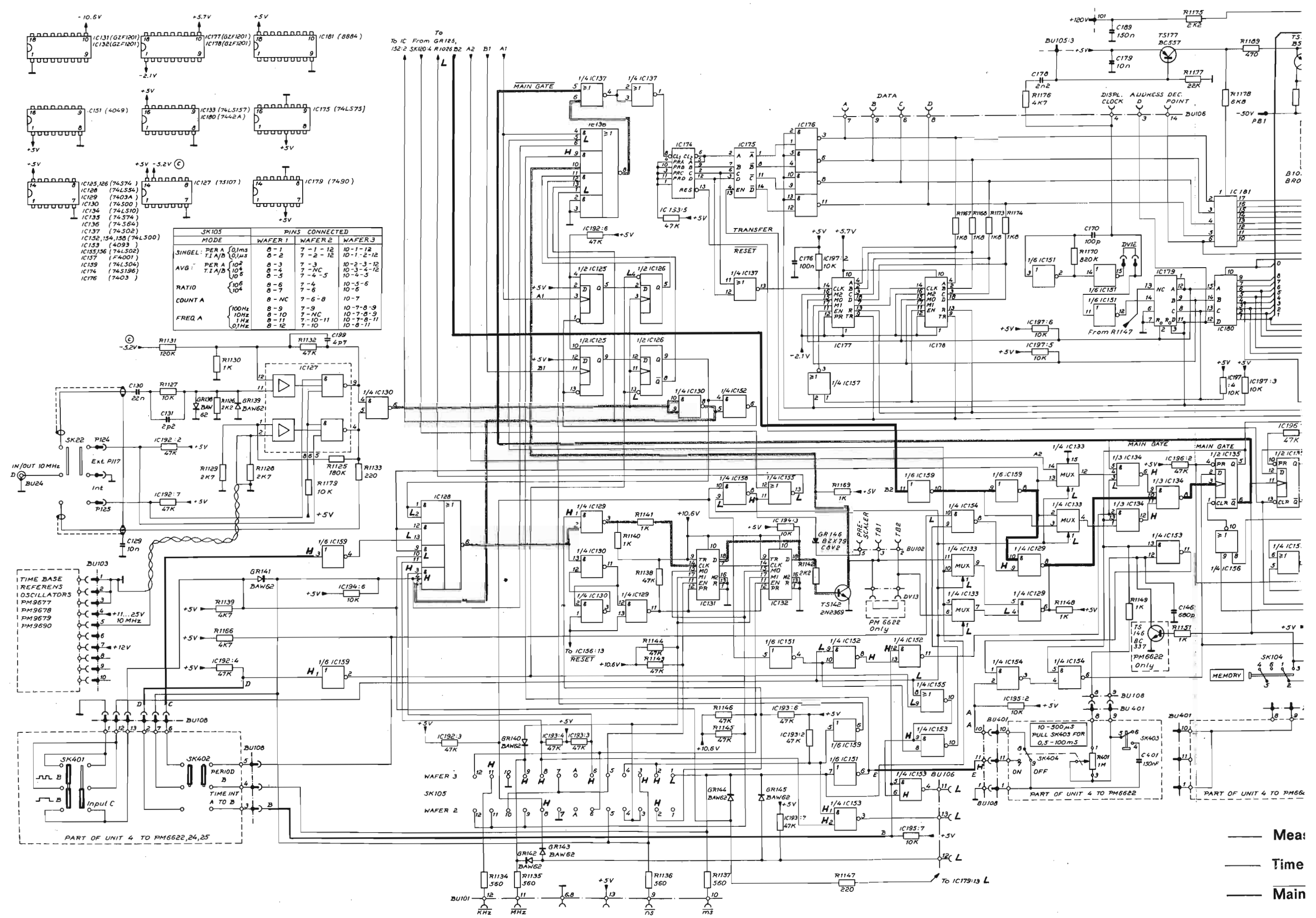

MODE	PINS CONNECTED		
	WAFER 1	WAFER 2	WAFER 3
SINGEL PER A T.I.A/D	0-1	7-1-12	10-1-12
	0-2	7-2-12	10-1-2-12
AVG PER A T.I.A/D	0-3	7-3	10-3-3-12
	0-4	7-NC	10-3-4-12
RATIO 10 <sup>6</sup> / <sub>10<sup>4</sup></sub>	0-5	7-4-5	10-4-5
	0-6	7-4	10-5-6
COUNT A	0-7	7-6	10-6
	0-NC	7-6-8	10-7
FREQ A	0-8	7-8	10-7-8-9
	0-10	7-NC	10-7-8-9
	0-11	7-10-11	10-7-8-11
	0-12	7-10	10-8-11

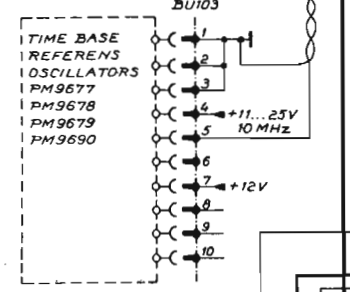

To IC From GR125, 152-2 SK100-4 R1026 D2 A2 B1 A1

Mea:  
Time  
Main







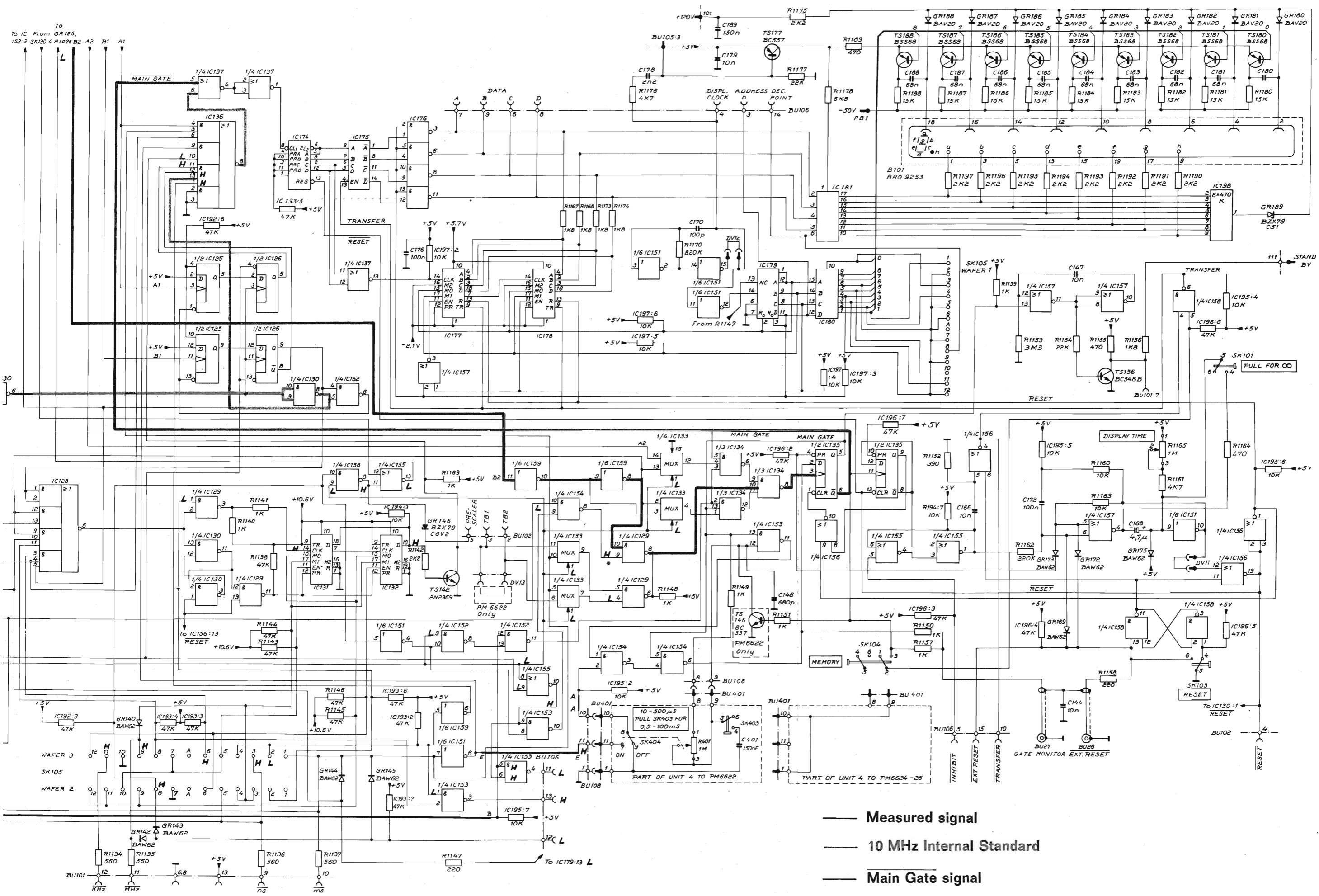

— Measured signal  
- - - 10 MHz Internal Standard  
... Main Gate signal

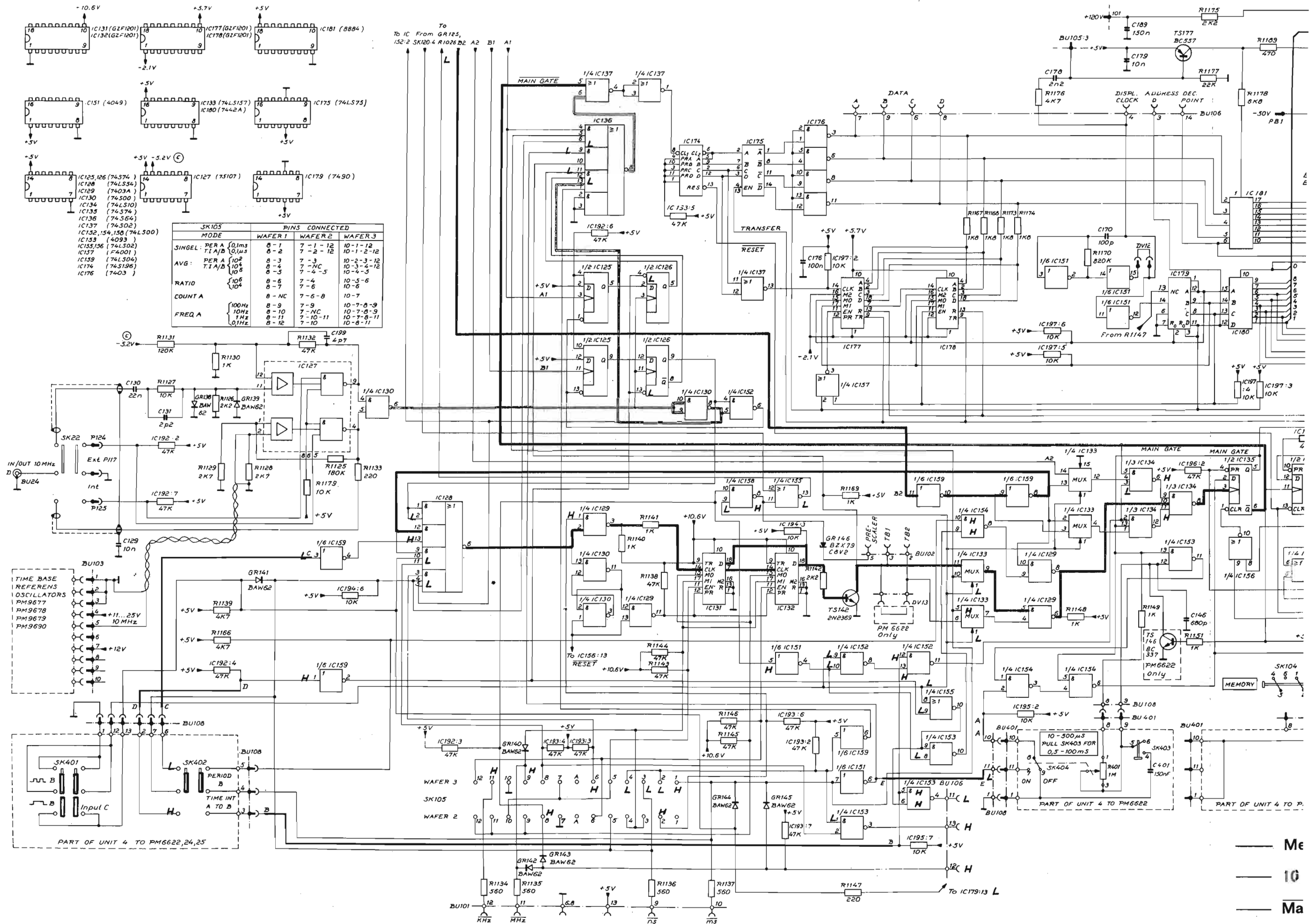

MODE	PINS CONNECTED			
	WAFER 1	WAFER 2	WAFER 3	
SINGEL PER A	0.1ms	8-1	7-1-12	10-1-12
	0.1ms	8-2	7-2-12	10-1-2-12
AVG: PER A	10 <sup>2</sup>	8-3	7-3	10-2-3-12
	10 <sup>4</sup>	8-4	7-NC	10-3-4-12
	10 <sup>6</sup>	8-5	7-4-5	10-4-5
RATIO	10 <sup>6</sup>	8-6	7-4	10-5-6
	10 <sup>4</sup>	8-7	7-6	10-6
COUNT A	NC	8-NC	7-6-8	10-7
	100Hz	8-9	7-9	10-7-8-9
FREQ A	10Hz	8-10	7-NC	10-7-8-9
	1Hz	8-11	7-10-11	10-7-8-11
	0.1Hz	8-12	7-10	10-8-11

Me  
10  
Ma

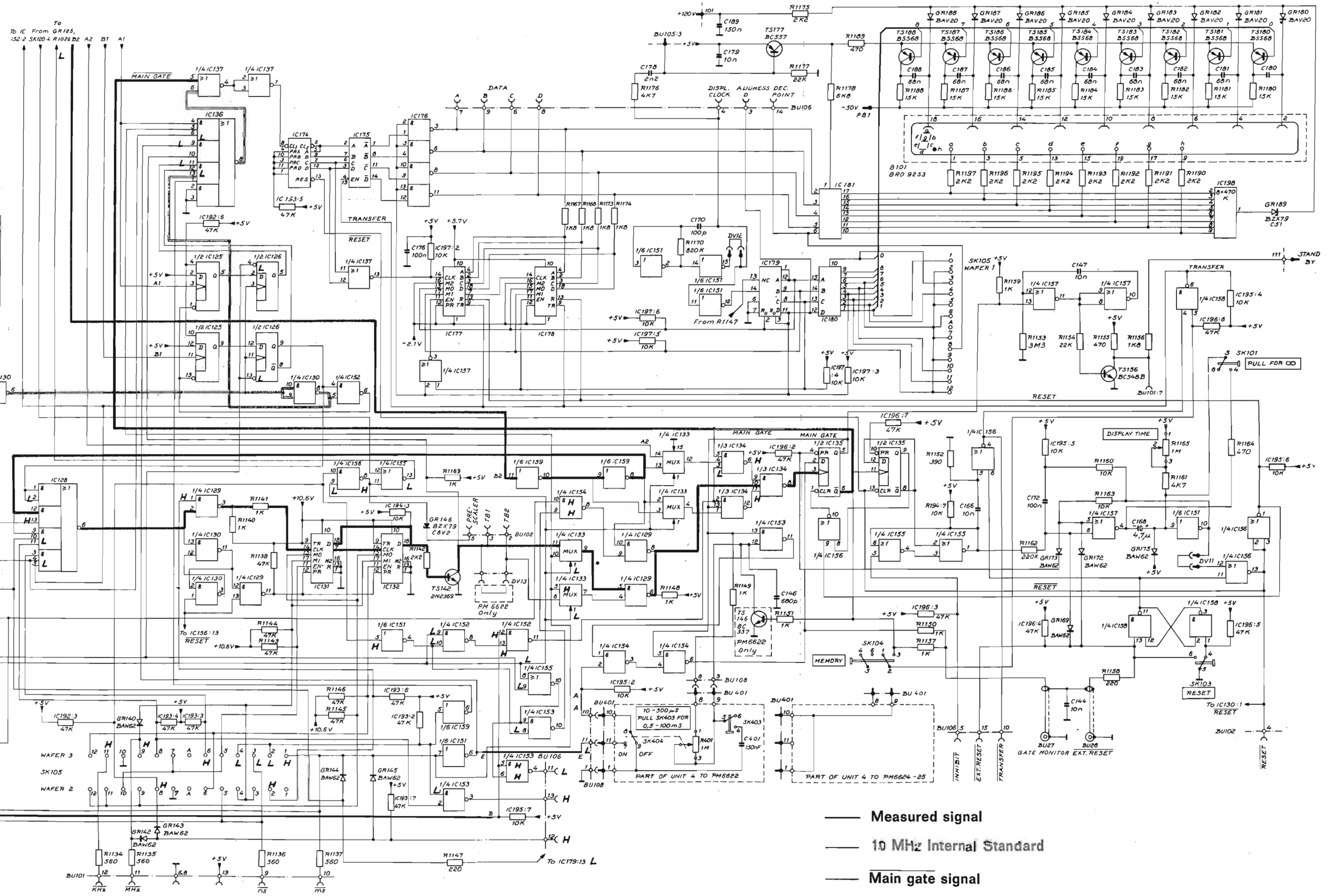

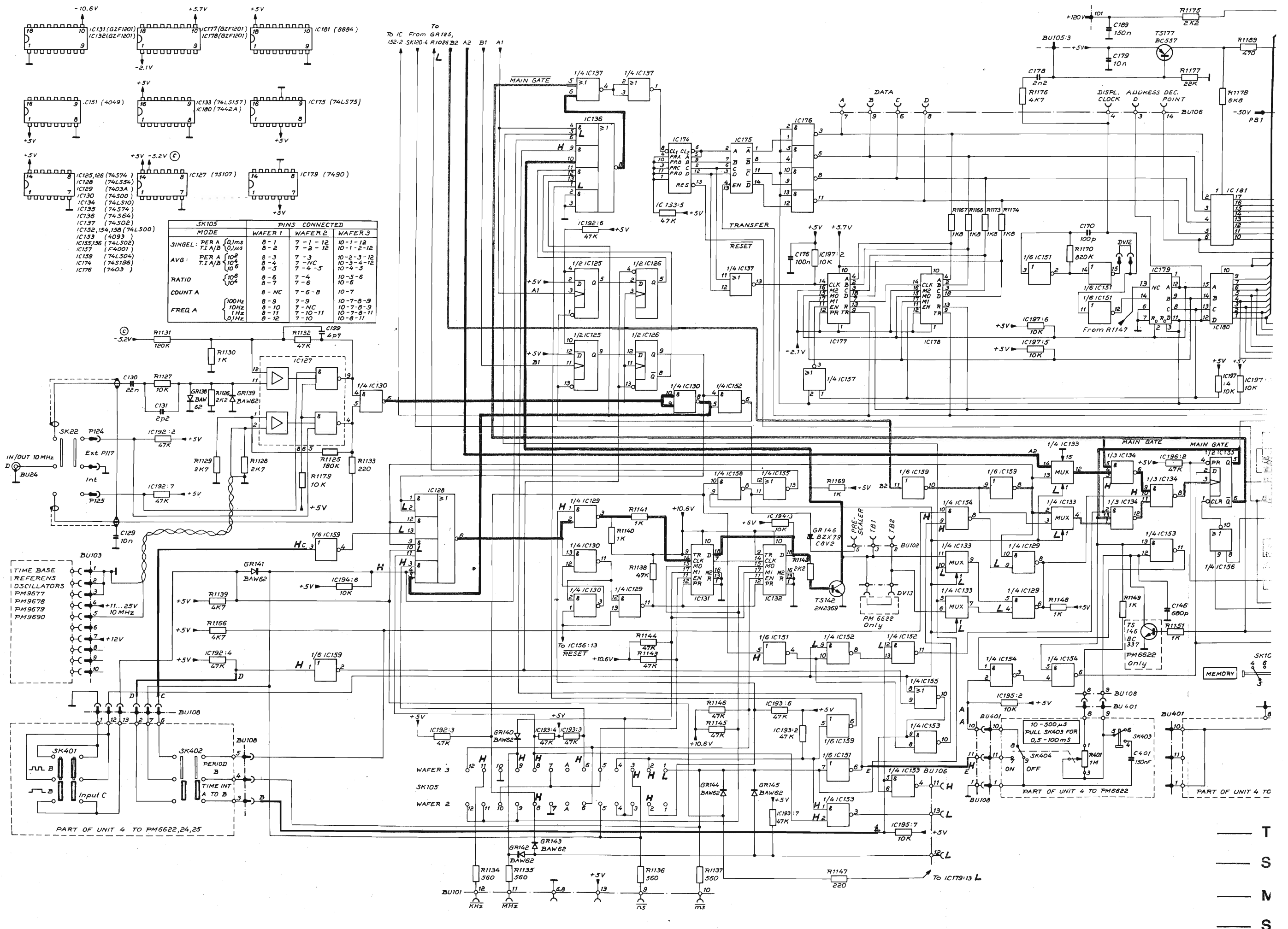

MODE	PINS CONNECTED		
	WAFER 1	WAFER 2	WAFER 3
SINGEL: PER A (0.1ms)	8-1	7-1-12	10-1-12
T.I.A/B (0.1ms)	8-2	7-2-12	10-1-2-12
AVG: PER A (10 <sup>2</sup> )	8-3	7-3	10-2-3-12
T.I.A/B (10 <sup>2</sup> )	8-4	7-NC	10-3-4-12
10 <sup>6</sup>	8-5	7-4-5	10-4-5
RATIO 10 <sup>6</sup>	8-6	7-4	10-5-6
10 <sup>4</sup>	8-7	7-6	10-6
COUNT A	8-NC	7-6-8	10-7
FREQ A 100Hz	8-9	7-9	10-7-8-9
10Hz	8-10	7-NC	10-7-8-9
1Hz	8-11	7-10-11	10-7-8-11
0.1Hz	8-12	7-10	10-8-11

TIME BASE REFERENS OSCILLATORS  
 PM9677  
 PM9678  
 PM9679  
 PM9690

PART OF UNIT 4 TO PM6622,24,25

10-500μS PULL SK403 FOR 0.5-100ms  
 PART OF UNIT 4 TO PM6622

PART OF UNIT 4 TO

T  
 S  
 N  
 S





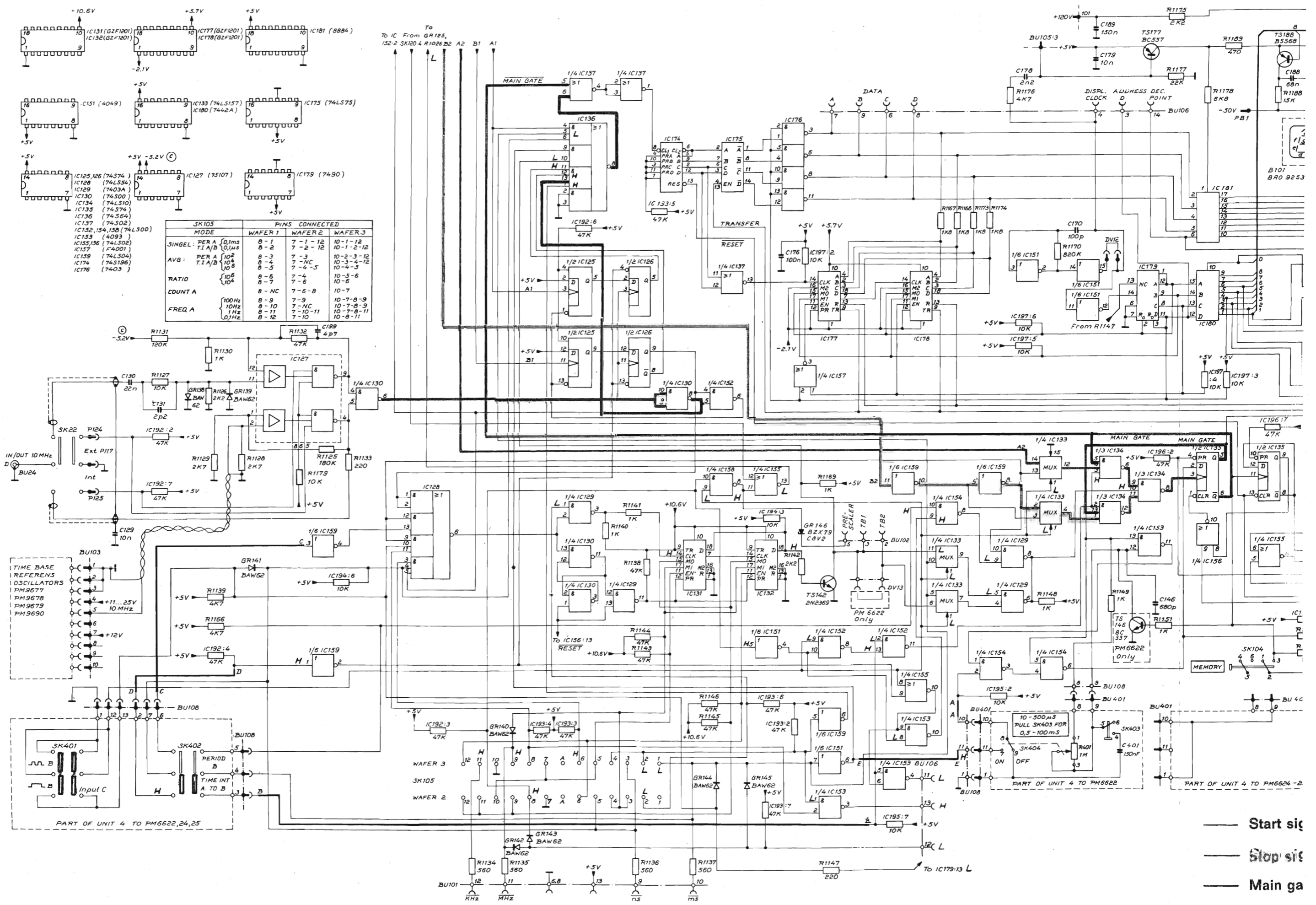

SK105		PINS CONNECTED		
MODE	WAFER 1	WAFER 2	WAFER 3	
SINGEL: PER A	0-1	7-1-12	10-1-12	
	T.I.A/B	0-2	7-2-12	10-1-2-12
AVG: PER A	0-3	7-3	10-2-3-12	
	0-4	7-NC	10-3-4-12	
	T.I.A/B	0-5	7-4-5	10-4-5
RATIO	0-6	7-4	10-5-6	
	0-7	7-6	10-6	
COUNT A	0-NC	7-6-8	10-7	
	0-9	7-9	10-7-8-9	
	10Hz	7-NC	10-7-8-9	
FREQ A	0-10	7-10-11	10-7-8-11	
	1Hz	7-10	10-8-11	
	0.1Hz	8-12	10-8-11	

TIME BASE REFERENCE OSCILLATORS  
 PM9677  
 PM9678  
 PM9679  
 PM9690

PART OF UNIT 4 TO PM6622,24,25

10-500μs PULL SK403 FOR 0.5-100ms

PART OF UNIT 4 TO PM6624-26

- Start sig
- Stop sig
- Main ga
- 10 MHz





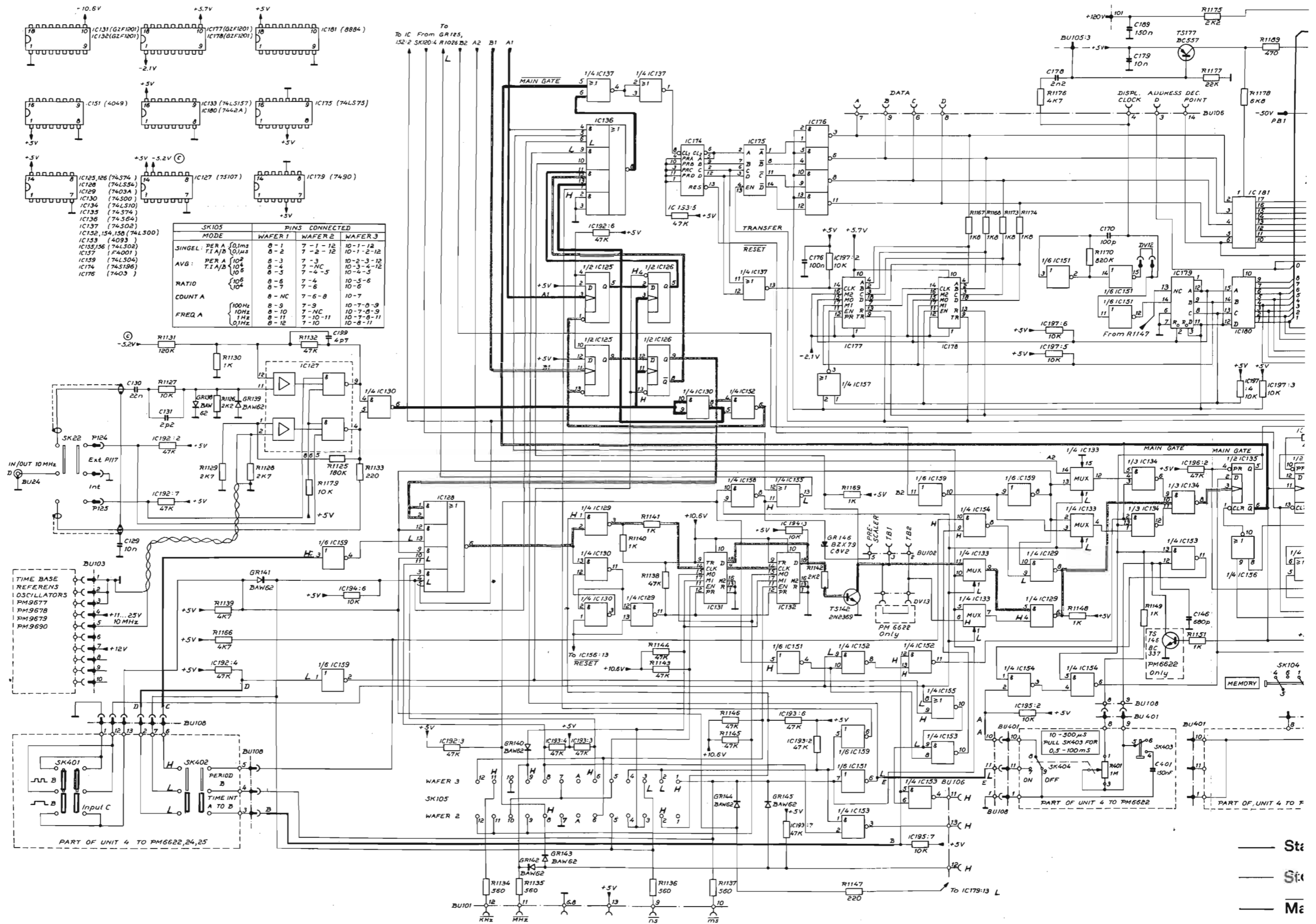

MODE	PINS CONNECTED		
	WAFER 1	WAFER 2	WAFER 3
SINGEL: PER A (0.1ms)	8-1	7-1-12	10-1-12
	8-2	7-2-12	10-2-12
T.T.A/D (0.1ms)	8-3	7-3	10-3-12
	8-4	7-4	10-4-12
AVG: PER A (10 <sup>2</sup> )	8-5	7-5	10-5-12
	8-6	7-6	10-6-12
T.T.A/D (10 <sup>2</sup> )	8-7	7-7	10-7-12
	8-8	7-8	10-8-12
RATIO (10 <sup>6</sup> / <sub>10<sup>4</sup></sub> )	8-9	7-9	10-9-12
	8-10	7-10	10-10-12
COUNT A	8-11	7-11	10-11-12
	8-12	7-12	10-12-12
FREQ A (100Hz)	8-13	7-13	10-13-12
	8-14	7-14	10-14-12
(10Hz)	8-15	7-15	10-15-12
	8-16	7-16	10-16-12
(1MHz)	8-17	7-17	10-17-12
	8-18	7-18	10-18-12

Sta  
St  
Ma  
10

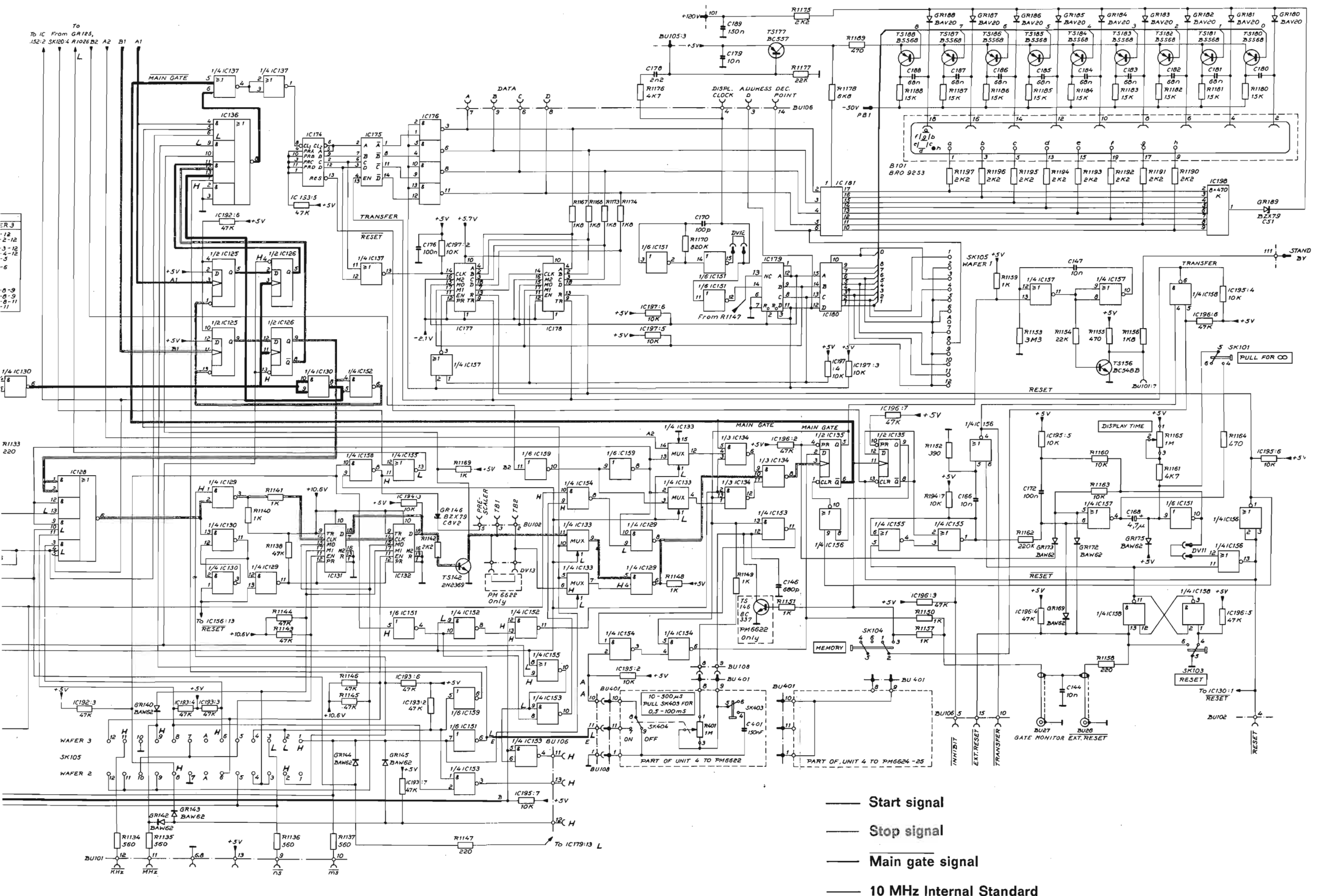

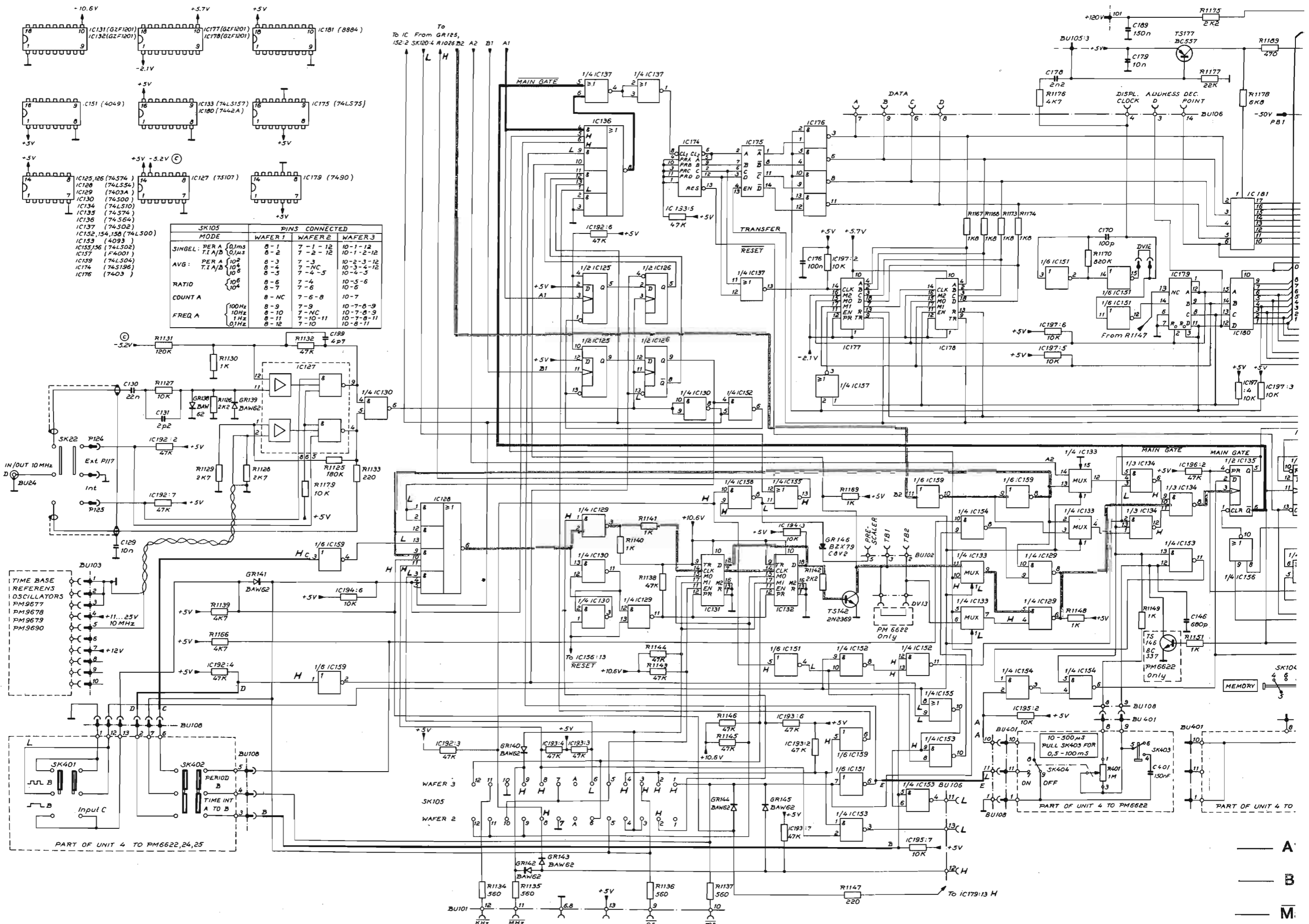

MODE	PINS CONNECTED		
	WAFER 1	WAFER 2	WAFER 3
SINGEL: PER A (0.1ms)	8-1	7-1-12	10-1-12
T.I.A/B (0.1ms)	8-2	7-2-12	10-1-2-12
AVG: PER A (10 <sup>-2</sup> )	8-3	7-3	10-2-3-12
T.I.A/B (10 <sup>-2</sup> )	8-4	7-NC	10-3-4-12
(10 <sup>-6</sup> )	8-5	7-4-5	10-4-5
RATIO (10 <sup>-6</sup> )	8-6	7-4	10-5-6
(10 <sup>-4</sup> )	8-7	7-6	10-6
COUNT A	8-NC	7-6-8	10-7
FREQ A (100Hz)	8-9	7-9	10-7-8-9
(10Hz)	8-10	7-NC	10-7-8-9
(1Hz)	8-11	7-10-11	10-7-8-11
(0.1Hz)	8-12	7-10	10-8-11

- TIME BASE REFERENC OSCILLATORS
- PM9677
- PM9678
- PM9679
- PM9690

PART OF UNIT 4 TO PM6622, 24, 25

PART OF UNIT 4 TO PM6622

PART OF UNIT 4 TO

A  
B  
M

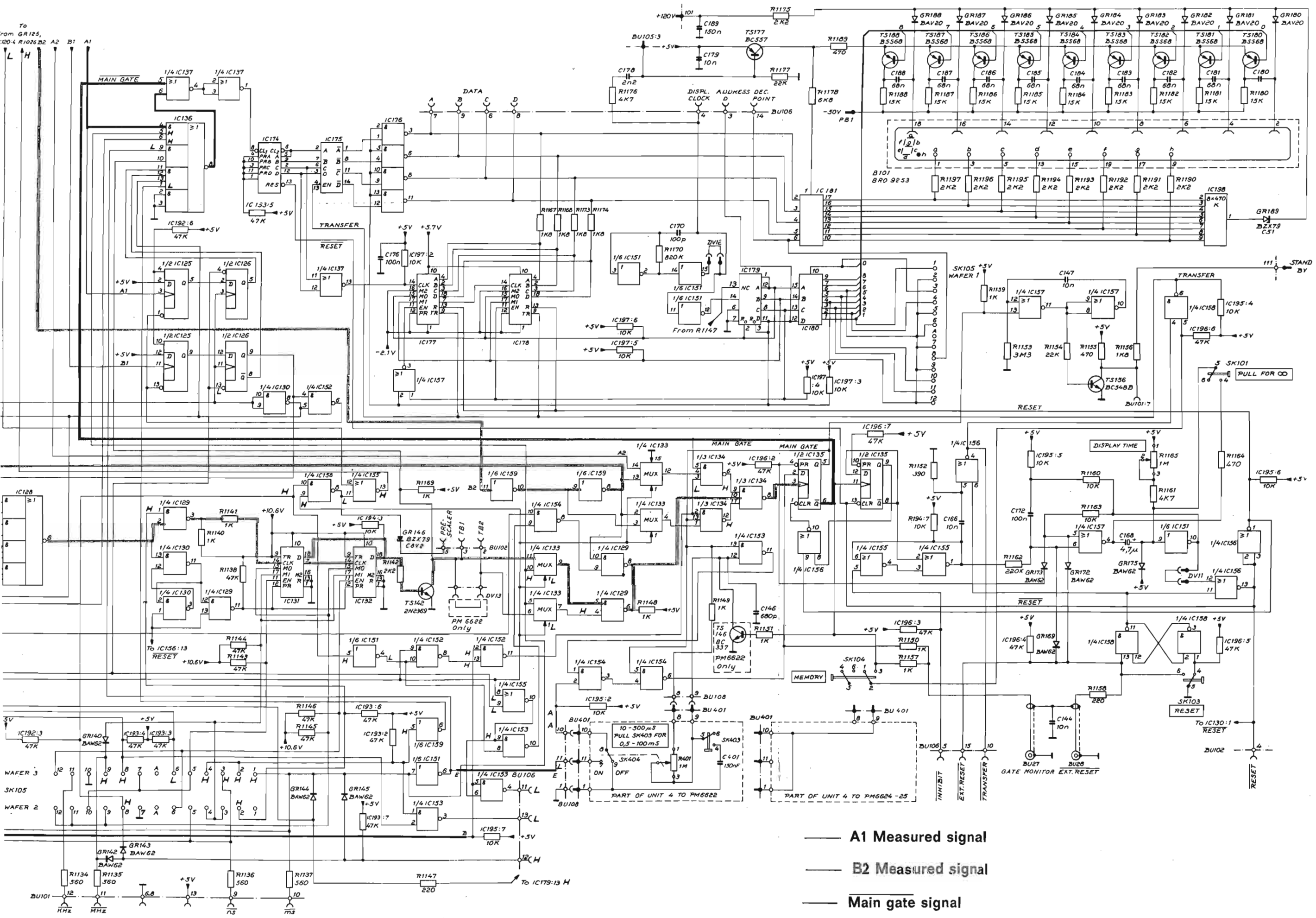

- A1 Measured signal
- - - B2 Measured signal
- ... Main gate signal

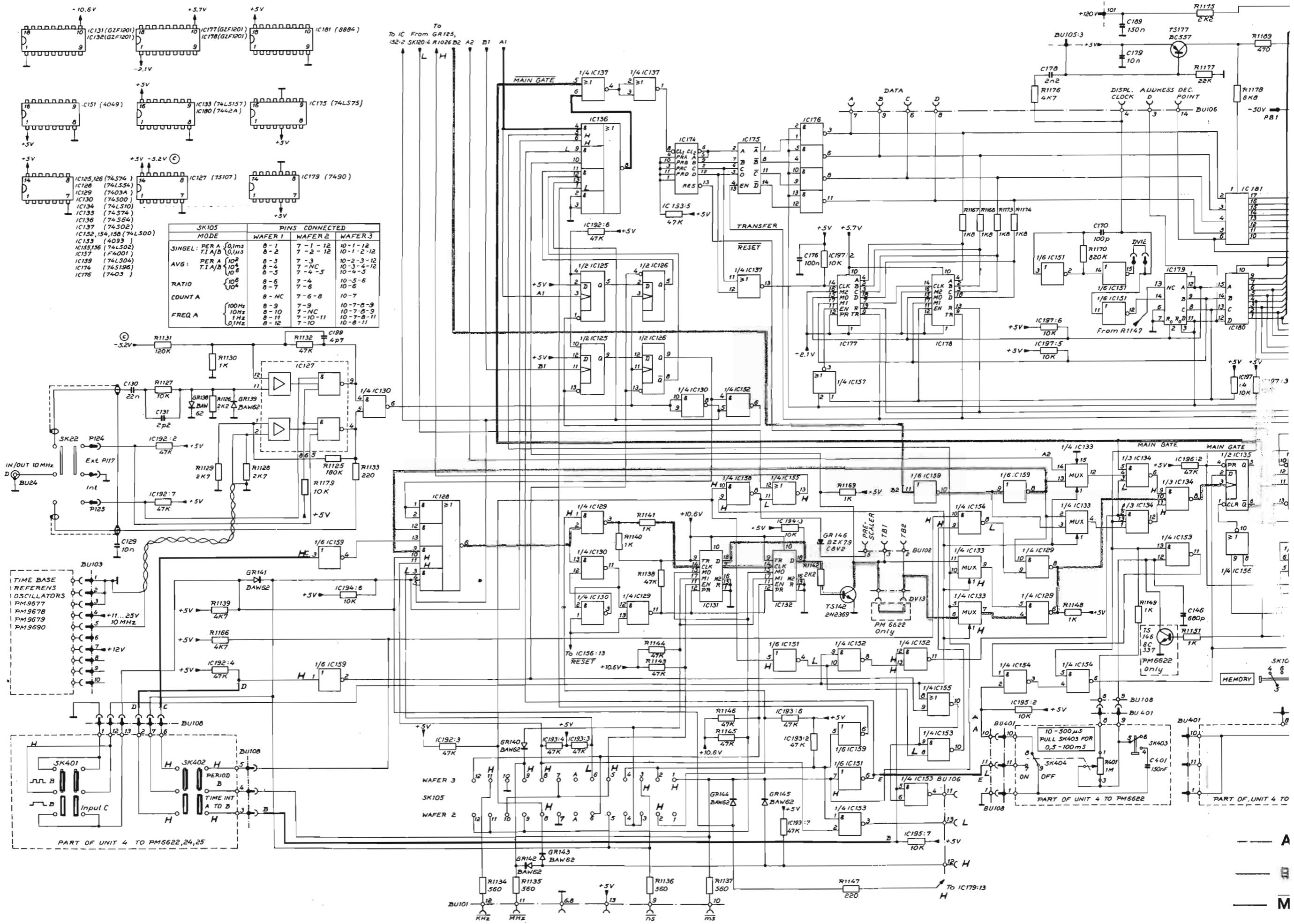

SK105 MODE	PINS CONNECTED		
	WAFER 1	WAFER 2	WAFER 3
SINGEL: PER A 0.1ms	8-1	7-1-12	10-1-12
TI A/B 0.1ms	8-2	7-2-12	10-1-2-12
AVG: PER A 10 <sup>2</sup>	8-3	7-3	10-2-3-12
TI A/B 10 <sup>4</sup>	8-4	7-NC	10-3-4-12
10 <sup>6</sup>	8-5	7-4-5	10-4-5
RATIO 10 <sup>8</sup>	8-6	7-4	10-5-6
10 <sup>4</sup>	8-7	7-6	10-6
COUNT A	8-NC	7-6-8	10-7
FREQ A 100Hz	8-9	7-9	10-7-8-9
10Hz	8-10	7-NC	10-7-8-9
1Hz	8-11	7-10-11	10-7-8-11
0.1Hz	8-12	7-10	10-8-11

TIME BASE REFERENS OSCILLATORS  
 PM9677  
 PM9678  
 PM9679  
 PM9690

PART OF UNIT 4 TO PM662, 24, 25

10-500μS  
 FULL SK403 FOR  
 0.5-100mS

PART OF UNIT 4 TO PM662

A  
 B  
 M

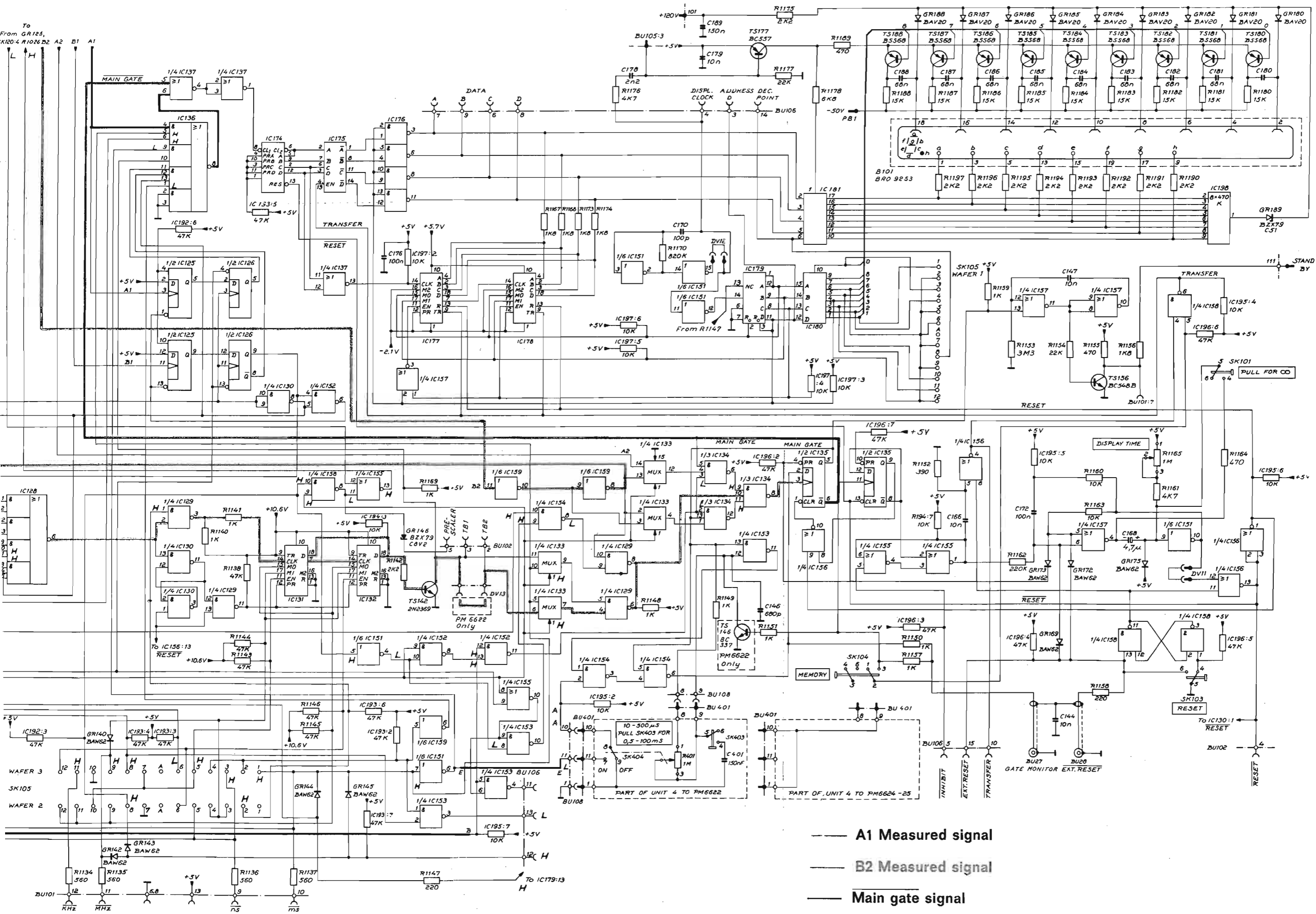

- - - A1 Measured signal  
 - - - B2 Measured signal  
 - - - Main gate signal





# Count A Start/Stop by B

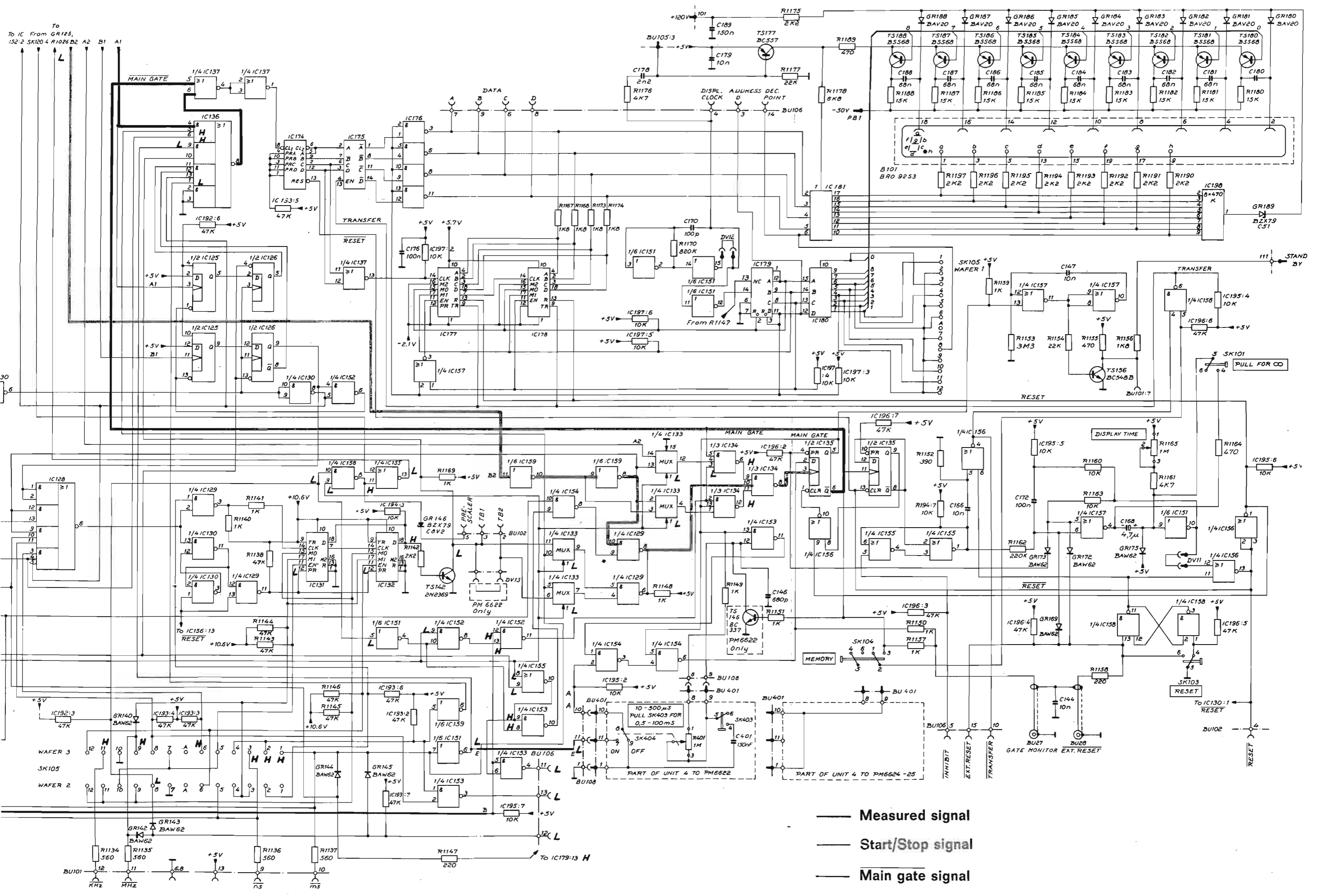

- Measured signal
- - - Start/Stop signal
- Main gate signal



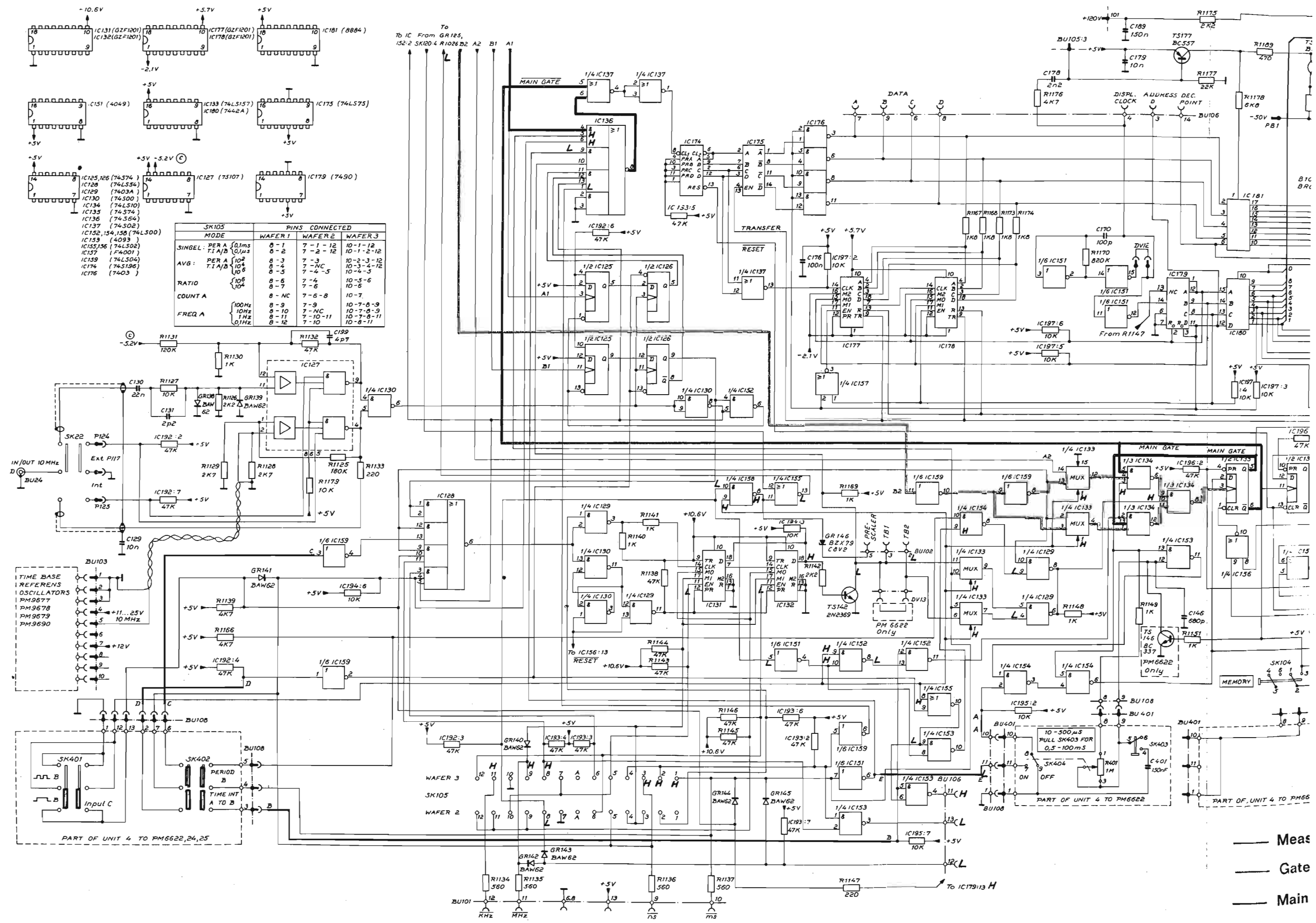

MODE	PINS CONNECTED		
	WAFER 1	WAFER 2	WAFER 3
SINGEL: PER A (0.1ms)	8-1	7-1-12	10-1-12
T.I.A/B (0.1ms)	8-2	7-2-12	10-1-2-12
AVG: PER A (10 <sup>2</sup> )	8-3	7-3	10-2-3-12
T.I.A/B (10 <sup>4</sup> )	8-4	7-NC	10-3-4-12
(10 <sup>6</sup> )	8-5	7-4-5	10-4-5
RATIO (10 <sup>8</sup> )	8-6	7-4	10-5-6
(10 <sup>4</sup> )	8-7	7-6	10-6
COUNT A (100Hz)	8-NC	7-6-8	10-7
(10Hz)	8-9	7-9	10-7-8-9
(1Hz)	8-10	7-NC	10-7-8-9
(0.1Hz)	8-12	7-10-11	10-8-11

— Meas  
 — Gate  
 — Main



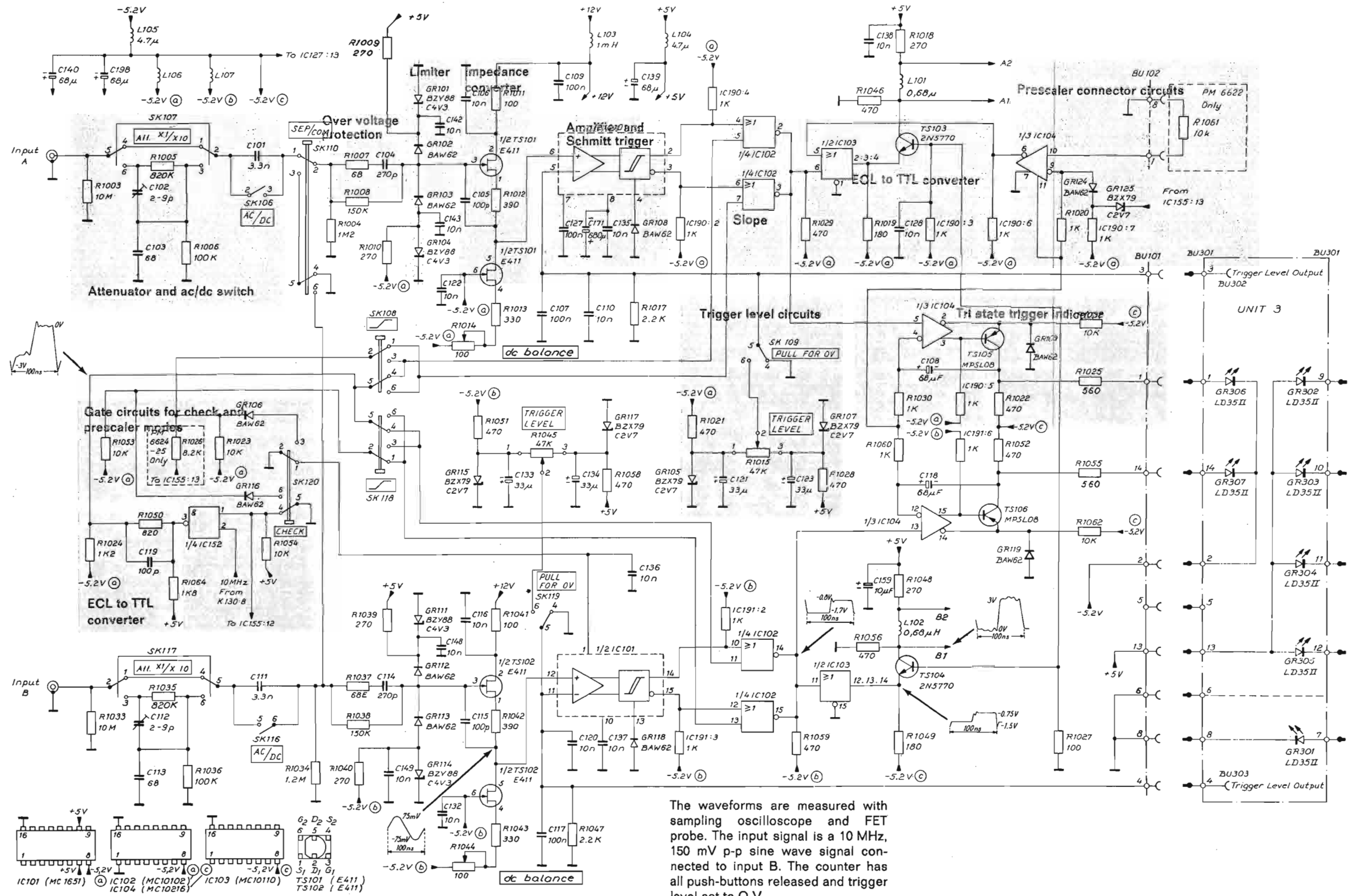

The waveforms are measured with sampling oscilloscope and FET probe. The input signal is a 10 MHz, 150 mV p-p sine wave signal connected to input B. The counter has all push-buttons released and trigger level set to 0 V.